

TECHNICAL MANUAL

**OPERATORS, UNIT, DIRECT SUPPORT AND
GENERAL SUPPORT MAINTENANCE MANUAL**

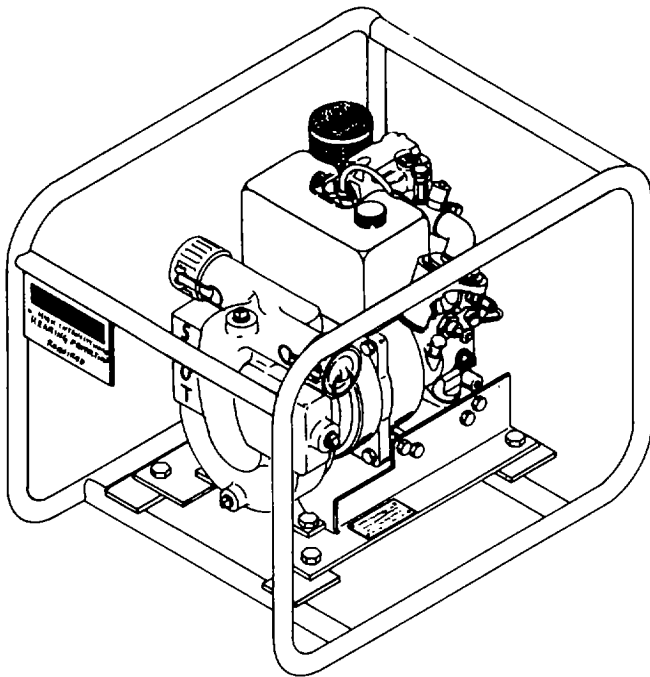

**PUMP UNIT, FLAMMABLE LIQUID
CENTRIFUGAL SELF-PRIMING,
2-INCH, 100 GPM DIESEL
ENGINE DRIVEN
NSN 4320-01-263-3604**

INTRODUCTION	1-1
OPERATING INSTRUCTIONS	2-1
OPERATOR'S MAINTENANCE INSTRUCTIONS	3-1
UNIT MAINTENANCE INSTRUCTIONS	4-1
DIRECT SUPPORT MAINTENANCE INSTRUCTIONS	5-1
GENERAL SUPPORT MAINTENANCE INSTRUCTIONS	6-1
MAINTENANCE ALLOCATION CHART	B-1
ILLUSTRATED LIST OF MANUFACTURED ITEMS	F-1
GLOSSARY	
ALPHABETICAL INDEX	

Approved for public release; distribution is unlimited.

CHANGE
NO. 1

HEADQUARTERS
DEPARTMENT OF THE ARMY
WASHINGTON, D. C. , 9 NOVEMBER 1992

Operator's, Unit, Direct Support and General Support
Maintenance Manual

PUMP UNIT, FLAMMABLE LIQUID
CENTRIFUGAL SELF-PRIMING,
2-INCH, 100 GPM,
DIESEL ENGINE DRIVEN
NSN 4320-01-307-0538

Approved for public release; Distribution is unlimited

TM 10-4320-310-14, 22 August 1991 is changed as follows:

1. Title is changed as shown above.
2. Remove and insert pages as indicated below. New or changed text material is indicated by a vertical bar in the margin. An illustration change is indicated by a miniature pointing hand.

Remove pages

i and ii
C-1 and C-2

Insert pages

i and ii
C-1 and C-2

3. Retain this sheet in front of manual for reference purposes.

By Order of the Secretary of the Army:

GORDON R. SULLIVAN
General, United States Army
Chief of Staff

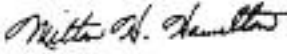
Official: 
MILTON H. HAMILTON
Administrative Assistant to the
Secretary of the Army
03018

DISTRIBUTION:

To be distributed in accordance with DA Form 1 2-25-E, block no. 5471, requirements for TM 10-4320-310-14.

WARNING

SERIOUS INJURY

may result if the engine is not turned off during service or maintenance.

DEATH OR SERIOUS INJURY

to personnel or damage to unit could occur if engine lifting strap is used to lift the centrifugal pump unit. The lifting strap shall be used to lift only the engine.

DEATH OR SERIOUS INJURY

could occur if fuel is not handled carefully. Use in a well-ventilated area away from open flame, arcing equipment, ignition sources, heaters, or excessive heat. Engine must be turned off and cool before refueling. Use proper refueling procedures and equipment to avoid spillage. Do not run engine near open fuel containers. Always store fuel in properly marked containers. DO NOT SMOKE.

SEVERE BURNS

Muffler and related components get hot enough during pump operation to cause severe burns. Avoid contact with muffler and related components during checks describe in this text.

CARBON MONOXIDE (EXHAUST GAS) CAN KILL YOU

Exposure to exhaust gases produces symptoms of headache, dizziness, loss of muscular control, drowsiness, or coma. Brain damage or death can result from severe exposure.

Fumes from engine become concentrated with poor ventilation. Operate engine in a ventilated area only.

While running engine, be alert for fumes. Keep area ventilated. If someone is overcome, expose to fresh air; keep warm and still; give artificial respiration if needed. Seek medical attention. Administer oxygen, if available.

SERIOUS INJURY

Before starting the engine and after making repairs or adjustments on the fuel system, a 17 mm wrench must be available to allow rapid removal of the steel fuel line at the injection pump in case of a runaway condition. Failure to heed this warning can result in injury to personnel and equipment damage.

WARNING

DEATH OR SERIOUS INJURY

could occur if compressed air is directed against the skin. Do not use compressed air for cleaning or drying unless the pressure is/has been reduced to 30 psi (2.06 bar) or less. When working with compressed air always use chip guards, eye protection, and other personal equipment.

DEATH OR SERIOUS INJURY

could occur if unauthorized or unnecessary personnel are in the hoisting area. Permit only personnel actually engaged in the hoisting operation to be near the unit and hoisting equipment. All instructions for the hoisting operations must come from one authorized person.

DEATH OR SERIOUS INJURY

or damage to unit could occur from improper hoisting. Hoist the load slowly to avoid tearing out lifting strap, slipping slings, or load shift. Do not jerk the load or swing it from side to side-to-side when hoisting. This places additional stress on hoisting components which can cause failure and loss of load. Be sure hoisting equipment is on solid footing and is suitable for the size of the load. Watch boom angle and overhead clearance when hoisting.

HEALTH AND SAFETY HAZARD

Dry cleaning solvent P-D-680 (safety or Stoddard's Solvent) is potentially dangerous. Avoid repeated and prolonged breathing of vapors and skin contact with the liquid. Do not use near open flame, arcing equipment, or other ignition sources. Always wear eye protection and protective clothing. The flash point of P-D-680 is 100°F to 138°F (38°C to 59°C).

SERIOUS INJURY

could result from injector fuel spray. Keep hands away from fuel spray.

SERIOUS BURNS

could result from handling heated parts. Use proper equipment to handle heated parts.

LIVE STEAM

used for cleaning shall not exceed 100 psi (6.9 bar). Use goggles or face shield for eye protection. Do not direct live steam against skin.

**Operator's, Unit, Direct Support
and General Support Maintenance Manual**

for

**PUMP UNIT, FLAMMABLE LIQUID, CENTRIFUGAL,
SELF-PRIMING, 2 INCH, 100 GPM, DIESEL ENGINE DRIVEN
NSN 4320-01-307-0538**

Approved for public release; distribution is unlimited.

REPORTING ERRORS AND RECOMMENDING IMPROVEMENTS

You can help to improve this manual. If you find any mistakes, or if you know of a way to improve the procedures, please let us know. Mail your letter, DA form 2028 (Recommended Changes to Publications and Blank Forms), or DA Form 2028-2 located in the back of this manual direct to: Commander, U. S. Army Troop Support Command, ATTN: AMSTR-MMTS, 4300 Goodfellow Boulevard, St. Louis, MO 63120- 1798. A reply will be furnished directly to you.

TABLE OF CONTENTS

			Page
CHAPTER	1	INTRODUCTION	1-1
	Section I	General Information.....	1-1
	Section II	Equipment Description.....	1-2
	Section III	Technical Principles of Operation	1-6
CHAPTER	2	OPERATING INSTRUCTIONS	2-1
	Section I	Description and Use of Operator's Controls and Indicators.....	2-1
	Section II	Operator's Preventive Maintenance Checks and Services (PMCS).....	2-3
	Section III	Operation Under Usual Conditions	2-23
	Section IV	Operation Under Unusual Conditions	2-30
CHAPTER	3	OPERATOR MAINTENANCE INSTRUCTIONS	3-1
	Section I	Lubrication Instructions	3-1
	Section II	Troubleshooting Procedures	3-2
	Section III	Maintenance Procedures	3-8
CHAPTER	4	UNIT MAINTENANCE INSTRUCTIONS	4-1
	Section I	Repair Parts, Special Tools, TMDE, and Support Equipment.....	4-1
	Section II	Service Upon Receipt of Equipment	4-1
	Section III	Preventive Maintenance Checks and Services	4-5
	Section IV	Troubleshooting	4-7
	Section V	Maintenance Procedures	4-10
	Section VI	Preparation for Storage or Shipment	4-37

CHAPTER 5	DIRECT SUPPORT MAINTENANCE INSTRUCTIONS	5-1
Section I	Troubleshooting	5-1
Section II	Maintenance Procedures	5-3
CHAPTER 6	GENERAL SUPPORT MAINTENANCE INSTRUCTIONS	6-1
Section I	Troubleshooting	6-1
Section II	Maintenance Procedures	6-1
APPENDIX A	REFERENCES	A-1
APPENDIX B	MAINTENANCE ALLOCATION CHART	B-1
APPENDIX C	COMPONENTS OF END ITEM AND BASIC ISSUE ITEMS LISTS	C-1
APPENDIX D	ADDITIONAL AUTHORIZATION LIST	D-1
APPENDIX E	EXPENDABLE/DURABLE SUPPLIES AND MATERIALS LISTS	E-1
APPENDIX F	ILLUSTRATED LIST OF MANUFACTURED ITEMS	F-1
	GLOSSARY	GLOSSARY 1
	ALPHABETICAL INDEX	INDEX 1

HOW TO USE THIS MANUAL

Be sure to read all Warnings before using your equipment

This manual contains operating instructions for the Operator, Unit and Direct Support and General Support Maintenance instructions for the Diesel Engine Driven, 100 GPM, 2 Inch, Self-Priming, Centrifugal Flammable Liquid, 88D SPEC3199K6 Pump Unit. Becoming familiar with this manual will enable you to operate and maintain the equipment in good working order.

- t** Chapter 1 - Introduces you to the equipment and gives you information such as weight, height, length, a reference for generally used abbreviations, cross reference information and principles of operation. This chapter is incorporates a full page illustration of the equipment.
- t** Chapter 2 - Provides information necessary to identify and use the equipment's operating controls. Operating procedures tell you how to use the equipment in both usual and unusual weather conditions. In addition, preventive maintenance instructions provide information needed to inspect and service the centrifugal pump unit.
- t** Chapter 3 - Provides operator lubrication and maintenance instructions for troubleshooting the equipment malfunctions.
- t** Chapter 4 - Provides unit maintenance instructions including service upon receipt, preventive maintenance and troubleshooting information, detailed maintenance and repair procedures for the Unit Maintenance repairer, and storage and shipment instructions.
- t** Chapter 5 - Provides detailed component repair instructions for the Direct Support maintenance group.
- t** Chapter 6 - Provides detailed component repair instructions for the General Support maintenance group.
- t** Appendix A gives you a list of frequently used forms and publications.
- t** Appendix B is the Maintenance Allocation Chart (MAC).
- t** Appendix C describes components that make up the end item and are shipped with the basic equipment. It also lists components that are not mounted on the centrifugal pump unit but are required to make the unit functional. Components in the Components of End Item and Basic Issue Items Lists are illustrated for easy identification.
- t** Appendix D lists additional equipment authorized for your unit for use with, but are not supplied with the centrifugal pump unit.
- t** Appendix E provides you with information about expendable supplies such as sealants, paints, lubricants, etc. required during operation or maintenance of the centrifugal pump unit.

CHAPTER 1

INTRODUCTION

Section I. GENERAL INFORMATION

1-1. SCOPE

Type of Manual: Operator's, Unit, Direct Support and General Support Maintenance

Model Number and Equipment Name: 88D SPEC3199K6 Pump Unit, Flammable Liquid, Centrifugal, Self-Priming, 2 Inch, 100 GPM, Diesel Engine Driven

Purpose of Equipment: Pumps Flammable Liquid

1-2. MAINTENANCE FORMS, RECORDS, AND REPORTS

Department of the Army forms and procedures used for equipment maintenance will be those prescribed by DA PAM 738-750, The Army Maintenance Management System (TAMMS).

1-3. REPORTING EQUIPMENT IMPROVEMENT RECOMMENDATIONS (EIR'S)

If your centrifugal pump unit needs improvement, let us know. Send us an EIR. You, the user, are the only one who can tell us what you don't like about your equipment. Let us know why you don't like the design or performance. Put it on an SF 368 (Quality Deficiency Report). Mail it to us at U. S. Army Troop Support Command, ATTN: AMSTR-MOF, 4300 Goodfellow Boulevard, St. Louis, MO 63120-1798. We'll send you a reply.

1-4. LIMITED WARRANTY

a. The centrifugal pump unit is warranted by Scot Pump Division of Ardox Corporation against defective workmanship and materials for 12 months from the date of manufacture. The installation date may be found in block 23, DA form 2408-9. The date manufactured appears on the identification plate.

b. Report all defects in material or workmanship to your supervisor who will take appropriate action through your unit maintenance shop.

c. Scot Pump Division of Ardox Corporation limits its obligation under this warranty to furnishing or replacing any product to be defective as a result of workmanship or materials. They reserve the right to have the defective product returned at the expense of the user in order to establish the claim. If the responsibility for the failure is that of Scot Pump Division of Ardox Corporation they will absorb the transportation charges. The costs of labor, such as for removal and reinstallation of the product, are not covered under this warranty.

d. Scot Pump Division of Ardox Corporation does not guarantee to maintain this product in working order when its capacity is too small for the requirements, or where the unit is subject to extraordinary use.

e. Scot Pump Division of Ardox Corporation assumes no liability for incidental and consequential damages which may result from the use or misuse of its products. Some states do not allow the exclusion or limitation of incidental or consequential damages, however, so this limitation or exclusion may not apply.

f. This warranty provides specific legal rights, and you may also have other rights which vary from state to state.

1-5. DESTRUCTION OF ARMY MATERIAL TO PREVENT ENEMY USE



Demolition of the centrifugal pump unit will not be attempted , except upon receipt of orders from proper authority.

a. General. Methods of destruction should achieve such damage to equipment and repair parts that it will not be possible to restore the equipment to usable condition in the combat zone either by repair or cannibalization.

(1) Mechanical Destruction. Using an ax, pick, sledge hammer, or any heavy implement, damage the engine and pump.

(2) Destruction by Explosives. Place as many charges as time permits in vital areas such as under engine and pump or any other place that will assure complete destruction of the centrifugal pump unit. Use a suitable detonator to detonate all charges simultaneously.

b. Additional information. For additional information on procedures for destruction of equipment to prevent enemy use, refer to TM 750-244-3.

1-6. PREPARATION FOR STORAGE OR SHIPMENT

Contact organizational maintenance for centrifugal pump unit preparation for storage and shipment (paragraph 423).

1-7. NOMENCLATURE CROSS-REFERENCE

For precise identification, simplified nomenclature has been established for clarity and is shown in the nomenclature cross-reference list

NOMENCLATURE CROSS-REFERENCE LIST

<u>Common Name</u>	<u>Official Nomenclature</u>
Centrifugal Pump Unit Engine Driven Engine Pump	Pump Unit, Flammable Liquid, Self-Priming, 2 Inch, 100 GPM, Diesel Diesel Engine Centrifugal Pump

1-8. ABBREVIATIONS

Abbreviations used in this manual are in accordance with MIL-STD-12.

Section II. EQUIPMENT DESCRIPTION

1-9. PURPOSE OF CENTRIFUGAL UNIT

General purpose flammable liquid pumping applications.

1-10. CHARACTERISTICS

- Variable speed operation
- Frame mounted
- Self-priming

1-11. CAPABILITIES AND FEATURES

- Pumps at a rate of 100 gpm
- Hand crank start
- Variable speed governor
- Throttle control
- Dry-type air cleaner and rain hood
- Vertical mount muffler with protective screen

1-12. LOCATION AND DESCRIPTION OF MAJOR COMPONENTS

ENGINE (1). Power source.

MUFFLER (2). Mounts vertically on engine.

PROTECTIVE SCREEN (3). Metal safety cover for muffler.

AIR CLEANER (4). Dry-type, mounts on engine.

FUEL TANK ASSEMBLY (5). Mounts on engine.

PRIMING PORT (6). Provides access to pump housing for priming.

PUMP (7). Mounts to engine.

FUEL FILTER (8). Filters fuel to engine.

INJECTION PUMP (9). Pumps fuel to injection nozzle.

FRAME. (10). Supports engine and pump.

FUEL LIFT PUMP (11). Pumps fuel from tank to injection pump.

OIL DIPSTICK (12). Measures engine oil level.

OIL FILLER CAP (13). Provides access to engine crankcase.

THROTTLE CONTROL HAND LEVER (14). Controls engine speed.

EXTRA FUEL BUTTON (15). Provides more fuel to engine during cold starting.

GOVERNOR (16). Maintains engine speed regardless of load.

SUCTION (INTAKE) COUPLING (17). Flammable liquid inlet to pump.

DISCHARGE COUPLING (18). Flammable liquid outlet from pump.

RESTRICTION INDICATOR (19). Shows when air cleaner is restricted and needs servicing.

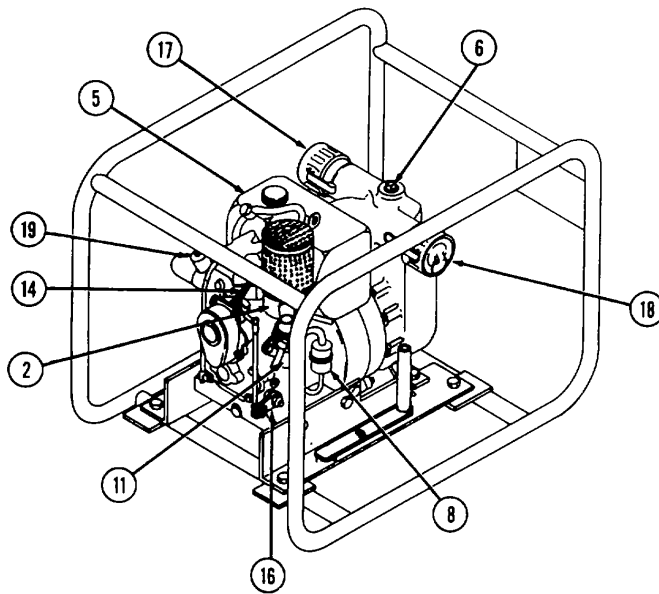
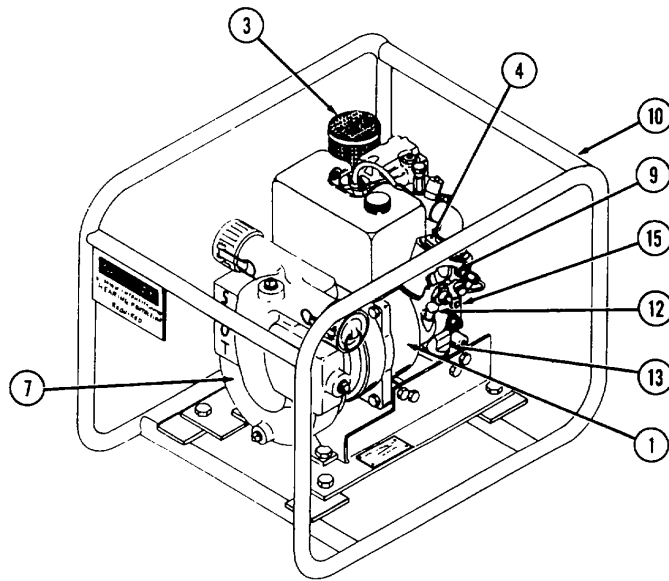

1-13. DIFFERENCES BETWEEN MODELS

This technical manual covers only Centrifugal Pump Unit, Scot Pump Division of Ardox Corporation Model 88D SPEC 3199K6. No known differences exist for this model number.

1-14. EQUIPMENT DATA

a. *Pump.*

Manufacturer..... Scot Pump Division of Ardox Corporation
 Model 88D SPEC 3199K6
 Type Self-priming centrifugal
 Service Flammable liquid
 Duty cycle Continuous
 Rated output 100 gpm (378. 5 liters) at 100 feet (30 meters) total dynamic head
 Suction (intake) port 2 inch NPT
 Discharge port 2 inch NPT
 Priming port 1 inch NPT
 Priming method..... Self-priming system
 Drain port ½ inch NPT
 RotationCounterclockwise (facing pump end)

b. *Engine*

Manufacturer Hatz Diesel
 Model E673LHK-241 A
 Horsepower 6 hp at 3600 rpm
 TypeFour stroke air-cooled diesel
 Number of cylinders 1
 Bore 2.8740 in. (73.0 mm)
 Stroke 2.6378 in. (67.0 mm)
 Compression ratio (nominal) 19 to 1
 Total displacement 17.09 cu in. (280 cm³)
 Direction of rotation (facing throttle control) Clockwise
 Number of main bearings 2

c. *Engine accessories.*

Air cleaner

Manufacturer Air-Maze
 Part Number 204-302
 Type Dry
 Filter Number 1 DM-007

d. *Capacities.*

Fuel Tank 1.04 gal (4. 0 liters)
 Engine crankcase..... 1.1 qt (1 liter)

e. *Dimensions and weight.*

Overall width19.75 in. (0.50 meter)
 Overall length28 in. (0.71 meter)
 Overall height 22.5 in. (0.57 meter)
 Gross weight 194 lb (88kg)
 Shipping volume 7.2 cu ft (0.20 m)

Section III. TECHNICAL PRINCIPLES OF OPERATION

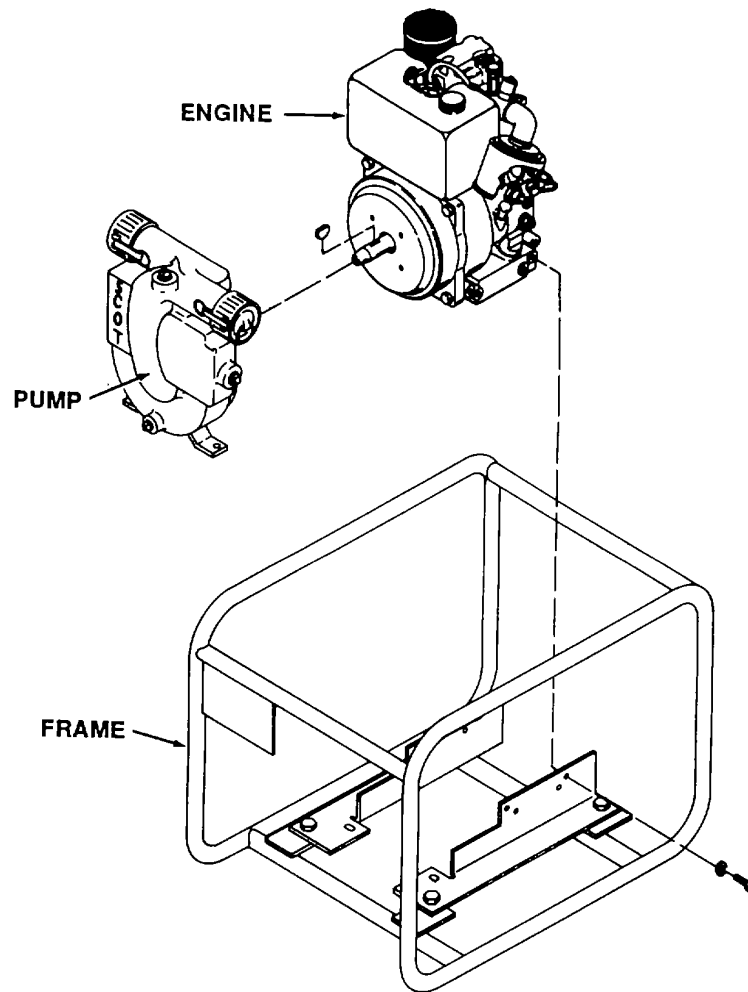
**1-15. CENTRIFUGAL PUMP UNIT**

ENGINE - Bolted to frame assembly. Provides the power necessary to drive the pump. Includes:

LUBRICATION SYSTEM - oil splash lubricates the entire drive and governor mechanisms.

COOLING SYSTEM - includes a blower ring, mounted to the flywheel, which blows cool air through crankcase housing ports onto the cylinder

FUEL SYSTEM - includes a fuel lift pump, fuel injection pump, venting pipe, fuel tank, filter and fuel pressure pipe. The fuel lift pump pumps fuel from the fuel tank through its filter, to the fuel injection pump, then to the injector through the fuel pressure pipe.

EXHAUST SYSTEM - includes a muffler and protective screen. The exhaust system transfers exhaust gases from the engine to the muffler. The muffler quiets the sound and reduces the temperature of the exhaust gases.

1-15. CENTRIFUGAL PUMP UNIT (Continued)

PUMP bolted to frame assembly. Uses power from the engine to pump flammable liquid from the suction (intake) port to the discharge port. Includes a backhead, impeller, diffuser, and housing with suction (intake) and discharge ports. The housing and backhead houses the impeller which draws flammable liquid in through the suction (intake) port and forces it out of the pump through the discharge port. The diffuser disperses the flammable liquid flow to improve pump efficiency.

FRAME ASSEMBLY - provides a movable mounting platform for the engine and pump.

CHAPTER 2
OPERATING INSTRUCTIONS

Section I. DESCRIPTION AND USE OF OPERATOR'S CONTROLS AND INDICATORS

WARNING

Personal Injury may result if the engine is not turned off during service or maintenance.

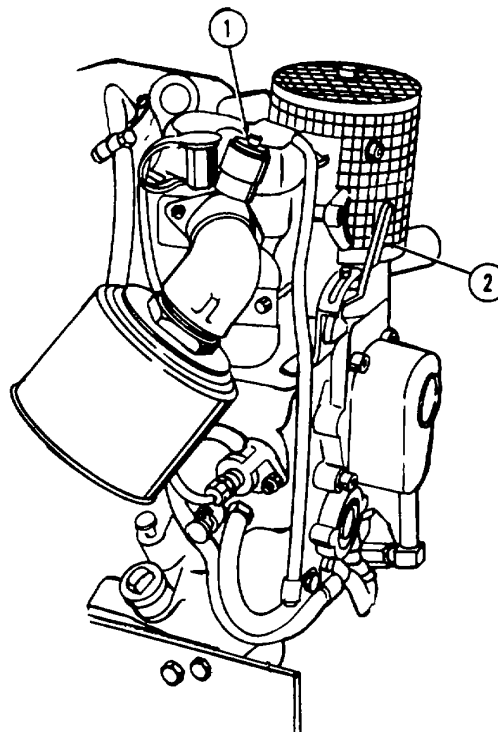

Table 2-1. Operator's Controls and Indicators

Key	Control or Indicator	Function
1	Restriction indicator	Indicates blockage of air filter. A red band appears in window to indicate the need for cleaning or replacement. Indicator is threaded into air cleaner adaptor and is actuated by high negative pressure. Indicator can be reset.
2	Throttle control hand lever	Controls engine speed. With the hand lever in START position, the engine is at highest operating speed. By moving the lever between START and STOP, the desired engine speed can be obtained.

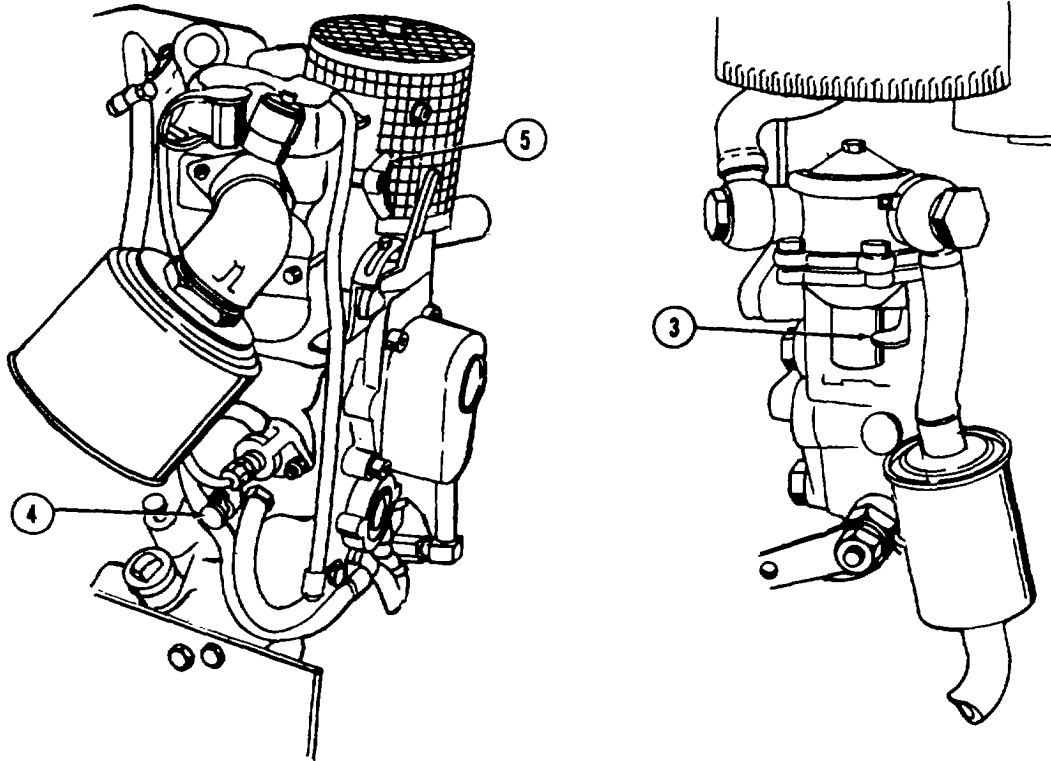

Table 2-1. Operator's Controls and Indicators (Continued)

Key	Control or Indicator	Function
3	Fuel primer lever	Mechanically connected to fuel lift pump. Used to prime engine by forcing fuel from fuel tank into fuel system.
4	Extra fuel button	Provides more fuel to engine during starting. Pulling button out allows more fuel to engine. Button returns to normal position when engine reaches operating speed.
5	Decompression lever	Controls engine decompression. Lever is placed in decompression position during engine starting and returns to compression position during starting procedure.

**Section II. OPERATOR'S PREVENTIVE
MAINTENANCE CHECK AND SERVICES (PMCS)**

2-1. GENERAL

- a. *Before you operate.* Always keep in mind the CAUTIONS and WARNINGS. Perform your before operation (B) PMCS.
- b. *While you operate.* Always keep in mind the CAUTIONS and WARNINGS. Perform your during operation (D) PMCS.
- c. *After you operate.* Be sure to perform your after operation (A) PMCS.
- d. *If your equipment fails to operate.* Troubleshoot with proper equipment. Report any deficiencies using the proper forms; see DA PAM 738-750.

2-2. PMCS PROCEDURES

- a. Table 2-2 lists the PMCS which shall be performed at specified intervals by the operator.
- b. Item numbers are assigned to each check or service task. These numbers are to be used as a source of item numbers for the TM Number column on DA Form 2404, Equipment Inspection and Maintenance Worksheet, in recording results of PMCS.
- c. The service intervals are divided into live categories; B Before Operation; D During Operation; A After operation; W Weekly; and M Monthly. A dot (-) is placed in the interval column for each check or service. If the same check or service is made in two or more intervals, a dot is placed in each applicable column.
- d. The ITEM TO BE INSPECTED column lists the item to be checked or serviced. This column is combined with the PROCEDURE column.
- e. The PROCEDURE column describes the procedure by which the check or service is to be performed. Illustrations are included to assist in locating that part of the equipment requiring the check or service.
- f. The Equipment is Not Ready/Available If: column contains the basis for classifying the equipment as not ready/available because it is unable to perform its primary mission. An entry in this column will:
 - (1) Identify conditions that make the equipment not ready/available for readiness reporting purposes.
 - (2) Deny use of the equipment until corrective maintenance has been performed.

2-2. PMCS PROCEDURES (Continued)

g. The designations left, right, front, and rear as used in the PMCS indicate the side or end of the centrifugal pump unit as viewed when facing the throttle control.

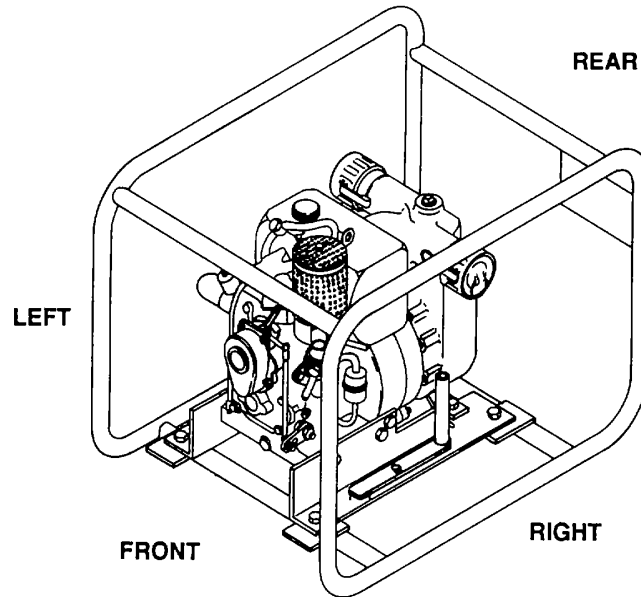

h. Leakage definitions for PMCS shall be classified as follows:

Class I Seepage of fluid (as indicated by wetness or discoloration) not great enough to form drops.

Class II Leakage of fluid great enough to form drops but not enough to cause drops to drip from item being checked/inspected.

Class III Leakage great enough to form drops that fall from item being checked/inspected.



Equipment is allowable with minor oil leakages (Class I or II). Of course, you must consider the fluid capacity in the Item/system being checked/inspected. When in doubt, notify your supervisor.

When operating with Class I or Class II oil leaks, continue to check fluid levels as required In your PMCS.

All fuel leaks and Class II oil leaks should be reported to your supervisor or unit maintenance.

Table 2-2. Operator's Preventive Maintenance Checks and Services

NOTE

If the equipment must be kept in continuous operation, check and service only those items that can be checked and serviced without disturbing operation. Make the complete checks and services when the equipment can be shut down.

Perform weekly as well as before operation PMCS if:

- (1) You are the assigned operator and have not operated the item since the last weekly.
- (2) You are operating the item for the first time.

Within designated interval, these checks are to be performed in the order listed.

B - Before Operation
D - During Operation

A - After Operation
W - Weekly

M - Monthly

ITEM NO.	INTERVAL					ITEM TO BE INSPECTED PROCEDURE	Equipment is Not Ready/ Available If
	B	D	A	W	M		
1						<p><i>Frame Assembly and Warning Plates</i></p> <ul style="list-style-type: none"> • Check attaching hardware used to mount components of centrifugal pump unit. Attaching hardware shall be tight and free of corrosion and damage. Components of pump attached directly to frame (1) are: Warning plate (2) Engine brackets (3) Identification plate (4) 	Cracks are detected, or engine is loose.

Table 2-2. Operator's Preventive Maintenance Checks and Services - Continued

B - Before Operation
D - During Operation

A - After Operation
W - Weekly

M - Monthly

ITEM NO.	INTERVAL					ITEM TO BE INSPECTED PROCEDURE	Equipment is Not Ready/ Available If:
	B	D	A	W	M		
1						<ul style="list-style-type: none"> • <i>Frame Assembly and Warning Plates - Continued</i> • Visually inspect all frame welds for cracks. Inspect only those welds that can be seen without disassembly. • Check that warning plate (2), identification plate (4), and throttle plate (5) can be read. • Check visible areas of mounting brackets(3) for corrosion damage. • Check shock mounts (6) for splitting. • Check that cranking handle (7) is securely attached to the frame. Check cranking handle (7) for corrosion or damage. • Check for indication of corrosion in areas between all mating parts. • Check condition of paint. Paint shall be in good condition with no bare metal or corrosion. 	

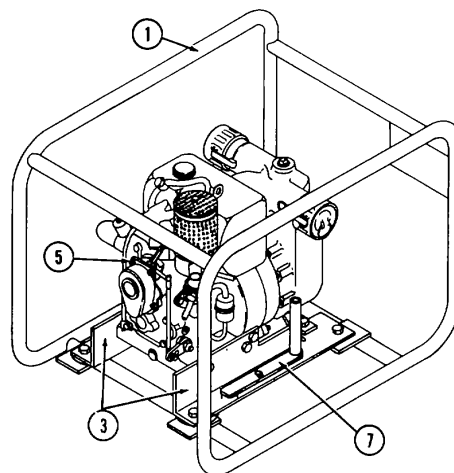
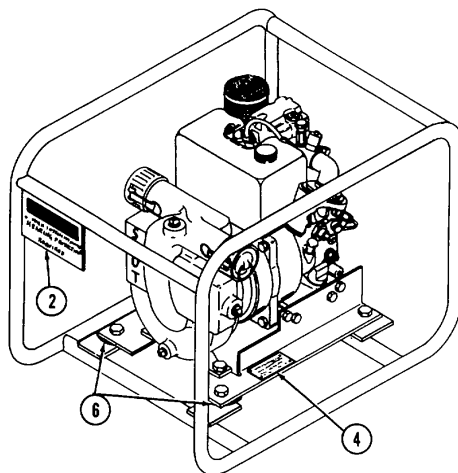

Table 2-2. Operators Preventive Maintenance Checks and Services - Continued

B - Before Operation
D - During Operation

A - After Operation
W - Weekly

M - Monthly

ITEM NO.	INTERVAL					ITEM TO BE INSPECTED	Equipment is Not Ready/ Available If:
	B	D	A	W	M		
2						<p><i>Lifting Strap (1).</i></p> <div style="border: 2px solid black; padding: 5px; text-align: center; margin: 10px 0;">WARNING</div> <p>Death or serious injury to personnel or damage to unit could occur if engine lifting strap is used to lift the centrifugal pump unit. The lifting strap shall be used to lift only the engine.</p> <ul style="list-style-type: none"> • Check for cracks in base metal and/or welds. • Check eye (2) for wear and cracks. • Check condition of paint. Paint shall be in good condition with no bare metal or corrosion. 	

Table 2-2. Operators Preventive Maintenance Checks and Services - Continued

B -Before Operation
D - During Operation

A -After Operation
W -Weekly

M - Monthly

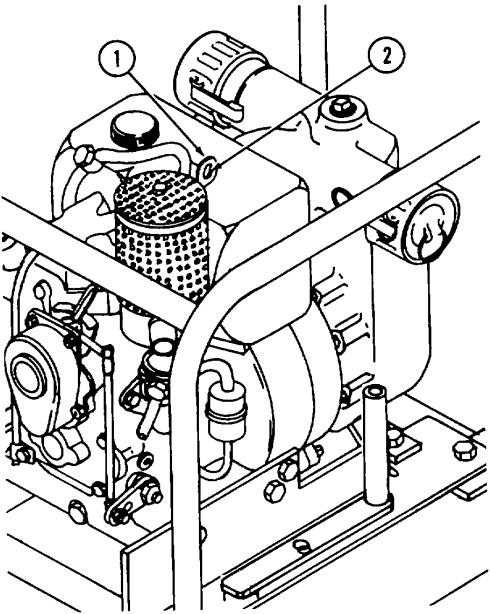
ITEM NO.	INTERVAL					ITEM TO BE INSPECTED PROCEDURE	Equipment is Not Ready/ Available If:
	B	D	A	W	M		
3						<p><i>Oil Level</i></p> <ul style="list-style-type: none"> • With engine level, remove oil dipstick (1). Wipe with lint free cloth. • Insert oil dipstick all the way into engine, then withdraw. Engine oil should coat oil dipstick to top mark. • If oil coating is below top mark, remove cap (2) and add oil to bring level up to top mark. Again check oil level. Be sure oil coats dipstick to top mark. • Check that cap (2) is tightly closed. 	Oil level is low.

Table 2-2. Operators Preventive Maintenance Checks and Services - Continued

B - Before Operation
D - During Operation

A - After Operation
W - Weekly

M - Monthly

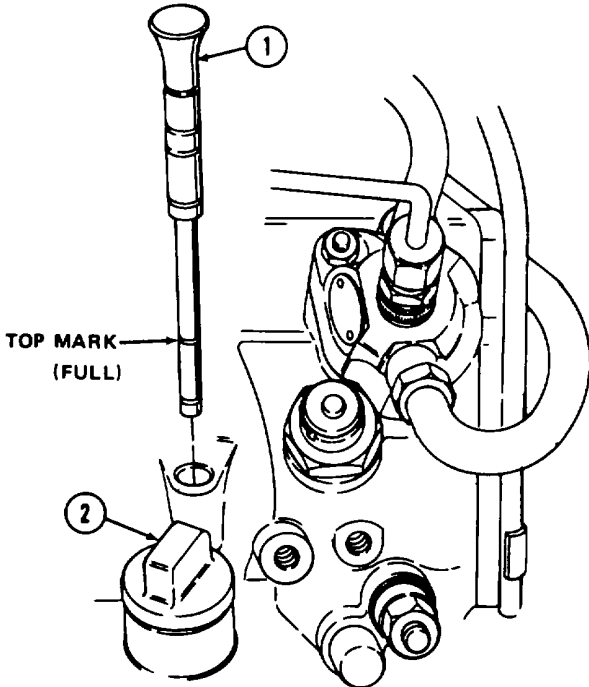
ITEM NO.	INTERVAL					ITEM TO BE INSPECTED PROCEDURE	Equipment is Not Ready/ Available If:
	B	D	A	W	M		
4						<p><i>Timing Cover and Gear Housing</i></p> <ul style="list-style-type: none"> • Check for oil leak at joint between timing cover (1) and crankcase (2). • Check for grease leak at joint between timing cover (1) and gear housing (3). • Check condition of paint. Paint shall be in good condition with no bare metal or corrosion. 	Class III oil leakage is present.

Table 2-2. Operators Preventive Maintenance Checks and Services - Continued

B - Before Operation
D - During Operation

A - After Operation
W - Weekly

M - Monthly

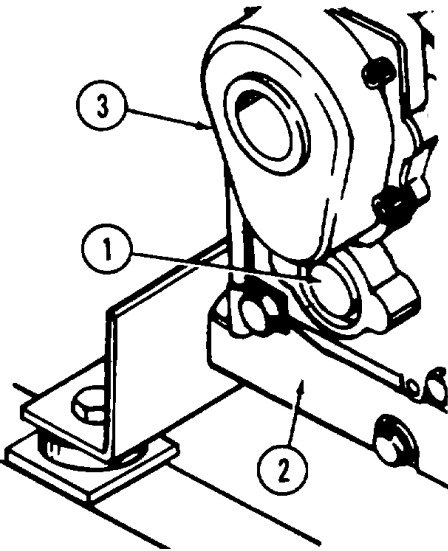
ITEM NO.	INTERVAL					ITEM TO BE INSPECTED PROCEDURE	Equipment is Not Ready/ Available If:
	B	D	A	W	M		
5						<p><i>Breather Pipe.</i></p> <p>Check for damaged or restricted breather pipe (1). Be sure bottom of breather pipe is not clogged.</p> <p>Check that pipe clip (2) is tight.</p> 	

Table 2-2. Operator's Preventive Maintenance Checks and Services (Continued)

B - Before Operation
D - During Operation

A - After Operation
W - Weekly

M - Monthly

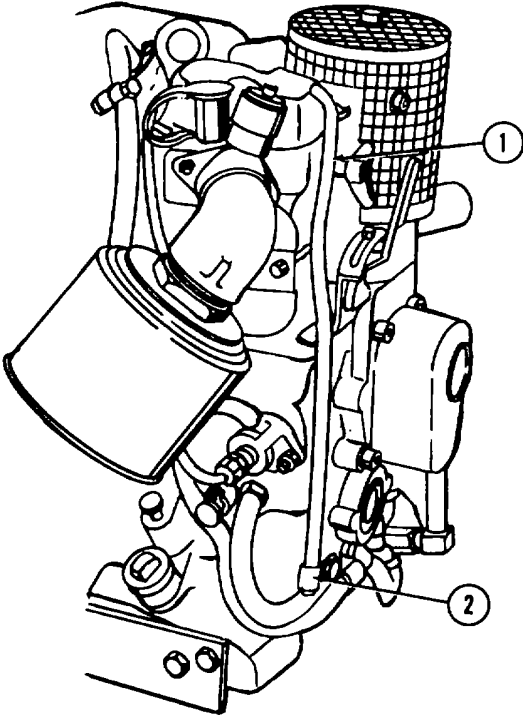
ITEM NO.	INTERVAL					ITEM TO BE INSPECTED PROCEDURE	Equipment is Not Ready/ Available If:
	B	D	A	W	M		
6						<p>Air Filter Assembly</p> <p>Check for red band in window of restriction indicator (1).</p>  <p>Check rain hood (2) for damage that could prevent the replacement of air filter, allow dirt to enter air flow after the air filter, cause restriction indicator (1) to provide inaccurate readings, or obstruct air flow to the engine.</p>	<p>Dirt in air filter blocks air flow enough to cause red band to appear in window of restriction indicator.</p> <p>Damage or blockage prevents air flow to engine and trips restriction indicator.</p>

Table 2-2. Operator's Preventive Maintenance Checks and Services (Continued)

B - Before Operation
D - During Operation

A - After Operation
W - Weekly

M - Monthly

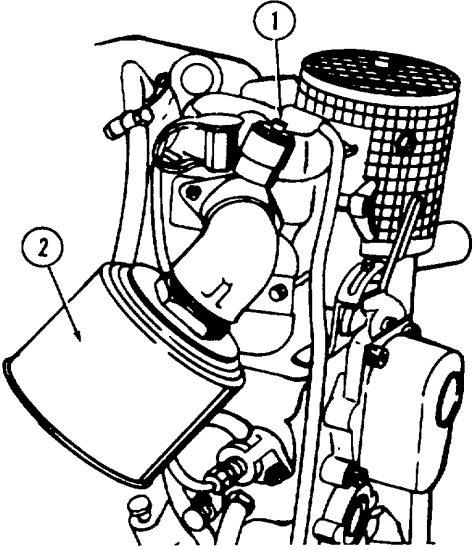
ITEM NO.	INTERVAL					ITEM TO BE INSPECTED PROCEDURE	Equipment is Not Ready/ Available If:
	B	D	A	W	M		
7						<p><i>Fuel System</i></p> <p>WARNING Death or serious injury could occur if fuel is not handled carefully. Use in a well-ventilated area away from open flame, arcing equipment, ignition sources, heaters, or excessive heat. Always store fuel in properly marked containers. DO NOT SMOKE.</p> <p>Check for leaks in fuel pressure pipe (1) and in fittings (2 and 3) at injector and at injection pump.</p> 	Leakage is present.

Table 2-2. Operator's Preventive Maintenance Checks and Services (Continued)

B - Before Operation
D - During Operation

A - After Operation
W - Weekly

M - Monthly

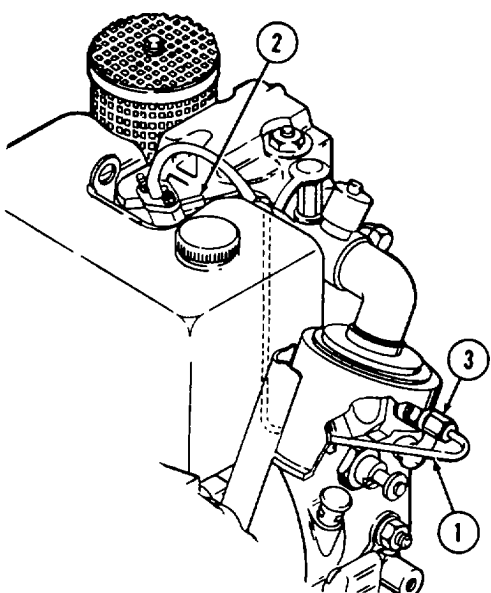
ITEM NO.	INTERVAL					ITEM TO BE INSPECTED PROCEDURE	Equipment is Not Ready/ Available If:
	B	D	A	W	M		
7	.	.	.			<p><i>Fuel System - Continued</i></p> <p>Check for fuel leakage at fittings (1) securing hoses (2) to injection pump (3).</p> 	Injection pump hose connection leaks.

Table 2-2. Operator's Preventive Maintenance Checks and Services (Continued)

B - Before Operation
D - During Operation

A - After Operation
W - Weekly

M - Monthly

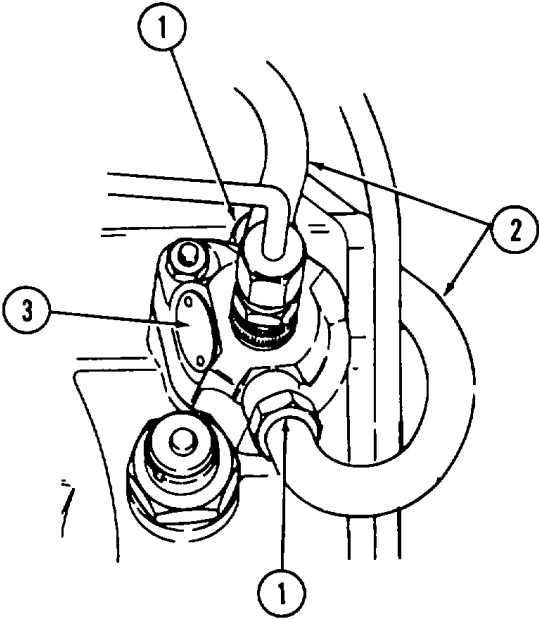
ITEM NO.	INTERVAL					ITEM TO BE INSPECTED	Equipment is Not Ready/ Available If:
	B	D	A	W	M		
7						<p><i>Fuel System (Continued)</i></p> <p>Check fuel hoses (1) for leaks at ring pieces (2) and banjo bolts (3).</p> <p>Check for fuel leaks at mating parts of fuel lift pump (4).</p> <p>Check for fuel leaks at fuel filter (5).</p> <p>Check fuel hoses (1) for leaks, cracks, holes, and abrasions, and for leaks at ring pieces (2) and banjo bolts (3).</p> 	Leakage is present or fire hazard exists.

Table 2-2. Operator's Preventive Maintenance Checks and Services (Continued)

B - Before Operation
D - During Operation

A - After Operation
W - Weekly

M - Monthly

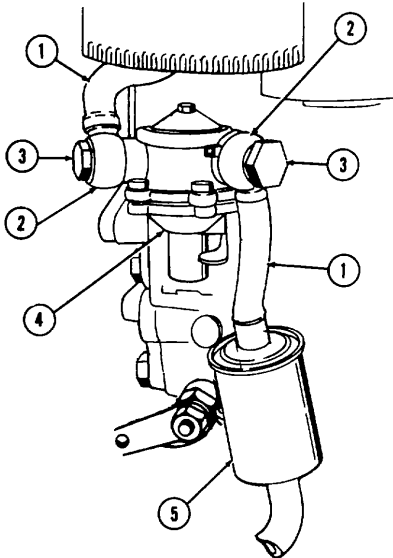
ITEM NO.	INTERVAL					ITEM TO BE INSPECTED PROCEDURE	Equipment is Not Ready/ Available If:
	B	D	A	W	M		
7						<p><i>Fuel System (Continued)</i></p> <p>Check for oil leak between fuel lift pump (1) and crankcase (2).</p> <p>Check fuel lift pump (1) for cracks, and for loose nuts (3) securing pump to crankcase (2).</p> <p>Check operation of fuel primer lever (4) at next startup. Fuel primer lever shall operate without binding to make sure fuel system is properly primed.</p> 	Class III leakage is present or fire hazard exists.

Table 2-2. Operator's Preventive Maintenance Checks and Services (Continued)

B - Before Operation
D - During Operation

A - After Operation
W - Weekly

M - Monthly

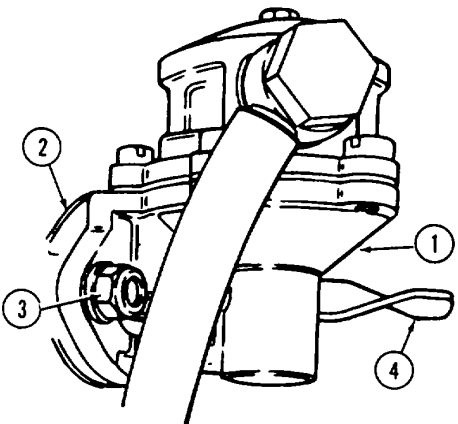
ITEM NO.	INTERVAL					ITEM TO BE INSPECTED	Equipment is Not Ready/ Available If:
	B	D	A	W	M		
7						<p><i>Fuel System (Continued)</i></p> <div style="text-align: center; border: 1px solid black; padding: 5px; width: fit-content; margin: 10px auto;"> <p>WARNING</p> </div> <p>Death or serious injury could occur if fuel is not handled carefully. Use in a well-ventilated area away from open flame, arcing equipment, ignition sources, heaters, or excessive heat. Engine must be turned off and cool before refueling. Use proper refueling procedures and equipment to avoid spillage. Do not run engine near open fuel containers. Always store fuel in properly marked containers. DO NOT SMOKE.</p> <p>Remove fuel tank cap(1). Check for adequate fuel level. Add fuel to fuel tank (2) as required.</p> 	Fuel cannot be supplied to engine.

Table 2-2.Operator's Preventive Maintenance Checks and Services (Continued)

B -Before Operation
D - During Operation

A -After Operation
W -Weekly

M - Monthly

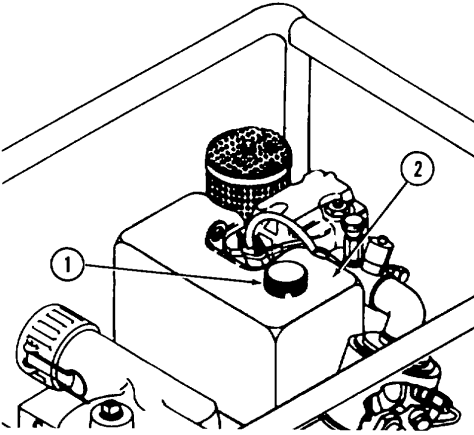
ITEM NO.	INTERVAL					ITEM TO BE INSPECTED PROCEDURE	Equipment is Not Ready/ Available
	B	D	A	W	M		
7					•	<p><i>Fuel System (Continued)</i></p> <p>Visually check fuel tank (1) for physical damage that could cause leaks or contamination of fuel supply.</p> 	Fuel cannot be supplied to engine; leakage is present.

Table 2-2. Operator's Preventive Maintenance Checks and Services (Continued)

B -Before Operation
D - During Operation

A -After Operation
W -Weekly

M - Monthly

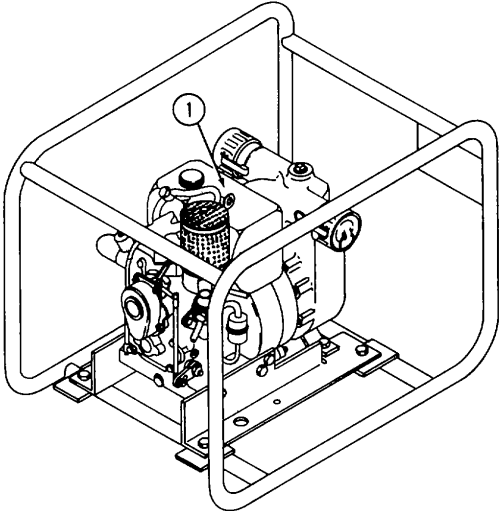
ITEM NO.	INTERVAL					ITEM TO BE INSPECTED PROCEDURE	Equipment is Not Ready/ Available
	B	D	A	W	M		
7		•				<p><i>Fuel System (Continued)</i></p> <p>Check fuel hoses (1) for leaks at banjo bolt (2) and double ring piece (3)</p> 	Fuel leaks or fire hazard resulting from leakage.

Table 2-2. Operator's Preventive Maintenance Checks and Services (Continued)

B -Before Operation
D - During Operation

A -After Operation
W -Weekly

M - Monthly

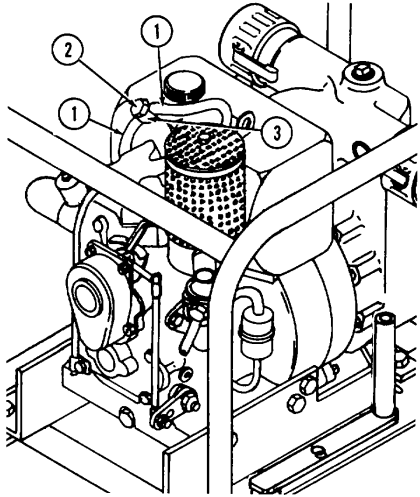
ITEM NO.	INTERVAL					ITEM TO BE INSPECTED PROCEDURE	Equipment is Not Ready/ Available If
	B	D	A	W	M		
8						<p><i>Muffler and Protective Screen</i></p> <div style="border: 2px solid black; padding: 5px; text-align: center; margin: 10px 0;"> <p>WARNINGS</p> </div> <p>Muffler and related components get hot enough during operation to cause severe burns. Avoid contact with muffler and related components during checks described in this text.</p> <p>Visually check protective screen (1) on muffler (2) for excessive vibration during operation.</p> 	Protective screen is loose.

Table 2-2. Operator's Preventive Maintenance Checks and Services (Continued)

B -Before Operation
D - During Operation

A -After Operation
W -Weekly

M - Monthly

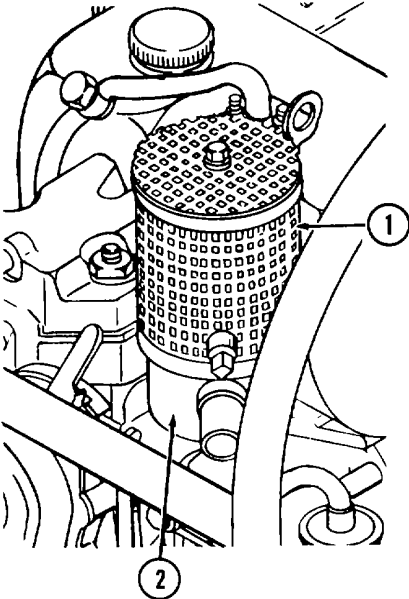
ITEM NO.	INTERVAL					ITEM TO BE INSPECTED PROCEDURE	Equipment is Not Ready/ Available If
	B	D	A	W	M		
8						<p><i>Muffler and Protective Screen (Continued)</i></p> <div style="border: 2px solid black; padding: 10px; text-align: center; margin: 10px 0;"> <h2 style="margin: 0;">WARNINGS</h2> </div> <p>Prior to touching portions of exhaust system, make sure that unit has cooled.</p> <ul style="list-style-type: none"> • Check that heat shield (1) is mounted securely to engine. • Visually inspect muffler (2) for exhaust leaks caused by damage or corrosion. 	<p>Heat shield is loose.</p> <p>Muffler is damaged or corroded.</p>

Table 2-2. Operator's Preventive Maintenance Checks and Services (Continued)

B -Before Operation
D - During Operation

A -After Operation
W -Weekly

M - Monthly

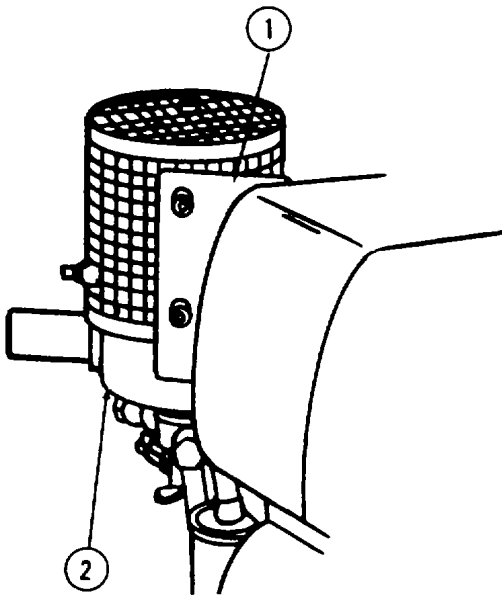
ITEM NO.	INTERVAL					ITEM TO BE INSPECTED PROCEDURE	Equipment is Not Ready/ Available
	B	D	A	W	M		
9						<p><i>Oil Drain Plug.</i></p> <p>Check oil drain plug (1) for oil leaks.</p> 	Class III oil leak is found.

Table 2-2. Operator's Preventive Maintenance Checks and Services (Continued)

B -Before Operation
D - During Operation

A -After Operation
W -Weekly

M - Monthly

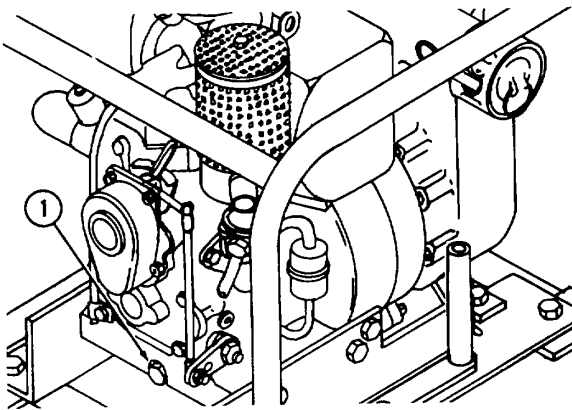
ITEM NO.	INTERVAL					ITEM TO BE INSPECTED PROCEDURE	Equipment is Not Ready/ Available If
	B	D	A	W	M		
10	• •		• •			<p><i>Pump Housing and Backhead</i></p> <p>Check that backhead (1) is securely attached to engine (2) and housing (3) is securely attached to mounting brackets (4 and 5) with screws (6).</p> <p>Check that fill pipe plug (7) and drain pipe plug (8) is securely installed in housing (3).</p> <p>Listen for unusual noise during pump operation, coming from pump housing and/or backhead.</p> <ul style="list-style-type: none"> • Check housing (3) and backhead(1) for cracks and corrosion. • Check condition of paint. condition with no bare metal or corrosion. 	<p>Pump housing or backhead screws loose or broken.</p> <p>Unusual noise</p> <p>Pump housing or backhead is cracked or damaged.</p> <p>Paint shall be in good</p>

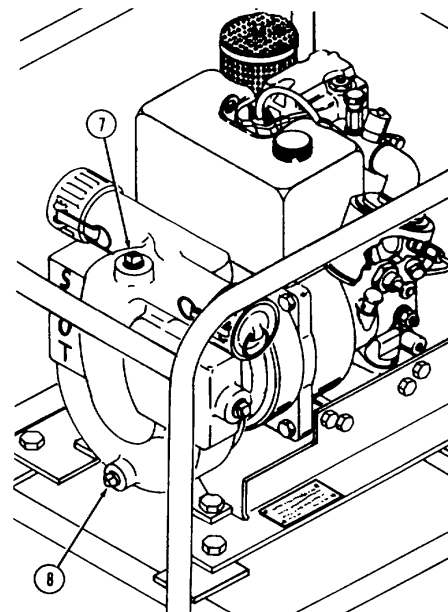
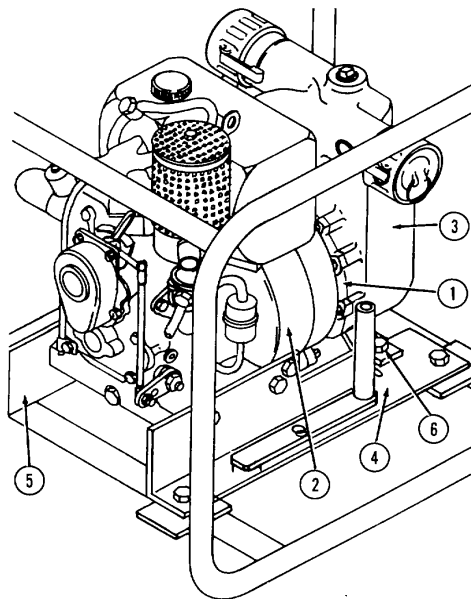

Section III. OPERATION UNDER USUAL CONDITIONS**2-3. ASSEMBLY AND PREPARATION FOR USE**

a. The centrifugal pump unit comes fully assembled, ready for use after attaching suction (intake) and discharge hoses (not supplied with unit).

(1) The pump is equipped with a 2 inch (5.08 centimeters) quick disconnect female coupling on the suction side of the pump. Remove dust plug and connect a non-collapsible hose to the suction side of the centrifugal pump unit so as to keep the suction line as short as possible. Avoid laying the line over rises which will form pockets. The highest point in the suction hose should be at the pump.

(2) Reduction in the pumping capacity becomes noticeable at lifts in excess of 15 feet (4.57 meters) and is very pronounced at 25 feet (7.62 meters). If the pump is operated at a high suction lift, use extra care that all hose connections are air tight. A small air leak in the suction line may prevent priming of the pump.

Note

Do not use the centrifugal pump unit for suction in excess of 25 feet (7.62 meters).

(3) The pump is equipped with a 2 inch (5.08 centimeters) quick disconnect male coupling on the discharge side of the pump. Remove dust cap and connect a collapsible hose to the discharge side of the pump. Make sure the hose connection is tight.

WARNINGS

The centrifugal pump unit must be connected to a suitable ground before operation. Arcing caused by a buildup of static electricity may ignite volatile fluids and cause an explosion and fire.

b. The pump unit may be grounded to an underground metallic water system, a driven metal rod or a buried metal plate. A ground rod must have a minimum diameter of 5/8 inch if solid or 3/4 inch if pipe and must be driven to a minimum depth of 8 feet. A ground plate must have a minimum area of 9 square feet and must be buried to a minimum depth of 4 feet. The ground lead must be at least number 6 average wire gauge (AWG) copper wire. If ground rod is used, connect the pump unit to the ground rod as follows:

- (1) Insert ground cable into slot in ground stud and tighten.
- (2) Connect coupling to ground rod and install driving stud. Make sure that driving stud seats on ground rod.
- (3) Drive ground rod into ground until coupling is just above surface.
- (4) Remove driving stud and install another section of ground rod making sure that it seats on first section.
- (5) Install another coupling and driving stud. Drive ground rod until new coupling is just above ground surface.
- (6) Use a minimum of three sections of 3 foot length ground rods. Add additional sections until ground rod has been driven sufficiently deep to provide effective ground.
- (7) Remove driving stud and top coupling.

2-3. ASSEMBLY AND PREPARATION FOR USE (Continued)

- (8) Connect clamp and ground cable to ground rod and securely tighten screw.
- c. Perform category B (before operation) PMCS contained in Table 2-2 or verify that category B PMCS was performed. Report any problems to unit maintenance.
- d. The following paragraphs contain instructions for starting, operating and stopping the unit.

2-4. OPERATING PROCEDURE

WARNINGS

CARBON MONOXIDE (EXHAUST GAS) CAN KILL YOU

Exposure to exhaust gases produces symptoms of headache, dizziness, loss of muscular control, drowsiness, or coma. Brain damage or death can result from severe exposure.

Fumes from engine become concentrated with poor ventilation. Operate engine in a ventilated area only.

While running engine, be alert for fumes. Keep area ventilated. If someone is overcome, expose to fresh air; keep warm and still; give artificial respiration if needed. Seek medical attention. Administer oxygen, if available.

GOOD VENTILATION IS THE BEST DEFENSE AGAINST EXHAUST POISONING.

- a. Preparation for starting.
 - (1) Move throttle control hand lever (1) fully to left past stop (2).
 - (2) Pull out extra fuel device button (3) until fully extended.
 - (3) Turn decompression lever (4) clockwise to 12 o'clock position (position 2). If decompression lever is in the 6 o'clock position, hand cranking will be extremely difficult.

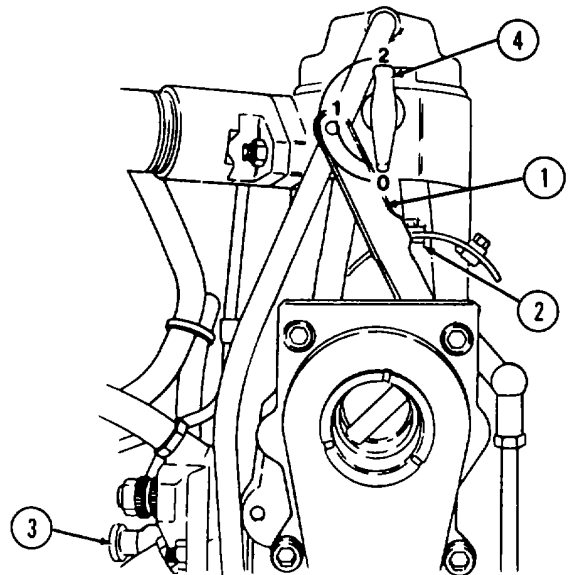

2-4. OPERATING PROCEDURE (Continued)**b. Priming Centrifugal pump.**

- (1) Remove pipe plug (1) from priming port (2).

WARNINGS

Death or serious injury could occur if fuel is not handled carefully. Use in a well-ventilated area away from open flame, arcing equipment, ignition sources, heaters, or excessive heat. Engine must be turned off and cool before refueling. Use proper refueling procedures and equipment to avoid spillage. Do not run engine near open fuel containers. Always store fuel in properly marked containers. **DO NOT SMOKE.**

- (2) Pour flammable liquid into priming port to fill housing (3). As flammable liquid fills housing, air is removed through discharge port. As the air is removed, flammable liquid from the suction side of the pump is drawn into the housing and the pump will then draw on its own.

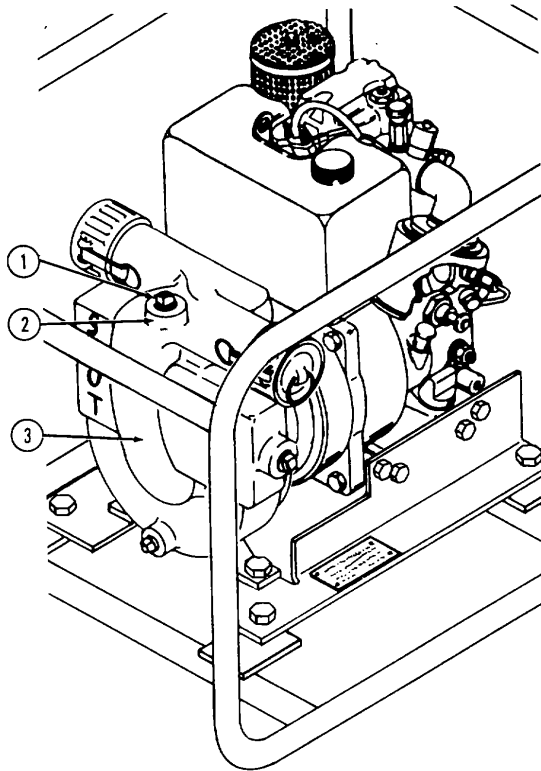

2-4. OPERATING PROCEDURE (Continued)

CAUTION

If housing does not fill with flammable liquid, check suction hose and suction hose connection at suction (intake) coupling for leaks. Be sure that suction hose end is completely immersed in flammable liquid.

- (3) Install pipe plug (1) in priming port and tighten securely.

c. *Starting.*

CAUTION

If engine does not start on initial attempt, allow engine rotation to stop completely before engaging crank handle. Prime the pump. Rotation of pump impeller without flammable fluid in housing can reduce service life of pump.

- (1) Engage crank handle (1) in gear housing (2).
- (2) Turn crank handle (1) clockwise with increasing speed.
- (3) When decompression lever (3) reaches 0 position, the highest possible speed must be obtained. Engine will start and go to maximum operating speed. Extra fuel device button (4) will return to normal position by itself.

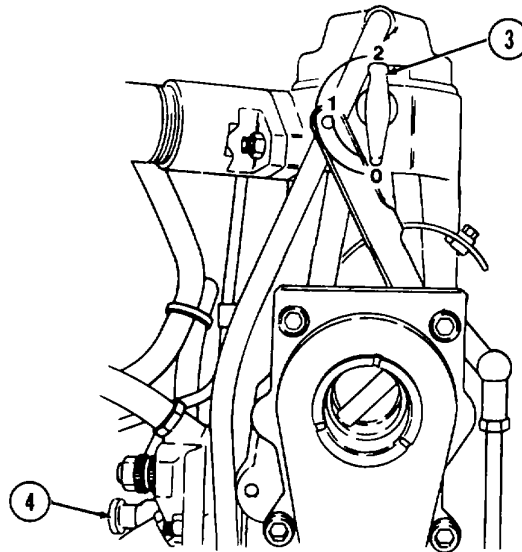
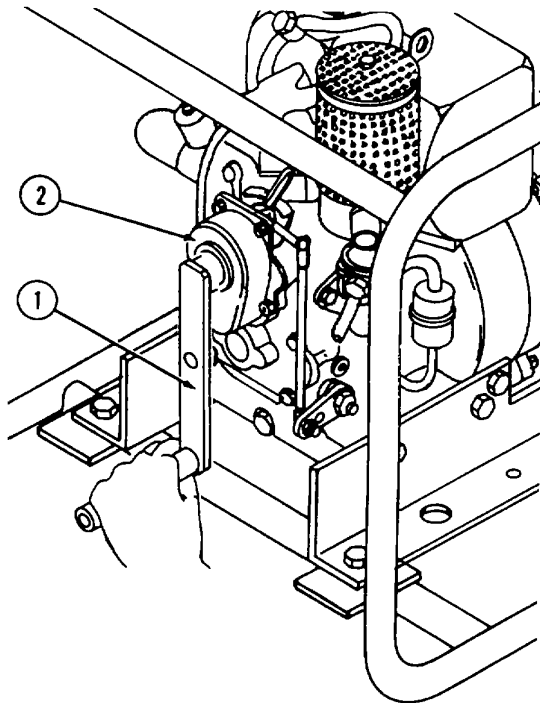

2-4. OPERATING PROCEDURE (Continued)d. *Stopping.***CAUTION**

Immediate shutdown of the engine without a 5minute idle time may cause damage to engine. Do so only when made necessary by overriding system requirements or emergency conditions.

- (1) Slowly move throttle control hand lever (1) to right position to idle speed stop (2). Allow engine to idle for 5 minutes to allow engine operating temperature to stabilize.

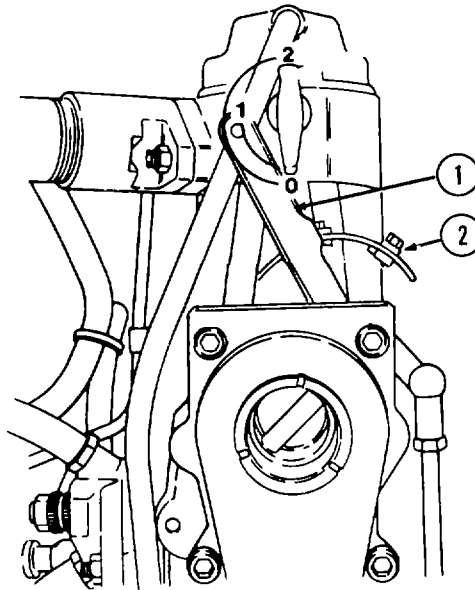
**NOTE**

If centrifugal pump unit is to be reused in its present placement and alignment, be prepared to close suction and discharge valves on hoses attached to the pump. This will retain fluid in pump housing and reduce or eliminate priming requirements.

- (2) Move throttle control hand lever (1) to extreme right position.
- (3) Close any suction and discharge couplers or adapters that are installed on hoses after operation is complete.

2-4. OPERATING PROCEDURE (Continued)

- (4) If pump is to be removed from system, remove pipe plug (1) and drain pump into a suitable container.
- (5) Remove suction hose from suction (intake) female coupling (2).
- (6) Remove discharge hose from discharge male coupling (3).
- (7) Cover suction (intake) female coupling (2) with dust plug (4).
- (8) Cover discharge male coupling (3) with dust cap (5)

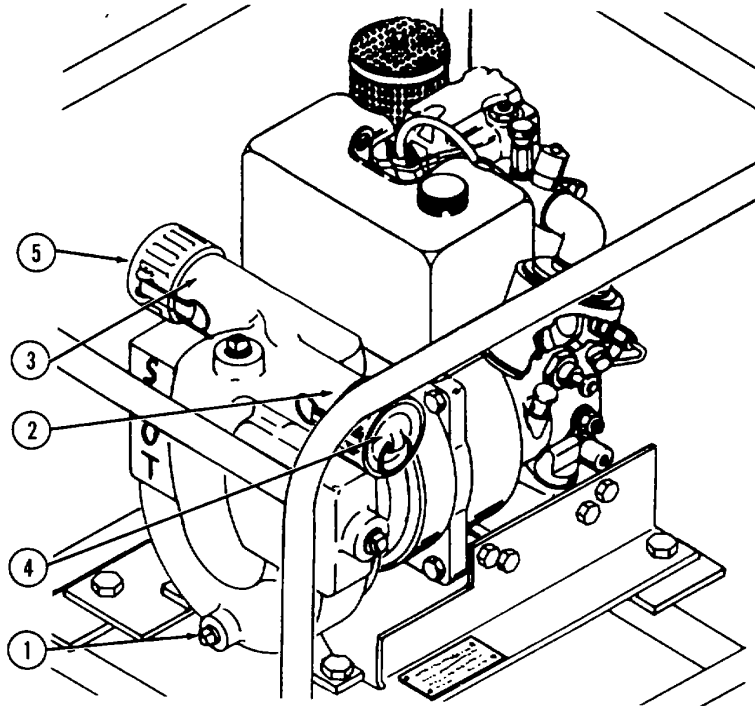

2-5. IDENTIFICATION AND WARNING PLATES

The centrifugal pump unit has the following identification and warning plates:

- a. *Identification plate.* Located on the left hand mounting bracket. Provides the pump model number, serial number, dimensions, weight, and shipping information.

PUMP ASSEMBLY, FLAMMABLE LIQUID		
NSN NO.		
CONTRACT NO.		
FSCM NO.	13646	DWG NO.
WEIGHT	LBS	S/N
SCOT DIV. ARDOX CORP. CEDARBURG, WI 53012		
117.000.549		

2-5. IDENTIFICATION AND WARNING PLATES (Continued)

b. *Engine nameplate.* Located on the flywheel end, left side of the engine. Provides engine identification.



c. *Warning plate.* Located on pump end of the centrifugal pump unit. Provides information for the safety of personnel operating the centrifugal pump unit.



Section IV. OPERATION UNDER UNUSUAL CONDITIONS

2-6. OPERATION IN COLD

- a. Use proper engine oil for cold weather. See lubrication instructions in Chapter 3.

WARNING

Death or serious injury could occur if fuel is not handled carefully. Use in a well-ventilated area away from open flame, arcing equipment, ignition sources, heaters, or excessive heat. Engine must be turned off and cool before refueling. Use proper refueling procedures and equipment to avoid spillage. Do not run engine near open fuel containers. Always store fuel in properly marked containers. **DO NOT SMOKE.**

- b. Keep fuel tank full to prevent condensation. Condensation can freeze and clog lines, filters and injectors.
- c. Cold weather starting can be improved by the addition of engine oil to the cold start assist.
- (1) With engine stopped, remove closing plug (1) from cold start assist (2).

CAUTION

Engine lockup could occur if oil is poured into center of cold start assist. Take care to fill cold start assist cup from the side.

- (2) Fill cold start assist cup with clean engine oil. To prevent engine lockup, carefully pour oil in the side of the cup.
- (3) Replace closing plug (1) into cold start assist (2) and press it in firmly.
- (4) Turn decompression lever 1/4 turn clockwise to the 9 o'clock position and turn engine with crank handle until it can be turned easily.
- (5) Start engine immediately using instructions in paragraph 2-4.

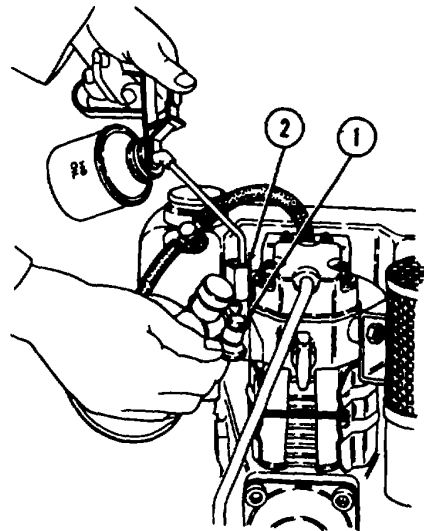

2-7. OPERATION IN EXTREME HEAT

The engine of the centrifugal pump unit is air cooled. Heat can be removed from an engine in three ways: engine exhaust, engine oil, and the passage of air across and through cylinder cooling fins. Therefore, when operating in high ambient temperatures, observe the following:

- a. With engine stopped, inspect frequently to be sure that cylinder cooling fins are clean and free of dirt that inhibits cooling.
- b. With engine stopped, inspect frequently to be sure that flywheel blower ring is clean and free of dirt.
- c. With engine stopped, inspect frequently to be sure that engine oil is to top mark on dipstick (1). Add oil, if necessary, at oil filler cap (2) to bring level up to top mark.

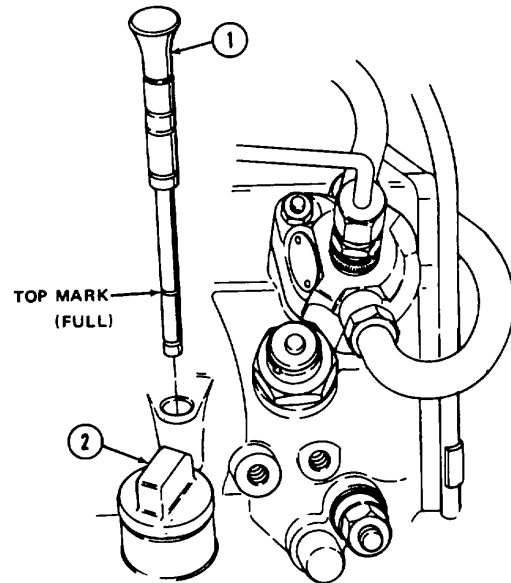

- d. Check the air cleaner restriction indicator (1). If red band appears in window of restriction indicator, change the air filter in air cleaner (2). Refer to paragraph 3-4.

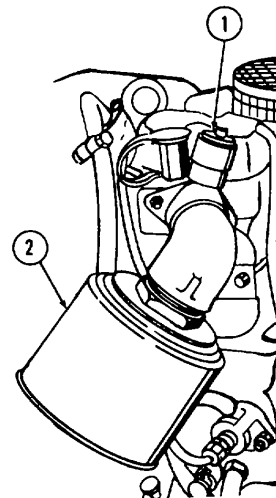

2-8. OPERATION IN HIGH ALTITUDES

The operating efficiency of the engine diminishes at higher altitudes. Be sure that engine is operating at peak efficiency.

2-9. OPERATION IN SANDY OR DUSTY AREAS**CAUTION**

Monitor air cleaner intake restriction Indicator more closely in sandy or dusty locations. At first sign of restriction, change air filter.

- a. If red band appears in window of air cleaner restriction indicator and rain hood is not blocked and no damage to system components is found, replace air filter. Refer to paragraph 34.
- b. With engine stopped, inspect frequently to be sure that cylinder cooling fins are clean and free of dirt that inhibits cooling.
- c. With engine stopped, inspect frequently to be sure that blower ring is clean and free of dirt.
- d. With engine stopped, inspect frequently to be sure that engine oil is to top mark on dipstick. Add oil, if necessary, to bring level up to top mark.
- e. During refueling and PMCS, be sure that sand or dust is not allowed to enter fuel or lubrication system.
- f. If centrifugal pump is not in use and suction and/or discharge hoses are not installed, be sure that suction (intake) and discharge couplings are covered with dust covers.
- g. Be sure that frequency of PMCS is increased in accordance with local conditions and requirements.

WARNING

Death or serious injury could occur if fuel is not handled carefully. Use in a well-ventilated area away from open flame, arcing equipment, ignition sources, heaters, or excessive heat. Engine must be turned off and cool before refueling. Use proper refueling procedures and equipment to avoid spillage. Do not run engine near open fuel containers. Always store fuel in properly marked containers. **DO NOT SMOKE.**

Check that fuel tank cap (1) is tight. Fill fuel tank (2) immediately after every operating period to prevent condensation.

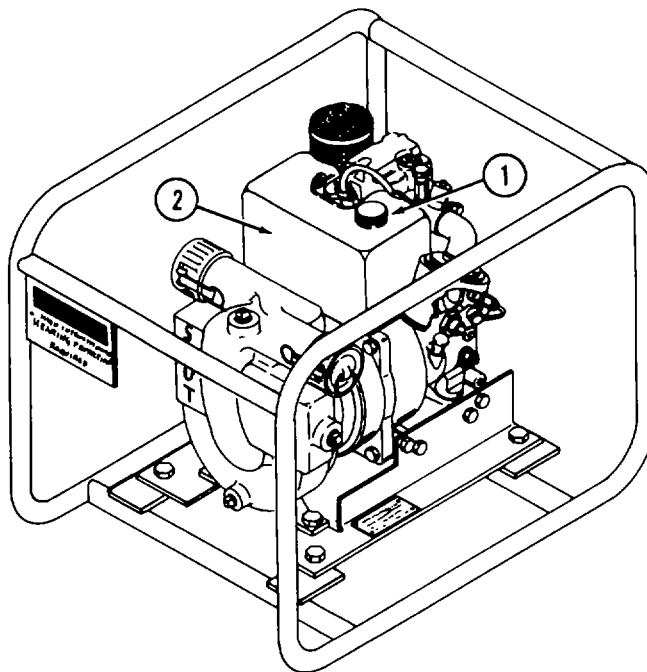
**2-11. OPERATION IN SALT WATER AREAS**

Salt water causes corrosion. Use fresh water to wash off any salt water that comes in contact with the centrifugal pump unit.

CHAPTER 3

OPERATOR MAINTENANCE INSTRUCTIONS

3-1. GENERAL

The objective of this chapter is to accurately present to the operator all those instructions and additional information needed by the operator to keep the equipment in good operating condition.

Section I. LUBRICATION INSTRUCTIONS

NOTE

These lubrication instructions are mandatory.

3-2. CHECKING ENGINE OIL LEVEL

a. With engine level, check oil level. Remove oil dipstick (1) and wipe with a lint free cloth. Insert oil dipstick all the way into engine. Withdraw dipstick. Engine oil should coat oil dipstick to top mark (2).

CAUTION

Do not overfill. Engine damage may result. If overfilled, notify unit maintenance.

b. If oil coating is below top mark (2), remove oil cap (3) and add oil of proper viscosity required by ambient temperature. See following chart.

c. Again check oil level to be sure oil coats dipstick (1) to top mark (2). Check that cap (3) is tightly closed.

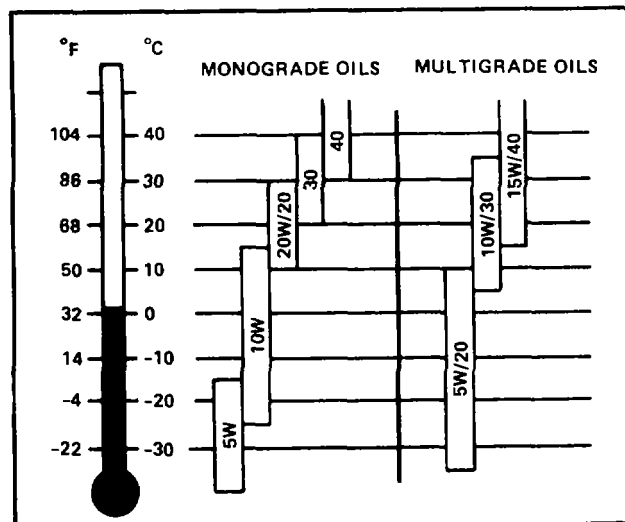
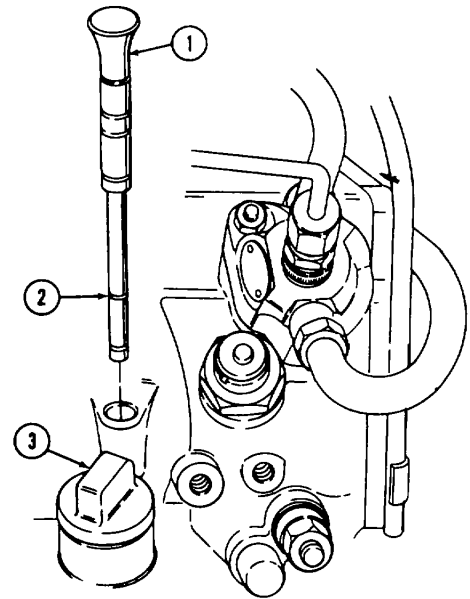

3-2. CHECKING ENGINE OIL (Continued)

d. If oil coating extends above top mark, loosen drain plug (1) enough to lower oil level to top mark on dipstick, then tighten drain plug (1) securely.

3-3. CHANGING ENGINE OIL

Change engine oil after every 150 hours of operation or every six months as follows:

- a. Remove drain plug (1) and drain oil from engine crankcase. Reinstall drain plug.
- b. Remove oil cap and add 1.1 quarts of oil of proper viscosity required by ambient temperature.
- c. Check oil level with dipstick. Reinstall oil cap.
- d. Check that oil cap is tightly closed.

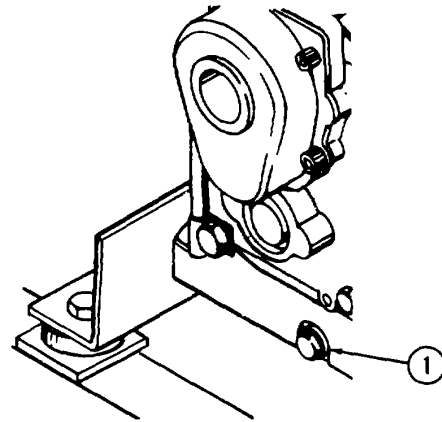

Section II. TROUBLESHOOTING PROCEDURES

3-4. TROUBLESHOOTING

- a. Table 3-1 lists common malfunctions which you may find during operation or maintenance of the centrifugal pump unit or its components. You should perform the tests/inspections and corrective actions in the order listed.
- b. This manual cannot list all malfunctions that may occur, nor all tests or inspections and corrective actions. If a malfunction is not listed or is not corrected by listed corrective actions, notify your supervisor.
- c. Only those malfunctions within the scope of operator maintenance are listed.

3-5. SYMPTOM INDEX

Refer to the Symptom Index below. Locate the malfunction which is the same, or most nearly the same, as the trouble you are having with the centrifugal pump unit. The Symptom Index lists the first page of the troubleshooting information for that malfunction. Follow the steps one by one, and perform the corrective actions listed.

Symptom Index

Malfunction Number	Description	Page
1	Engine hard to crank	3-3
2	Engine fails to crank	3-3
3	Engine cranks but fails to start	3-3
4	Uneven running or frequent stalling	3-4
5	Lack of power	3-4
6	Dense smoke from exhaust after warm-up	3-5
7	Unit overheats (erratic operation, lack of power)	3-5

Symptom Index (Continued)

Malfunction Number	Description	Page
8	Engine stops running	3-6
9	Excessive lubrication consumption	3-6
10	Pump fails to prime	3-7
11	Noisy pump operation	3-7
12	Low discharge pressure	3-7

Table 3-1. Operator Troubleshooting

MALFUNCTION	TEST OR INSPECTION	CORRECTIVE ACTION
-------------	--------------------	-------------------

1. ENGINE HARD TO CRANK

Step 1. Check for proper oil.
Refer to chart in paragraph 3-2.

Step 2. Change oil
Refer to paragraph 3-3.

2. ENGINE FAILS TO CRANK

Notify unit maintenance.

2. ENGINE CRANKS BUT FAILS TO START

WARNINGS

Death or serious injury could occur if fuel is not handled carefully. Use in a well-ventilated area away from open flame, arcing equipment, ignition sources, heaters, or excessive heat. Engine must be turned off and cool before refueling. Use proper refueling procedures and equipment to avoid spillage. Do not run engine near open fuel containers. Always store fuel in properly marked containers. **DO NOT SMOKE.**

Step 1. Check for insufficient fuel supply. Fill fuel tank.

Step 2. Check air cleaner restriction indicator.
If red band appears in window of restriction indicator, and rain hood is not blocked and no damage to system components is found, replace air filter (para 3-4).

Step 3. Check starting procedures under prevailing conditions.
If starting procedures have been performed correctly, but engine still fails to start, notify unit maintenance. 3-3

Table 3-1. Operator Troubleshooting (Continued)

MALFUNCTION	TEST OR INSPECTION	CORRECTIVE ACTION
-------------	--------------------	-------------------

4. UNEVEN RUNNING OR FREQUENT STALLING

WARNINGS

Death or serious injury could occur if fuel is not handled carefully. Use in a well-ventilated area away from open flame, arcing equipment, ignition sources, heaters, or excessive heat. Engine must be turned off and cool before refueling. Use proper refueling procedures and equipment to avoid spillage. Do not run engine near open fuel containers. Always store fuel in properly marked containers. **DO NOT SMOKE.**

CAUTION

A high temperature condition may cause abnormal engine operation.

- Step 1. Check for insufficient fuel supply.
Fill fuel tank.
- Step 2. Check air cleaner restriction indicator.
If red band appears in window of restriction indicator, and rain hood is not blocked and no damage to system components is found, replace air filter (para 3-4).

5. LACK OF POWER

- Step 1. Check for low engine speed. Move throttle control hand lever to left past stop.

WARNINGS

Death or serious injury could occur if fuel is not handled carefully. Use in a well-ventilated area away from open flame, arcing equipment, ignition sources, heaters, or excessive heat. Engine must be turned off and cool before refueling. Use proper refueling procedures and equipment to avoid spillage. Do not run engine near open fuel containers. Always store fuel in properly marked containers. **DO NOT SMOKE.**

- Step 2. Check for insufficient fuel supply.
Fill fuel tank.

Table 3-1. Operator Troubleshooting (Continued)

MALFUNCTION	TEST OR INSPECTION	CORRECTIVE ACTION
Step 3.	Clean air cleaner restriction indicator.	If red band appears in window of restriction indicator, and rain hood is not blocked and no damage to system components is found, replace air filter (para 34).
Step 4.	Check for loose connections or a restricted or damaged line between fuel lift pump and tank, between fuel lift pump and injection pump, and between injection pump and injector. Tighten loose connections. Report damaged lines to unit maintenance.	
Step 5.	Check for restrictions in suction or discharge hoses or hose end.	Clean away debris. If hoses are severely damaged or restricted, replace.
6. DENSE SMOKE FROM EXHAUST AFTER WARMUP		
Step 1.	Shut down engine. With engine level, check oil level (para 3-2)	Add oil if necessary.
Step 2.	Check window of air cleaner restriction indicator for red band indicating blocked air cleaner.	If red band appears in window of restriction indicator, and rain hood is not blocked and no damage to system components is found, replace air filter (para 34).
Step 3.	Notify unit maintenance.	
7. UNIT OVERHEATS (ERRATIC OPERATION, LACK OF POWER)		
Step 1.	Check cylinder cooling fins for damage or dirt.	Remove accumulated dust and dirt. Start engine after cleaning.
Step 2.	Shut down engine. With engine level, check oil level (para 3-2).	Add oil if necessary.
Step 3.	Check muffler for obstruction.	Remove obstruction.
Step 4.	Notify unit maintenance.	

Table 3-1. Operator Troubleshooting (Continued)

MALFUNCTION	TEST OR INSPECTION	CORRECTIVE ACTION
-------------	--------------------	-------------------

8. ENGINE STOPS RUNNING

WARNINGS

Death or serious injury could occur if fuel is not handled carefully. Use in a well-ventilated area away from open flame, arcing equipment, ignition sources, heaters, or excessive heat. Engine must be turned off and cool before refueling. Use proper refueling procedures and equipment to avoid spillage. Do not run engine near open fuel containers. Always store fuel in properly marked containers. **DO NOT SMOKE.**

Step 1. Check for insufficient fuel supply.
 Fill fuel tank.

Step 2. Check air cleaner restriction indicator.
 If red band appears in window of restriction indicator, and rain hood is not blocked and no damage to system components is found, replace air filter (para 3-4).

9. EXCESSIVE LUBRICATING OIL CONSUMPTION

Step 1. Check for leakage at oil drain plug or oil filler cap.
 If drain plug or oil filler cap is leaking, try to tighten. If leak continues, notify unit maintenance.

Step 2. Check for leakage at joint between timing cover and crankcase.
 Notify unit maintenance.

Step 3. Check for leakage around cylinder head.
 Notify unit maintenance.

Step 4. Check for smoky exhaust (See Malfunction 5). If exhaust discharge contains oil, excessive oil is being burned in engine cylinder or around cylinder valve stems.
 Notify unit maintenance.

Table 3-1. Operator Troubleshooting (Continued)

MALFUNCTION	TEST OR INSPECTION	CORRECTIVE ACTION
-------------	--------------------	-------------------

10. PUMP FAILS TO PRIME

- | | | |
|---------|--|--|
| Step 1. | Check for low engine speed. | Move throttle control hand lever to left past the stop. |
| Step 2. | Check for air-locked pump. | Vent the pump housing and fill with flammable liquid (para 2-4.b). |
| Step 3. | Check for leaks at the suction (intake) flange and gasket. | Replace gasket. |

11. NOISY PUMP OPERATION

CAUTION

Excessive pump noise can indicate that pump is running dry. This condition can cause serious pump damage.

- | | | |
|---------|---|---|
| Step 1. | Check that suction hose is properly connected to container from which flammable liquids being pumped. Flammable liquid level in container shall be above suction hose connection. | |
| Step 2. | Check suction hose and coupling for foreign material. | With engine stopped and suction hose removed, inspect interior of suction hose and suction (intake) coupling for foreign material or obstruction. |
| Step 3. | Check suction hoses, connections, or suction coupling interface for leaks. | |
| Step 4. | Check that pump has been properly primed. | If necessary, prime the pump (para 2-4.b). |
| Step 5. | Notify unit maintenance. | |

12. LOW DISCHARGE PRESSURE

- | | | |
|---------|--|---|
| Step 1. | Check for low engine speed. | Move throttle control hand lever to left past the stop. |
| Step 2. | Check suction (intake) line for leaking connections. | Tighten loose connections. |

Section III. MAINTENANCE PROCEDURES

3-6. CLEANING OR REPLACING AIR FILTER ELEMENT

This task covers: a. Removal c. Installation
 b. Cleaning

REMOVAL:

- 1 Remove wing nut (1) and sealing washer (2).
- 2 Remove air filter top (3) and air filter element (4).
- 3 Separate from base connector (7), gasket (6) and rain hood (5).

Wipe rain hood and air filter top with clean, dry cloth.

CLEANING:



Death or serious injury could occur if compressed air is directed against the skin. Do not use compressed air for cleaning or drying unless the pressure is/has been reduced to 30 psi (2.06 bar) or less. When working with compressed air always use chip guards, eye protection, and other personal equipment.



Air pressure of greater than 30 psi (2.06 bar) will damage the air filter

The use of cleaning fluids will damage the air filter.

- 1 Clean air filter element (4) with air and/or warm water [70° F to 100° water/mild detergent solution.
- 2 Rinse and allow to dry.
- 3 If air filter element cannot be cleaned, replace it.

INSTALLATION:

1 Install air filter element (4) into rain hood (5) and place air filter top (3) over air filter element. Place gasket (6) on rain hood.

2 Align hole in rain hood and air filter top with threaded rod on base connector (7).

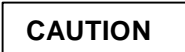

Overtightening the wing nut will deform the element.

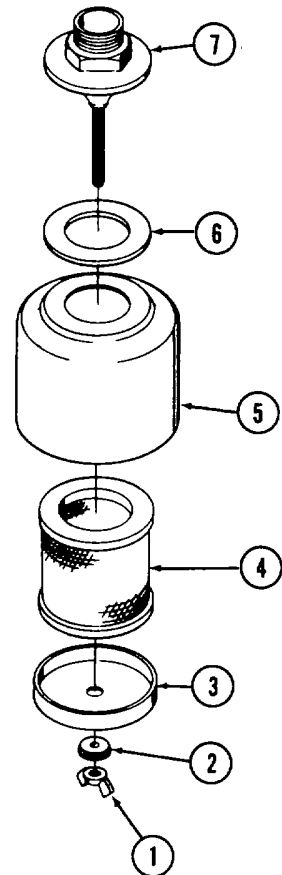

3-6. CLEANING OR REPLACING AIR FILTER (Continued)

- 3 Install sealing washer (2) and wing nut (1).
- 4 Hand tighten wing nut as necessary to make sure the air filter assembly is secure and vibration free.
- 5 Reset restriction indicator (1).

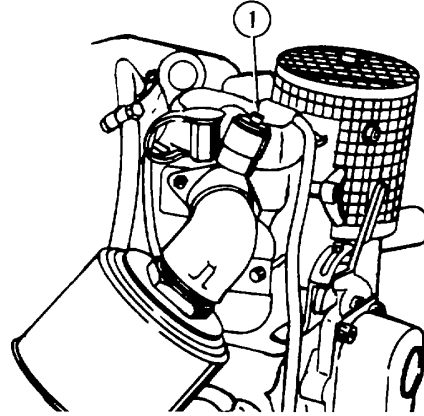

OPERATIONAL CHECK:



Muffler and related components get hot enough during pump operation to cause severe burns. Avoid contact with muffler and related components during checks described in this text. Exposure to exhaust gases produces symptoms of headache, dizziness, loss of muscular control, drowsiness, or coma. Brain damage or death can result from severe exposure. Fumes from engine become concentrated with poor ventilation. Operate engine in a ventilated area only. While running engine, be alert for fumes. Keep area ventilated. If someone is overcome, expose to fresh air; keep warm and still; give artificial respiration if needed. Seek medical attention. Administer oxygen, if available.

GOOD VENTILATION IS THE BEST DEFENSE AGAINST EXHAUST POISONING.

- 1 Start engine and observe air cleaner assembly and restriction indicator (1) for looseness, rattles, or leaks. Tighten.
- 2 If red band is visible in window of restriction indicator (1), shut down engine.
- 3 Recheck installation and air filter element. Reset restriction indicator (1).
- 4 Restart engine. If red band is still visible, notify unit maintenance.
- 5 Restart engine and check restriction indicator (1). If restriction indicator still shows red band, refer to unit maintenance.

CHAPTER 4 UNIT MAINTENANCE

Section I. REPAIR PARTS, SPECIAL TOOLS, TMDE, AND SUPPORT EQUIPMENT

4-1. COMMON TOOLS AND EQUIPMENT

For authorized common tools (standard and metric) and equipment, refer to the Modified Table of Organization and Equipment (MTOE) applicable to your unit.

4-2. SPECIAL TOOLS, TMDE, AND SUPPORT EQUIPMENT

The special tools required to service the centrifugal pump unit are listed and illustrated in TM 5-4320-310-24P, Repair Parts and Special Tools List (RPSTL).

4-3. REPAIR PARTS

Repair parts are listed and illustrated in Repair Parts and Special Tools List (RPSTL) TM 5-4320-310-24P covering Unit, Direct Support and General Support maintenance for the equipment.

Section II. SERVICE UPON RECEIPT OF EQUIPMENT

4-4. UNLOADING EQUIPMENT

- a. Before attempting to unload the centrifugal pump unit, make sure the unloading facility is capable of handling 194 pounds (88 kilograms).
- b. Remove shipping tiedowns.

**WARNING**

Death or serious injury could occur if unauthorized or unnecessary personnel are in the hoisting area. Permit only personnel actually engaged in the hoisting operation to be near the unit and hoisting equipment. All Instructions for the hoisting operations must come from one authorized person.

Injury or damage to the unit could occur from improper hoisting. Hoist the load slowly to avoid tearing out lifting strap, slipping slings, or load shift. Do not jerk the load or swing it from side-to-side when hoisting. This places additional stress on hoisting components which can cause failure and loss of load. Be sure hoisting equipment is on a solid footing and is suitable for the size of the load. Watch boom angle and overhead clearance when hoisting.

Death or serious injury to personnel or damage to unit could occur if engine lifting strap is used to lift the centrifugal pump unit. The lifting strap shall be used to lift only the engine.

- c. Unload the centrifugal pump unit with a lifting device secured to the frame assembly.

4-5. INSPECTING EQUIPMENT

- a. Inspect the unit for damage incurred during shipment. If the unit has been damaged, report the damage on SF Form 364, Report of Discrepancy.
- b. Check the unit against packing slip to see if the shipment is complete. Report all discrepancies in accordance with the instructions of DA PAM 738-750.
- c. Check to see whether the unit has been modified.

4-6. SETUP INSTRUCTIONS

- a. Locate unit as close as possible to flammable liquid to be pumped. Keep the suction hose and the amount of lift as short as possible.
- b. The operating site should be as level as possible (no more than 20 degrees slope) or the engine lubrication system may not work properly.
- c. Keep the suction and discharge hoses as short and straight as possible.
- d. Allow adequate space to permit support of the suction and discharge hoses where they enter the pump.
- e. Remove dust plug and connect the suction hose to suction (intake) female quick disconnect coupling half (1). Highest point in the suction hose should be at the pump.
- f. Remove dust cap and connect discharge hose to discharge male quick disconnect coupling half (2).
- g. Make sure that connections are tight.

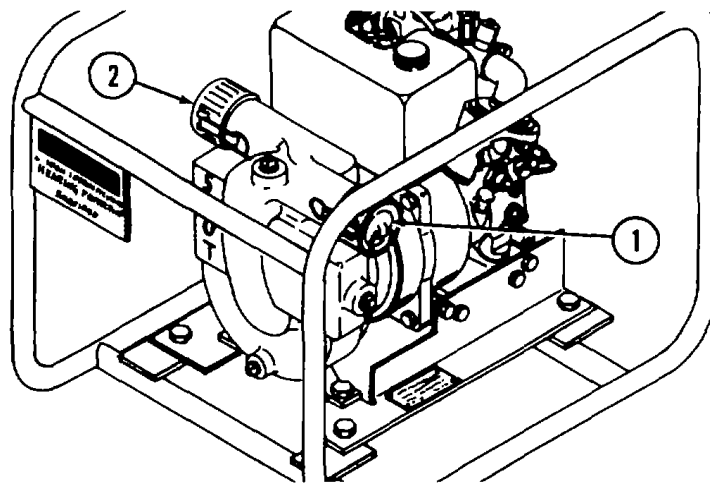

WARNINGS

The centrifugal pump unit must be connected to a suitable ground before operation. Arcing caused by a buildup of static electricity may ignite volatile fluids and cause an explosion and fire.

- h. The pump unit may be grounded to an underground metallic water system, a driven metal rod or a buried metal plate. A ground rod must have a minimum diameter of 5/8 inch if solid or 3/4 inch if pipe and must be driven to a minimum depth of 8 feet. A ground plate must have a minimum area of 9 square feet and must be buried to a minimum depth of 4 feet. The ground lead must be at least number 6 average wire gauge (AWG) copper wire. If ground rod is used, connect the pump unit to the ground rod as follows:

4-6. SETUP INSTRUCTIONS Continued

- (1) Insert ground cable into slot in ground stud and tighten.
- (2) Connect coupling to ground rod and install driving stud. Make sure that driving stud seats on ground rod.
- (3) Drive ground rod into ground until coupling is just above surface.
- (4) Remove driving stud and install another section of ground rod making sure that it seats on first section.
- (5) Install another coupling and driving stud. Drive ground rod until new coupling is just above ground surface.
- (6) Use a minimum of three sections of 3 foot length ground rods. Add additional sections until ground rod has been driven sufficiently deep to provide effective ground.
- (7) Remove driving stud and top coupling.
- (8) Connect clamp and ground cable to ground rod and securely tighten screw.

4-7. PRELIMINARY SERVICING AND ADJUSTMENT OF EQUIPMENT SETUP**WARNING**

Death or serious injury could occur if fuel is not handled carefully. Use in a well ventilated area away from open flame, arcing equipment, ignition sources, heaters, or excessive heat. Engine must be turned off and cool before refueling. Use proper refueling procedures and equipment to avoid spillage. Do not run engine near open fuel containers. Always store fuel in properly marked containers. **DO NOT SMOKE.**

- a. Be sure fuel tank has sufficient fuel.
- b. With engine level, check oil level. remove oil dipstick (1) and wipe with a lint free cloth. Insert oil dipstick all the way into the engine. Withdraw dipstick. Engine oil should coat oil dipstick to top mark (2).

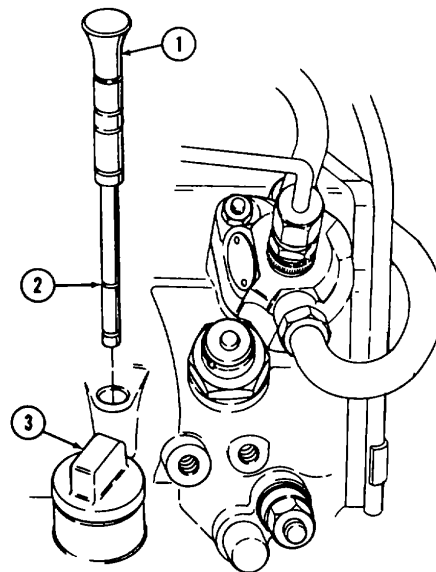

4-7. PRELIMINARY SERVICING AND ADJUSTMENT OF EQUIPMENT SETUP (Continued)

CAUTION

Do not overfill. Engine damage could result.

c. If oil coating is below top mark (2), remove oil cap (3) and add oil of proper viscosity required by ambient temperature. See following chart.

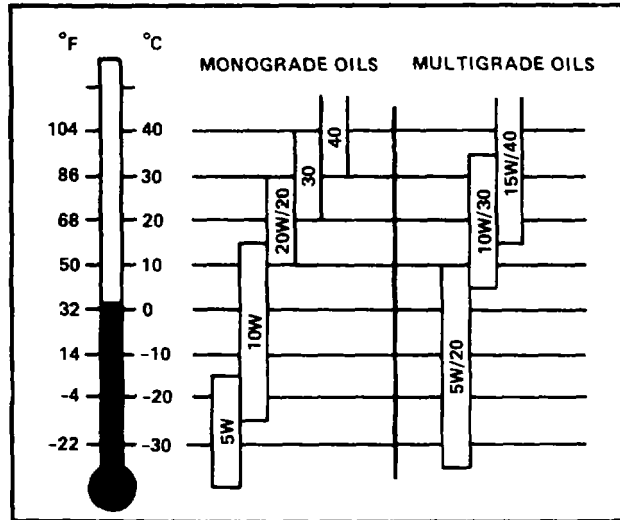

d. Again check oil level to be sure oil coats dipstick (1) to top mark (2). Check that oil cap (3) is tightly closed.

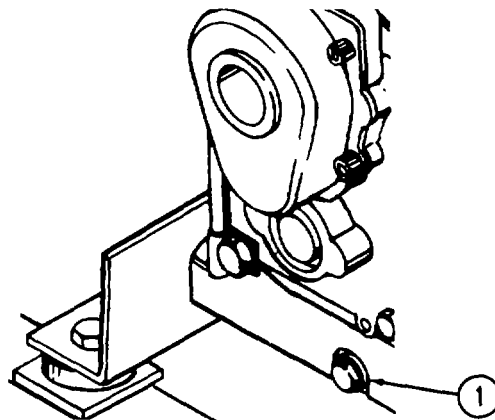

e. If oil coating extends above top mark, loosen drain plug (1), drain enough oil to lower oil level to top mark on dipstick, then tighten drain plug securely.

f. Refer to table 4-1 and perform preventive maintenance checks and services.

Section III. PREVENTIVE MAINTENANCE CHECKS AND SERVICES

4-8. PREVENTIVE MAINTENANCE CHECKS AND SERVICES

Table 4-1 lists preventive maintenance checks and services (PMCS) which shall be performed at specified intervals by unit maintenance personnel. It expands upon the preventive maintenance services performed by operator maintenance and includes additional services which are allocated to unit maintenance. The columns, codes, and location designations used in the table are as follows:

a. Item numbers are assigned to each check or service task. The numbers are to be used as a source of item numbers for the TM Number column on DA form 2404, Equipment Inspection and Maintenance Worksheet, in recording results of PMCS.

b. The service intervals are divided into four categories: W-Weekly; M-Monthly; O-Quarterly; Semiannually. A dot (-) is placed in the interval column for each check or service. If the same check or service is made in two or more intervals, a dot is placed in each applicable column.

The Item to be Inspected column lists the item to be checked or serviced.

d. The Procedures column describes the procedure by which the check or service is to be performed. Illustrations are included to assist in locating that part of the unit requiring the check or service.

e. The designations left, right, front, and rear as used in the PMCS indicate the side or end of the centrifugal pump unit as viewed when facing the throttle control.

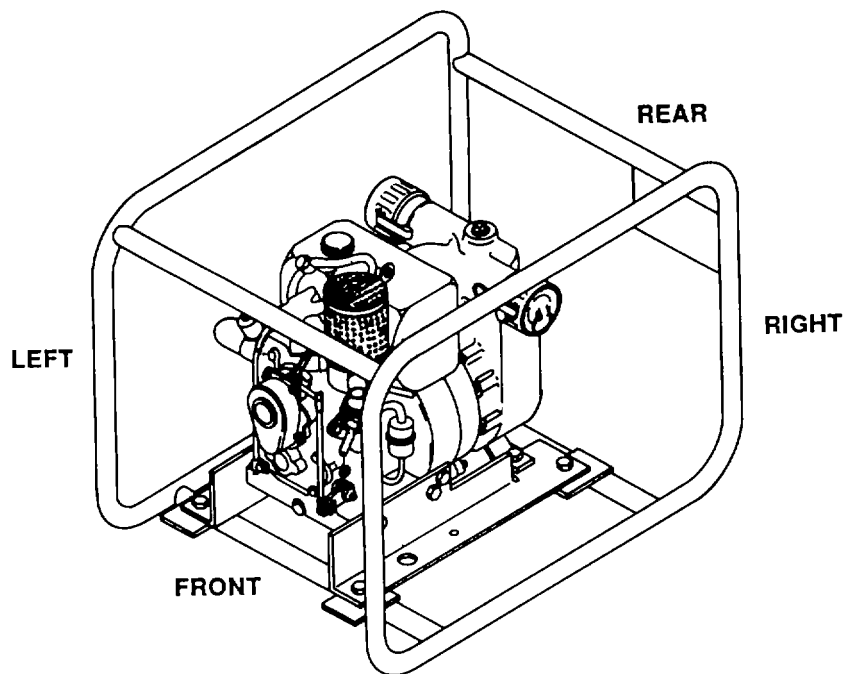

Table 4-1. Unit Preventive Maintenance Checks and Services

CAUTION

During PMCS It may be necessary to run engine. Since the pump is directly coupled to the engine, the pump will run when the engine runs. Running the pump for longer than a few seconds without liquid in the housing will damage the pump. When necessary to run the pump for longer than a few seconds, make sure that suction and discharge hoses are installed and a source of flammable liquid is available. Prime pump, start engine to duplicate normal operation and prevent pump from overheating.

W -Weekly
M - Monthly

Q - Quarterly
S - Semiannually

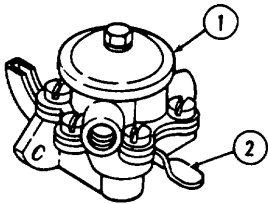
Item No.	Interval				Procedures	Equipment is Not Ready/ Available
	W	M	Q	S		
	1			•	<p>Fuel Lift Pump</p> <p>WARNING</p> <p>Death or serious Injury could occur if fuel is not handled carefully. Use in a well-ventilated area away from open flame, arcing equipment, ignition sources, heaters, or excessive heat. Always store fuel in properly marked containers. DO NOT SMOKE.</p> <p>Check fuel lift pump (1) for leakage. Check operation of primer lever (2).</p> 	Fuel lift pump leaks.

Section IV. TROUBLESHOOTING

4-9. TROUBLESHOOTING

a. Table 4-2 contains troubleshooting information for locating and correcting most of the operating troubles which are the responsibility of unit maintenance. Each malfunction for an individual component, unit, or system is followed by a list of tests or inspections which will help you to determine probable causes and corrective actions to take. Perform the tests/inspections and corrective actions in the order listed.

b. This manual cannot list all malfunctions that may occur, nor all tests or inspections and corrective actions. If a malfunction is not listed or is not corrected by listed corrective actions, notify your supervisor.

c. Only those functions within the scope of unit maintenance are listed. For troubleshooting procedures within the scope of operator maintenance, refer to table 3-1.

4-10. SYMPTOM INDEX

Refer to the Symptom Index below. Locate the malfunction which is the same, or most nearly the same, as the trouble you are having with the centrifugal pump unit. The Symptom Index lists the first page of the troubleshooting information for that malfunction. Follow the steps one by one, and perform the corrective actions listed.

Symptom Index

Malfunction Number	Description	Page
1	Engine fails to crank	4-7
2	Engine cranks but fails to start	4-7
3	Engine runs unsteadily and power output is low	4-9
4	Dense smoke from exhaust after warm-up	4-9
5	Engine overheats	4-9
6	Pump makes excessive noise	4-9
7	Pump output low	4-9

Table 4-2. Unit Maintenance Troubleshooting

**MALFUNCTION
TEST OR INSPECTION
CORRECTIVE ACTION**

1. ENGINE FAILS TO CRANK

Correction of malfunction is beyond unit maintenance.
Notify direct support maintenance.

2. ENGINE CRANKS BUT FAILS TO START

- Step 1. Check that extra fuel button has been pulled out prior to starting.
Pull out extra fuel button and attempt to start engine (para 2-4.c)
- Step 2. Check non-return valve for proper function

Table 4-2. Unit Maintenance Troubleshooting (Continued)

MALFUNCTION
TEST OR INSPECTION
CORRECTIVE ACTION

WARNING

Death or serious injury could occur if fuel is not handled carefully. Use in a well-ventilated area away from open flame, arcing equipment, ignition sources, heaters, or excessive heat. Always store fuel in properly marked containers. DO NOT SMOKE.

- a. Disconnect hose (1) from double ring piece (2) at fuel tank (3). Turn engine with crank handle (4).
- b. If fuel does not flow from hose (1), remove non-return valve (5). Check valve by shaking for free movement of internal valve ball.
- c. If necessary, clean with fuel. If unserviceable, replace non-return valve (5) (para 4-17).

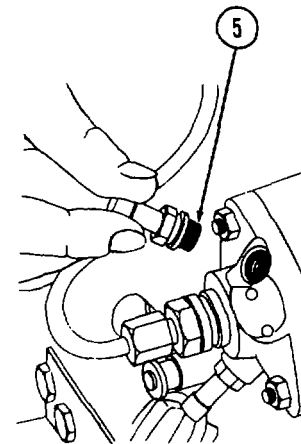
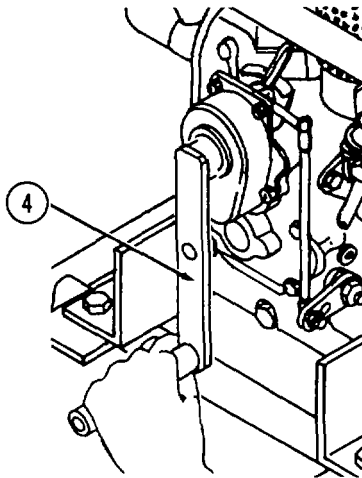
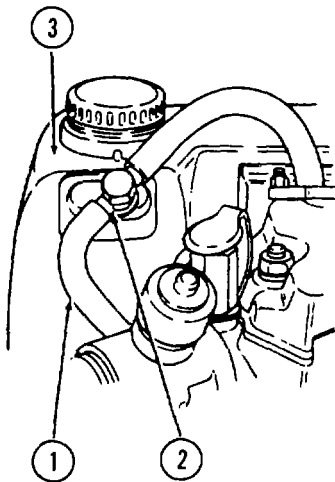

Step 3. Check that fuel flows through fuel system components (fuel tank, fuel lift pump, fuel filter and fuel lines) as engine is cranked by disconnecting component outlet hose(s).

Replace defective component.

Fuel tank - Refer to paragraph 4-19.

Fuel lift pump - Refer to paragraph 4-18.

Fuel filter - Refer to paragraph 4-17.

Fuel lines - Refer to paragraph 4-17.

Step 4. Notify direct support maintenance.

Table 4-2. Unit Maintenance Troubleshooting (Continued)

MALFUNCTION	TEST OR INSPECTION	CORRECTIVE ACTION
3. ENGINE RUNS UNSTEADILY AND POWER OUTPUT IS LOW	<p>Step 1. Check fuel system components and lines. See Malfunction 2, step 2 and 3.</p> <p>Step 2. Notify direct support maintenance.</p>	
4. DENSE SMOKE FROM EXHAUST AFTER WARM-UP	<p>Step 1. Adjust valve clearance (para 4-22).</p> <p>Step 2. Notify direct support maintenance.</p>	
5. ENGINE OVERHEATS	<p>Correction of malfunction is beyond unit maintenance.</p> <p>Notify direct support maintenance.</p>	
6. PUMP MAKES EXCESSIVE NOISE	<p>Step 1. Check and tighten as required, loose backhead and housing mounting bolts.</p> <p>Step 2. Remove housing. Check for loose or damaged diffuser and/or impeller (para 4-14).</p> <p>Step 3. Replace damaged component parts.</p>	
7. PUMP OUTPUT LOW	<p>Step 1. Check that engine speed is properly adjusted.</p> <p>Replace/adjust throttle control (para 4-21).</p> <p>Step 2. See Malfunction 6, steps 1 thru 3.</p>	

Section V. MAINTENANCE PROCEDURES

INDEX Table 4-2. Unit Maintenance Troubleshooting (Continued)

MALFUNCTION**TEST OR INSPECTION****CORRECTIVE ACTION**

	Para		Para
Air cleaner	4-15	Fuel lines, hoses, and fittings	4-17
Air filter Assembly	4-15	Fuel tank	4-19
Backhead	4-14	Impeller	4-14
Coupling halves	4-12	Muffler	4-20
Cold start assist	4-16	Pump housing	4-13
Cylinder head and valve assembly	4-22	Restriction indicator	4-15
Diffuser	4-14	Shaft seal	4-14
Fuel filter	4-17	Stub Shaft	4-14
Fuel lift pump	4-18	Throttle control	4-21

4-11. GENERAL INSTRUCTIONS

Maintenance instructions in this section will list resources required, personnel required, and equipment condition for the start of the procedure. Note the following:

- Resources required are not listed unless they apply to the procedure.
- Personnel required are listed only if the task requires more than one. If PERSONNEL is not listed, it means one person can do the task.
- The normal standard equipment condition to start a maintenance task is engine stopped. EQUIPMENT CONDITION is not listed unless some other condition is required.

4-12. REPLACE SUCTION AND DISCHARGE QUICK DISCONNECT COUPLING HALVES

This task covers: a. Removal c. Installation
 b. Inspection

INITIAL SETUP**Tools**

(A) Tool Kit, General Mechanics Automotive
 (Item 1, Appendix B)

Equipment Condition

Engine shut down, suction and discharge hoses removed, flammable liquid drained from pump via drain port at bottom of pump assembly.

REMOVAL:

- 1 Disengage dust plug (1).
- 2 Remove damaged suction (intake) quick disconnect coupling half (2) from pump housing assembly (3).
- 3 Remove gasket from coupling half (2).
- 4 Disengage dust cap (4).
- 5 Remove gasket from dust cap (4).
- 6 Remove damaged discharge quick disconnect coupling half (5) from pump housing assembly (3).

INSPECTION:

- 1 Inspect coupling halves (2 and 5) for cracks, worn or damaged threads and other signs of damage.
- 2 Inspect gaskets for wear and deterioration.
- 3 Replace any worn or damage parts.

INSTALLATION:

- 1 Screw suction (intake) quick disconnect coupling half (2) into pump housing assembly (3). Install new gasket fully into quick disconnect coupling half (2).
- 2 Install dust plug (1).
- 3 Screw discharge quick disconnect coupling half (5) into pump housing assembly (3). Install new gasket fully into quick disconnect dust cap (4).
- 4 Install dust cap (4).

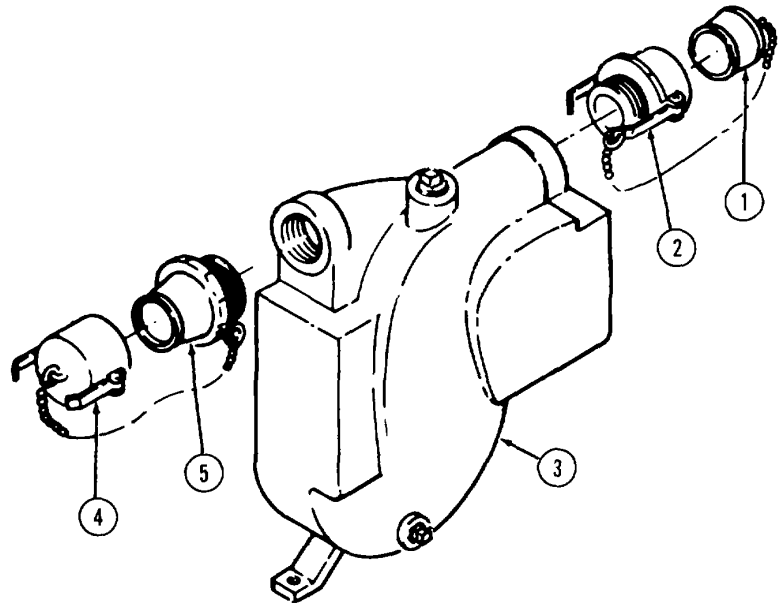

4-12. REPLACE SUCTION AND DISCHARGE QUICK DISCONNECT COUPLING HALVES

This task covers: a. Removal c. Installation
 b. Inspection

INITIAL SETUP

Tools

(A) Tool Kit, General Mechanics Automotive
 (Item 1, Appendix B)

Equipment Condition

Engine shut down, suction and discharge hoses removed, flammable liquid drained from pump via drain port at bottom of pump assembly.

REMOVAL:

- 1 Remove two screws (1), nuts (2), lock washers (3) and flat washers (4) securing pump housing assembly (5) to frame assembly.
- 2 Remove eight screws (6) and flat washers (7) securing pump housing assembly (5) to backhead.

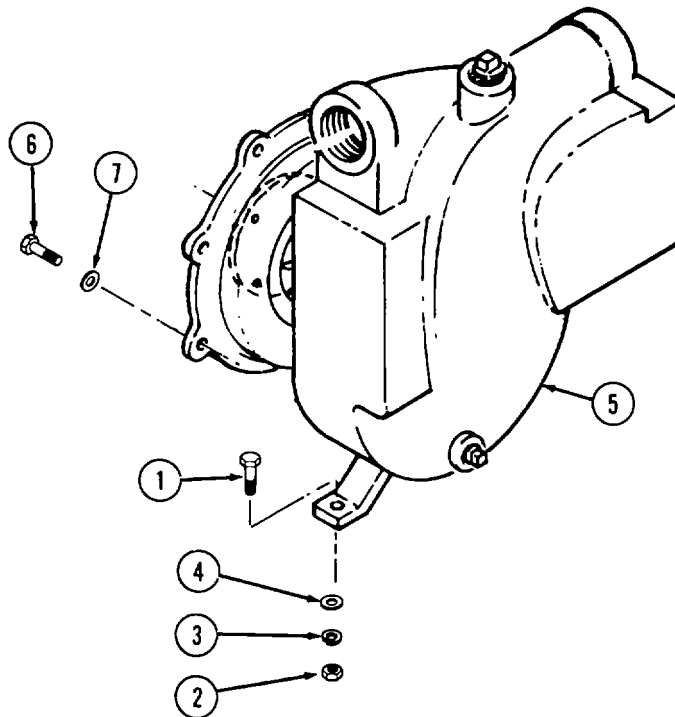

4-13. REPLACE PUMP HOUSING ASSEMBLY (Continued)

CLEANING:

WARNING

Dry cleaning solvent P-D-680 (safety or Stoddard's Solvent) is potentially dangerous. Avoid repeated and prolonged breathing of vapors and skin contact with the liquid. Do not use near open flame, arcing equipment, or other ignition sources. Always wear eye protection and protective clothing. The flash point of P-D-68[⊕] is 100[⊕]F to 138[⊕]F (38[⊕]C to 59[⊕]C).

Death or serious injury could occur if compressed air is directed against the skin. Do not use compressed air for cleaning or drying unless the pressure is/has been reduced to 30 psi (2.06 bar) or less. When working with compressed air always use chip guards, eye protection, and other personal equipment.

Clean with solvent and dry with compressed air.

INSPECTION:

- 1 Inspect pump housing assembly for rust, corrosion, cracks or other damage. Replace pump housing assembly if damaged.
- 2 Inspect threaded holes for damage to threaded inserts (8). If threads are damaged, notify direct support maintenance.

INSTALLATION:

- 1 Install eight screws (6) and flat washers (7) in inserts (8) in pump housing assembly (5). Tighten evenly in an alternating pattern to 50 inch-pounds.
- 2 Install screws (1) through pump assembly (5) legs and mounting brackets on frame assembly, and secure with nuts (2), new lock washers (3) and flat washers (4).

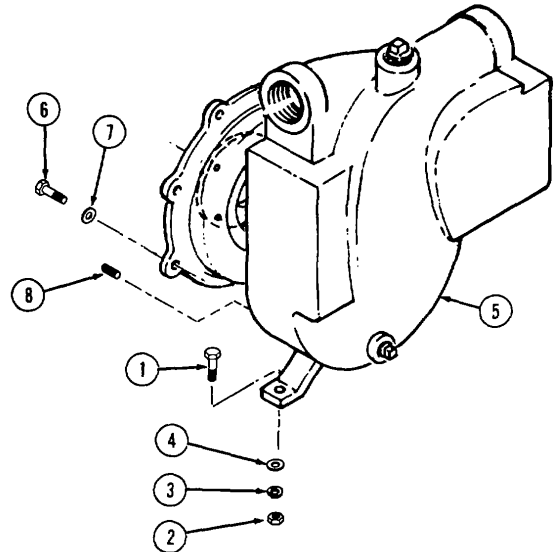

4-14. REPLACE DIFFUSER, IMPELLER, SHAFT SEAL, BACKHEAD AND STUB SHAFT

This task covers:	a.	Removal	c.	Inspection
	b.	Cleaning	d.	Installation

INITIAL SETUP

Tools

Tool Kit, General Mechanics Automotive (Item 1, Appendix B)
 Puller (Item 2, Appendix B)

Torque Wrench (Item 2, Appendix B)

Materials/Parts

Dry cleaning solvent (Item 10, Appendix E)
 Silicone (Item 2, Appendix E)
 Lockwashers, preformed packing, shims

Equipment Condition

Para **Equipment Condition**
 4-13 Quick disconnect coupling halves and pump housing assembly removed.

General Safety Instructions

Well-ventilated area required during cleaning.

REMOVAL:

- 1 Disengage diffuser assembly (2) from impeller (4). Remove spring pin (1) only if damaged.
- 2 Hold impeller assembly (4) stationary and remove hexagon head cap screw (5) and impeller washer (6). Unless impeller is corroded, it can be slipped off stub shaft (7) without force. Remove impeller assembly. Pull key (8) from stub shaft (7).
- 3 Remove shims (9) if present, shaft seal assembly (10) parts noting their orientation and preformed packing (11); discard preformed packing (11).

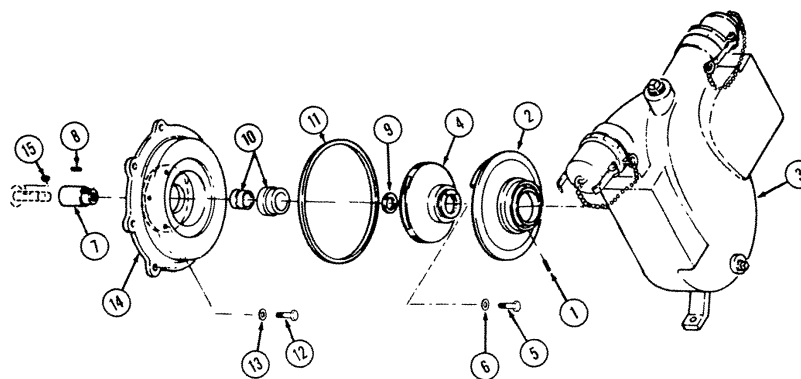

4-14. REPLACE DIFFUSER, IMPELLER, SHAFT SEAL, BACKHEAD AND STUB SHAFT (Continued)

- 4 Remove four hexagon head bolts (12) and lock washers (13) and carefully pull backhead (14) from engine.
- 5 Remove stub shaft (7) from engine crankshaft with a puller. Be careful not to lose key (15).

CLEANING:**WARNING**

Dry cleaning solvent P-D-680 (safety or Stoddard's Solvent) is potentially dangerous. Avoid repeated and prolonged breathing of vapors and skin contact with the liquid. Do not use near open flame, arcing equipment, or other ignition sources. Always wear eye protection and protective clothing. The flash point of P-D-680 is 100OF to 138OF (380C to 590C).

Death or serious injury could occur if compressed air is directed against the skin. Do not use compressed air for cleaning or drying unless the pressure is/has been reduced to 30 psi (2.06 bar) or less. When working with compressed air always use chip guards, eye protection, and other personal equipment.

Clean all removed parts with P-D-680 dry cleaning solvent and dry with compressed air. Use a probe to remove any obstructions from impeller assembly (4) vanes.

INSPECTION:

- 1 Use a feeler gauge and inspect wear rings on mating diffuser assembly (2) and impeller assembly (4) for excessive wear. If wear ring clearance exceeds 0.030 inch per side, 0.060 inch diameter, notify direct support maintenance.
- 2 Inspect mating lapped surfaces on stationary and rotary elements of shaft seal (10) for uneven wear, grooves burning or other similar damage. If any of these conditions exist, or if flammable fluid leakage was noted at the rear of the backhead, replace the shaft seal.
- 3 Inspect all other parts for excessive wear, rust, corrosion or other damage. Replace any other worn or damaged parts.

INSTALLATION:

- 1 Press stub shaft (7) fully onto crankshaft being sure key (15) is in place.
- 2 Carefully install backhead (14) over stub shaft (7) and secure to engine with four hexagon head bolts (12) and new lock washers (13). Torque hexagon head bolts evenly in an alternating pattern to 40 inch-pounds.
- 3 Apply silicone to new preformed packing (11). Install preformed packing (11) onto backhead (14).
- 4 Apply silicone to shaft seal assembly (10). Carefully and in the proper orientation, press shaft seal assembly parts over stub shaft and fully into backhead (14) recess.

4-14. REPLACE DIFFUSER, IMPELLER, SHAFT SEAL, BACKHEAD AND STUB SHAFT (Continued)

NOTE

If the same Impeller assembly (4) and backhead (14) are reassembled and no clearance change was required, make sure the same thickness of shims (9) is used.

- 5 If a new impeller assembly (4) or backhead (14) is to be installed, or if the impeller assembly clearance is to be changed, determine shim (9) thickness required to obtain a clearance of $1/16 \pm 0.001$ inch (1.59 ± 0.025 mm) between the impeller assembly and backhead as follows:
 - a. Without using shims (9), press impeller assembly (4) firmly onto stub shaft (7) and rotate impeller assembly. If no rubbing is heard or felt between impeller assembly (4) and backhead (14), no shims (9) are required.
 - b. If rubbing occurs, remove the impeller assembly (4), add a few shim laminations, press impeller assembly firmly onto stub shaft (7) and again rotate impeller assembly.
 - b. Repeat steps a. and b. until clearance between impeller assembly (4) and backhead (14) just occurs.
 - c. Then remove impeller assembly (4) and remove installed shims (9). Install key (8) into stub shaft (7) keyway and reinstall removed shims plus an additional $1/16$ inch (1.59 mm) thickness of shims (9).
- 6 Install impeller assembly (4) and secure with impeller washer (6) and hexagon head cap screw (5). Impeller washer beveled face is to be oriented toward the screw head. Torque hexagon head cap screw to 80 inch-pounds.
- 7 Install diffuser assembly (2) in pump housing assembly (3) engaging spring pin (1) with slot in pump housing assembly.

4-15. REPLACE AIR FILTER ASSEMBLY

This task covers: a. Removal c. Repair e. Installation
 b. Disassembly d. Assembly f. Operational Check

INITIAL SETUP**Tools**

Tool Kit, General Mechanics Automotive
 (Item 1, Appendix B)
 Pipe Wrench (Item 2, Appendix B)
 Pliers, Slip Joint, 9" Long (Item 2, Appendix B)

General Safety Instructions

Unit must be cool. Well-ventilated area
 required during operational check.

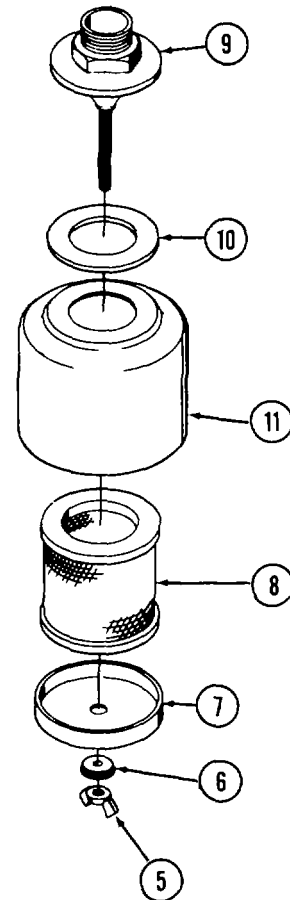
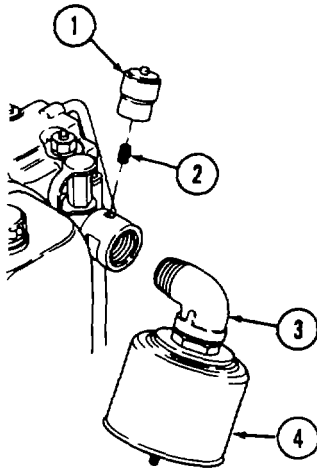
**REMOVAL:**

- 1 Unscrew restriction indicator (1) from nipple (2).
- 2 Unscrew air cleaner (3) from street elbow (4).
- 3 Unscrew street elbow (4) from engine.

DISASSEMBLY:

- 1 Remove wing nut (5) and sealing washer (6). Remove top (7) and air filter element (8).
- 2 Separate base connector (9), gasket (10) and rain hood (11).

4-15. REPLACE AIR FILTER ASSEMBLY (Continued)

REPAIR:

Replace all damage parts.

ASSEMBLY:

- 1 Place gasket (10) on rain hood (11). Insert base connector (9) into rain hood.
- 2 Insert air filter element (8) into rain hood. Place top (7) over air filter element.
- 3 Install sealing washer (6) and secure with wing nut (5).

INSTALLATION:

- 1 Install street elbow (4) on engine orienting elbow downward and toward rear of unit (pump end).
- 2 Install air cleaner (3) onto street elbow (4).
- 3 Install restriction indicator (1).

4-15. REPLACE AIR FILTER ASSEMBLY (Continued)

OPERATIONAL CHECK:

WARNING

Muffler and related components get hot enough during pump operation to cause severe burns. Avoid contact with muffler and related components during checks describe In this text.

Exposure to exhaust gases produces symptoms of headache, dizziness, loss of muscular control, drowsiness, or coma. Brain damage or death can result from severe exposure.

Fumes from engine become concentrated with poor ventilation. Operate engine In a ventilated area only. While running engine, be alert for fumes. Keep area ventilated. If someone Is overcome, expose to fresh air; keep warm and still; give artificial respiration If needed. Seek medical attention. Administer oxygen, if available.

GOOD VENTILATION IS THE BEST DEFENSE AGAINST EXHAUST POISONING.

- 1 Start engine (para 2-4) and observe air cleaner assembly and restriction indicator for looseness, rattles, or leaks. Tighten as required.
 - 2 If red band is visible in window of restriction indicator, shut down engine.
 - 3 Recheck installation and air filter. Reset restriction indicator.
 - 4 Restart engine. if red band is still visible, replace restriction indicator.
 - 5 Restart engine and check restriction indicator. If restriction indicator still shows red band, refer to direct support maintenance.
-

4-16. REPLACE COLD START ASSIST

This task covers: a. Removal b. Cleaning/Inspection c. Installation

INITIAL SETUP**Tools**

Tool Kit, General Mechanics Automotive
(Item 1, Appendix B)

Equipment Condition

Unit shut down and cool.

Materials/Parts

Dry cleaning solvent (Item 10, Appendix E)
Grease (Item 3, Appendix E)
Preformed packings

General Safety Instructions

Well-ventilated area required.

REMOVAL:

- 1 Remove cold start assist (1) and closing plug (2) and washer (4) from engine.
- 2 Remove and discard preformed packing (3).

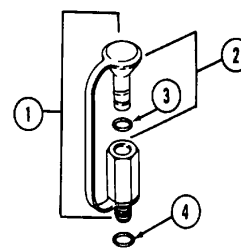
CLEANING/INSPECTION:**WARNING**

Dry cleaning solvent P-D-680 (safety or Stoddard's Solvent) is potentially dangerous. Avoid repeated and prolonged breathing of vapors and skin contact with the liquid. Do not use near open flame, arcing equipment, or other ignition sources. Always wear eye protection and protective clothing. The flash point of P-D-68 is 100°F to 138°F (38°C to 59°C).

Death or serious injury could occur if compressed air is directed against the skin. Do not use compressed air for cleaning or drying unless the pressure is/has been reduced to 30 psi (2.06 bar) or less. When working with compressed air always use chip guards, eye protection, and other personal equipment.

- 1 Clean cold start assist (1) and closing plug (2) with dry cleaning solvent and dry with low pressure compressed air.
- 2 Inspect cold start assist (1) and closing plug (2) for rust, corrosion, or other damage. Replace damaged components.

INSTALLATION:

- 1 Lubricate preformed packings (3) with grease and install into preformed packing groove of closing plug (2).
- 2 Install cold start assist (1) by sliding the looped end of the closing plug (2) and washer (4) over cold start assist and screwing it into the cylinder head.

4-17. REPLACE FUEL FILTER, FUEL PRESSURE LINE, HOSES AND FITTINGS

This task covers: a. Removal c. Installation
 b. Inspection

INITIAL SETUP**Tools**

Tool Kit, General Mechanics Automotive
 (Item 1, Appendix B)

General Safety Instructions

Unit must be cool. Fuel tank must be empty.
 Well-ventilated area.

Materials/Parts

Dry cleaning solvent (Item 10, Appendix E)
 Gasket

REMOVAL:**WARNING**

Death or serious injury could occur if fuel is not handled carefully. Use in a well-ventilated area away from open flame, arcing equipment, ignition sources, heaters, or excessive heat. Engine must be turned off and cool before refueling. Use proper refueling procedures and equipment to avoid spillage. Do not run engine near open fuel containers. Always store fuel in properly marked containers. **DO NOT SMOKE.**

CAUTION

As each fuel hose, connection, or connection port is removed, be sure to tape over or plug each open connection to prevent contaminants from entering the fuel system

- 1 Remove screw (1), spacers (2), and clamp (3).
- 2 Remove fuel filter (4) from fuel hose (5) (fuel lift pump to fuel filter).
- 3 Remove fuel filter (4) from fuel hose (6) (fuel filter to injection pump).
- 4 Discard fuel filter (4) and tape or plug fuel hoses (5 and 6).
- 5 Remove fuel hose (5) from fuel lift pump discharge fitting.

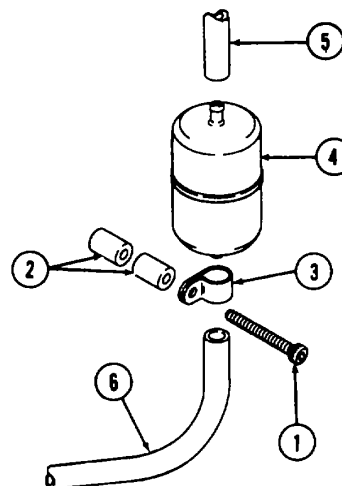

4-17. REPLACE FUEL FILTER, FUEL PRESSURE LINE, HOSES AND FITTINGS (Continued)

- 6 Remove screw (1) and clamps (2).
- 7 Remove fuel hose (3) from injection pump.
- 8 Remove fuel hose (4) from fuel lift pump (5).
- 9 Remove screw (6) and clamp (7).
- 10 Remove hose clamp (8) and fuel hose (4) from fuel tank.

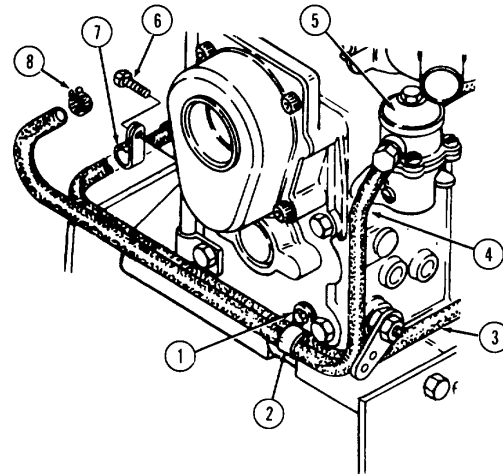

- 11 Remove fuel hose (9) (injection pump to double ring piece) from double ring piece (10) Tape or plug injection pump fitting.

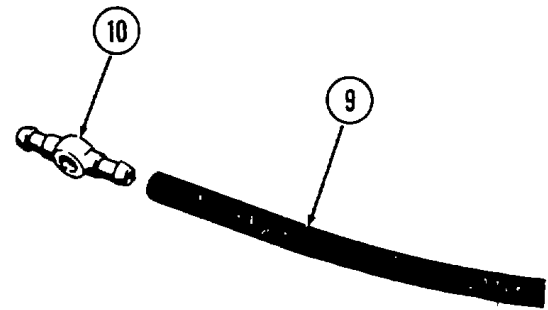

- 12 Remove fuel hose (11) (double ring piece to injector) from double ring piece (12). Tape or plug injector fitting.

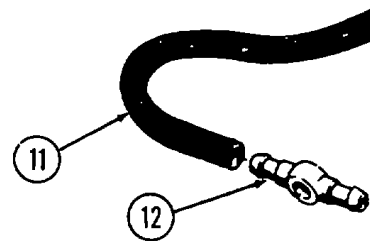

4-17. REPLACE FUEL FILTER, FUEL PRESSURE LINE, HOSES AND FITTINGS (Continued)

- 13 Remove fuel pressure line (1) from injector (2) and injection pump (3). Tape or plug fittings.

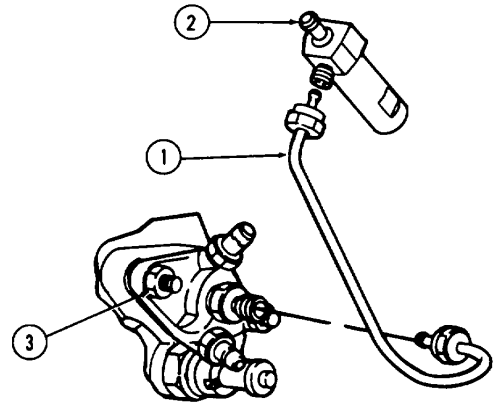

- 14 Remove non-return valve (1) and gasket (2). Discard gasket (2).

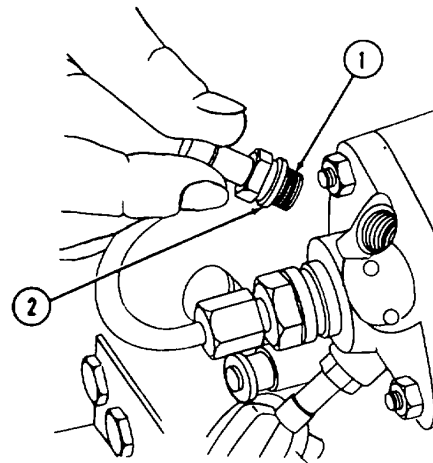
**INSPECTION:****WARNING**

Dry cleaning solvent P-D-680 (safety or Stoddard's Solvent) is potentially dangerous. Avoid repeated and prolonged breathing of vapors and skin contact with the liquid. Do not use near open flame, arcing equipment, or other ignition sources. Always wear eye protection and protective clothing. The flash point of P-D-68 \oplus is 100 \oplus F to 138 \oplus F (38 \oplus C to 59 \oplus C).

- 1 Inspect all fuel hoses for cracks, abrasions, or restrictions. Replace as necessary.
- 2 Inspect fuel pressure line (1) for damage, rust, corrosion, or restrictions. Replace if necessary.

4-17. REPLACE FUEL FILTER, FUEL PRESSURE LINE, HOSES AND FITTINGS (Continued)

- 3 Check non-return valve by shaking for free movement of internal valve ball. If necessary, clean with dry cleaning solvent. If internal valve ball does not have free movement, replace non-return valve.

INSTALLATION:

WARNING

Death or serious injury could occur if fuel is not handled carefully. Use in a well-ventilated area away from open flame, arcing equipment, ignition sources, heaters, or excessive heat. Engine must be turned off and cool before refueling. Always store fuel in properly marked containers. **DO NOT SMOKE.**

- 1 Install fuel pressure line (1) on injection pump (3) and injector (2).

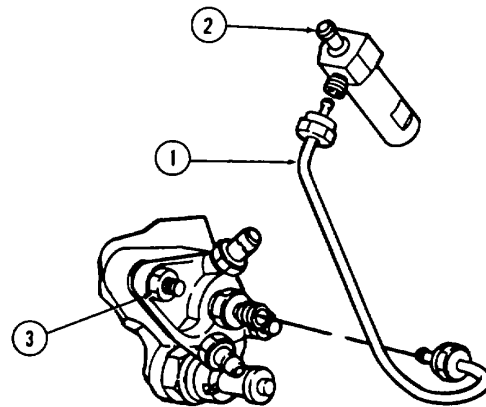

- 2 Install fuel hose (4) (double ring piece to injector) on double ring piece (5).

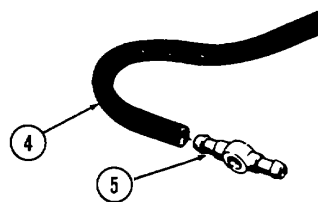

- 3 Install fuel hose (6) (injection pump to double ring piece) on double ring piece (7).

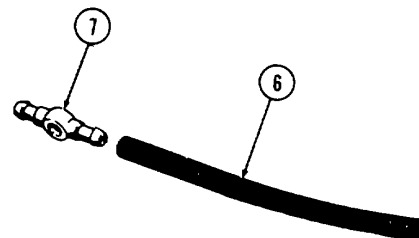

4-17. REPLACE FUEL FILTER, FUEL PRESSURE LINE, HOSES, AND FITTINGS (Continued)

- 4 Install clamp (1) on fuel hose (2) (fuel tank to fuel lift pump).
- 5 Install fuel hose (2) on fuel lift pump (7)-
- 6 Install fuel hose (8) on injection pump.
- 7 Install one clamp (4) with screw (6) on fuel hoses (2 and 8).
- 8 Install one clamp (3) with screw (5) on fuel hose (8).

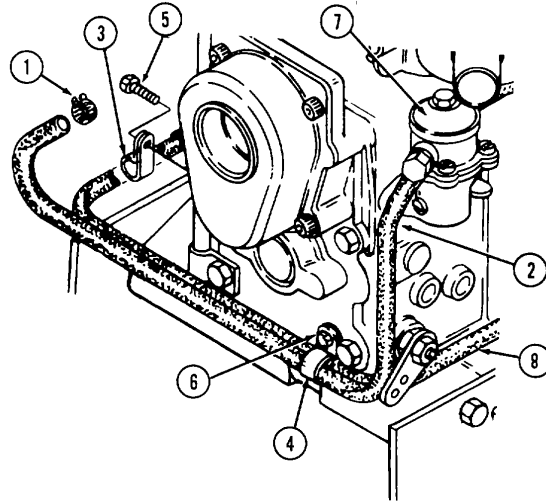

- 9 Install fuel hose (1) (fuel filter to fuel lift pump) and fuel hose (2) (injection pump to fuel filter) on a new fuel filter (3). Secure hoses with spacers (6), clamp (5), and screw (4).

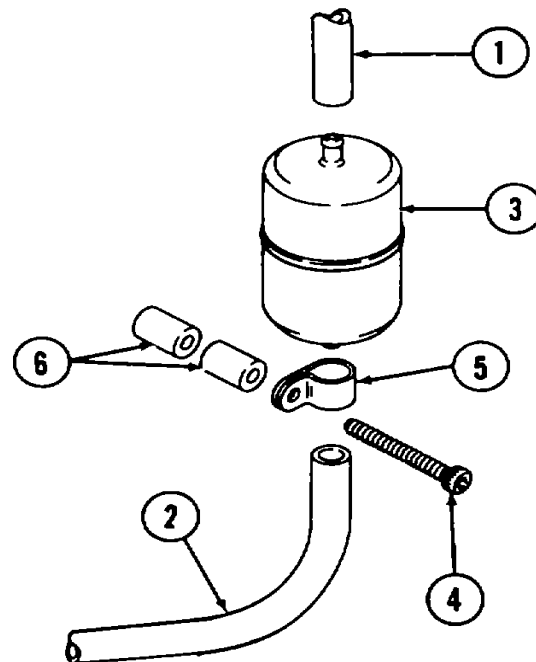

4-17. REPLACE FUEL FILTER, FUEL PRESSURE LINE, HOSES AND FITTINGS (Continued)

10 Install new gasket (2) and non-return vent valve (1).

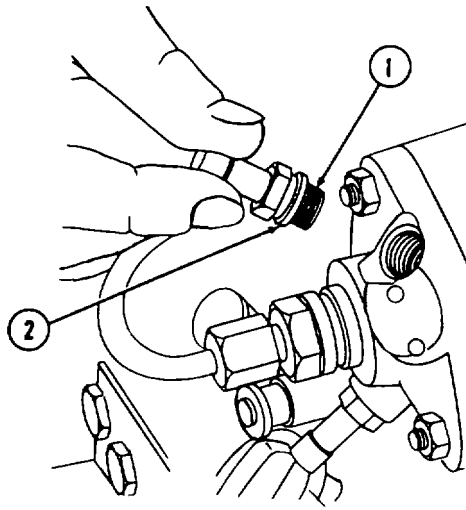

4-18. REPLACE FUEL LIFT PUMP

This task covers: a. Removal c. Operational Check
 b. Installation

INITIAL SETUP

Tools
 Tool Kit, General Mechanics Automotive
 (Item 1, Appendix B)

General Safety Instructions
 Well-ventilated area required.

Materials/Parts

**Equipment
 Condition
 Para**

Condition Description

Gasket

4-17 Fuel hoses removed from fuel lift pump.

REMOVAL:



Death or serious injury could occur if fuel is not handled carefully. Use in a well-ventilated area away from open flame, arcing equipment, ignition sources, heaters, or excessive heat. Engine must be turned off and cool before refueling. Use proper refueling procedures and equipment to avoid spillage. Do not run engine near open fuel containers. Always store fuel in properly marked containers. **DO NOT SMOKE.**

- 1 Remove two hexagon nuts (1) and flat washers (6).
- 2 Remove fuel lift pump (2) and gasket (3). Discard gasket.
- 3 Remove inlet and outlet ring pieces and banjo bolts (5).

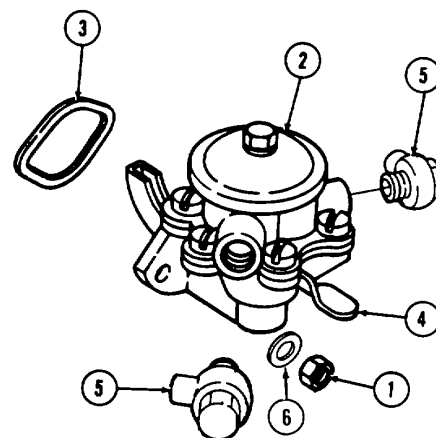

4-18. REPLACE FUEL LIFT PUMP (Continued)

INSTALLATION:

WARNING

Death or serious Injury could occur if fuel is not handled carefully. Use in a well-ventilated area away from open flame, arcing equipment, ignition sources, heaters, or excessive heat. Engine must be turned off and cool before refueling. Use proper refueling procedures and equipment to avoid spillage. Do not run engine near open fuel containers. Always store fuel in properly marked containers. **DO NOT SMOKE.**

- 1 Install new gasket (3) and fuel lift pump (2).
- 2 Install two hexagon nuts (1) and flat washers (6).
- 3 Install inlet and outlet ring pieces and banjo bolts (5).
- 4 Install hoses onto outlet ring pieces (5).

OPERATIONAL CHECK:

NOTE

The fuel lift pump is cam driven. If high point of camshaft cam is in contact with fuel lift pump cam lever, fuel system cannot be primed using primer lever.

- 1 Check that fuel lift pump is operational by operating primer lever (4).
 - 2 Engage hand crank in gear housing and rotate clockwise to change camshaft position.
 - 3 Operate primer lever (4) on fuel lift pump and check for pumping action. If pumping action is not felt, continue to rotate hand crank until cam position allows hand priming.
-

4-19. REPLACE FUEL TANK

This task covers: a. Removal
 b. Installation

INITIAL SETUP

Tools

Tool Kit, General Mechanics Automotive
 (Item 1, Appendix B)

General Safety Instructions

Well-ventilated area required.

Materials/Parts

Hexagon lock nuts

**Equipment
 Condition**

Para
 4-17

Condition Description

Fuel hoses removed from fuel tank.

REMOVAL:



Death or serious injury could occur if fuel is not handled carefully. Use in a well-ventilated area away from open flame, arcing equipment, ignition sources, heaters, or excessive heat. Engine must be turned off and cool before refueling. Always store fuel in properly marked containers. **DO NOT SMOKE.**

- 1 Remove two long hexagon socket head screws (1), two short hexagon socket head screws (2), four spacers (3), two tube spacers (4) and two hexagon lock nuts (5). Discard the hexagon lock nuts.
- 2 Remove fuel tank (6) from engine.

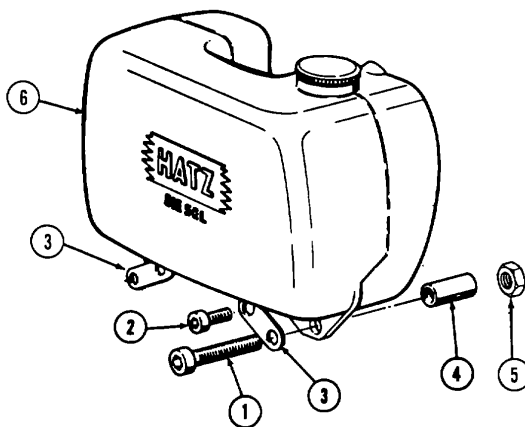

4-19. REPLACE FUEL TANK (Continued)

INSTALLATION:

WARNING

Death or serious injury could occur if fuel is not handled carefully. Use in a well-ventilated area away from open flame, arcing equipment, ignition sources, heaters, or excessive heat. Engine must be turned off and cool before refueling. Always store fuel in properly marked containers. **DO NOT SMOKE.**

- 1 Position fuel tank (6) on engine.
 - 2 Install two tube spacers (4) between fuel tank (6) and engine. Install four spacers (3), two short hexagon socket head screws (2), two long hexagon socket head screws (1) and new hexagon lock nuts (5). Tighten screws securely.
-

4-20. REPLACE MUFFLER

This task covers: a. Removal c. Operational Check
 b. Installation

INITIAL SETUP**Tools**

Tool Kit, General Mechanics Automotive
 (Item 1, Appendix B)

General Safety Instructions

Unit must be cool.

Materials/Parts

Gasket

REMOVAL:**WARNING**

Handling a hot muffler can cause severe burns. Allow unit to cool before handling.

- 1 Remove two screws (1) and two washers (2).
- 2 Remove heat shield (3).
- 3 Remove two screws (4) and two washers (5).
- 4 Remove cleanout plug (6).
- 5 Remove protective screen (7).
- 6 Remove two nuts (8).
- 7 Remove muffler (9) and gasket (10). Discard gasket (10).

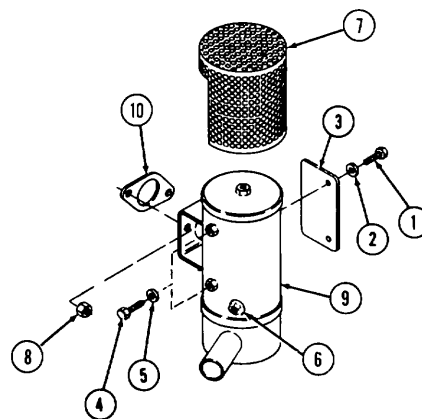
**INSPECTION:**

- 1 Inspect screws, nuts, washers, heat shield, protective screen, and muffler for rust corrosion, or other damage. Replace if necessary.
- 2 Tap on muffler to drain spark trap of accumulated particles. If necessary, use a wire brush to clean spark trap.

4-20. REPLACE MUFFLER (Continued)**INSTALLATION:**

- 1 Install new gasket (10) and muffler (9).
- 2 Install two nuts (8). Tighten securely.
- 3 Install protective screen (7).
- 4 Install cleanout plug (6).
- 5 Install two washers (5) and two screws (4).
- 6 Install heat shield (3).
- 7 Install two washers (2) and two screws (1).

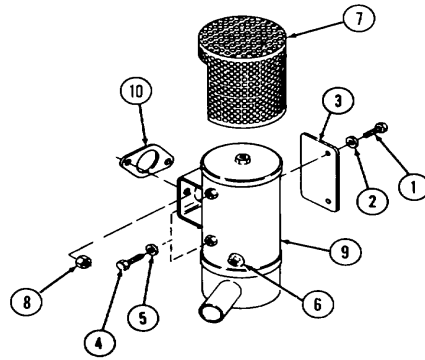
**OPERATIONAL CHECK:****WARNING**

Touching exhaust system during test can cause severe burns.

Exposure to exhaust gases produces symptoms of headache, dizziness, loss of muscular control, drowsiness, or coma. Brain damage or death can result from severe exposure.

Fumes from engine become concentrated with poor ventilation. Operate engine in a ventilated area only.

While running engine, be alert for fumes. Keep area ventilated. If someone is overcome, expose to fresh air; keep warm and still; give artificial respiration if needed. Seek medical attention. Administer oxygen, if available.

GOOD VENTILATION IS THE BEST DEFENSE AGAINST EXHAUST POISONING.

Start engine and observe muffler (9) for leaks and/or rattles. Tighten screws (1 and 4) and nuts (8) as necessary to prevent rattles. If muffler leaks, replace it.

4-21. REPLACE/ADJUST THROTTLE CONTROL

This task covers: a. Removal c. Adjustments
 b. Installation

INITIAL SETUP

Tools

Tool Kit, General Mechanics Automotive
 (Item 1, Appendix B)

General Safety Instructions

Engine shut down.

REMOVAL:

- 1 Remove hexagon nuts (1 and 2). Remove throttle linkage assembly (3, 4, 5, 6 and 7).
- 2 Remove two hexagon jam nuts (8), flat washer (9), wave washer (10), hand lever (11), lever (12) and screw (13).
- 3 Remove two hexagon socket head screws (14) and four flat washers (15), and remove console (16) with attached stops (17).

INSTALLATION:

- 1 Install hexagon screw (13) through console (16), lever (12), hand lever (11), wave washer (10), flat washer (9) and two hexagon jam nuts (8). Hand tighten the hexagon jam nuts.
- 2 Install flat washers (15) and console (16), and secure with two hexagon socket head screws (14). Tighten the screws securely.
- 3 Engage tang on hand lever (11) with notch on lever (12) and tighten two hexagon jam nuts (8).
- 4 Install throttle linkage assembly (3, 4, 5, 6 and 7) joint ends into lever (12) and lever (18). Secure with hexagon nuts (1 and 2) fully tightened.

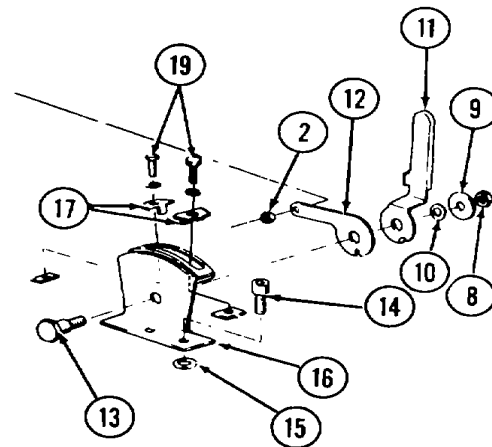
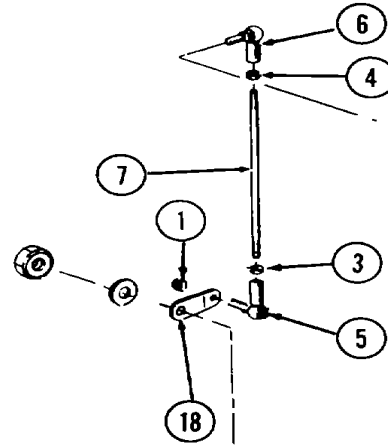

4-21. REPLACE/ADJUST THROTTLE CONTROL ADJUSTMENTS:

ADJUSTMENTS:

- 1 IDLE ADJUSTMENT. With engine running, loosen hexagon screw (19) and slide stop (17) toward fuel lift pump side of engine. Move hand lever (11) to desired idle speed. Slide stop (17) against hand lever (11) and tighten hexagon screw (19).

 - 2 TOP SPEED ADJUSTMENT. With engine running , loosen second hexagon screw (19) located closest to injection pump. Slide second stop (17) toward fuel lift pump side of engine. Move hand lever (11) to engine top speed. Slide second stop (17) against hand lever (11) and tighten screw (19).

 - 3 If idle or top speed of engine cannot be obtained, loosen nuts (3 and 4) and turn adjusting screw (7) to increase or decrease travel of hand lever (11). Tighten nuts (3 and 4) after adjusting.
-

4-22. ADJUST CYLINDER HEAD AND VALVE ASSEMBLY

This task covers: Adjustments

INITIAL SETUP

Tools

Tool Kit, General Mechanics Automotive
(Item 1, Appendix B)

Equipment Condition

Engine shut down and cool-

Materials/Parts

Gasket

General Safety Instructions

Well-ventilated area required.

ADJUSTMENT:

- 1 Remove hexagon head screw (1), two copper washers (7) and pipe clip (2).
- 2 Remove two hexagon nuts (3) and two wave washers (4).
- 3 Lift cylinder head cover (5) from cylinder head.
- 4 Remove and discard gasket (6).

- 5 Adjust tappet clearance.
 - a. Put decompression lever (1) in position 0
 - b. Crank engine clockwise when viewed from throttle control lever until compression resistance can be felt.

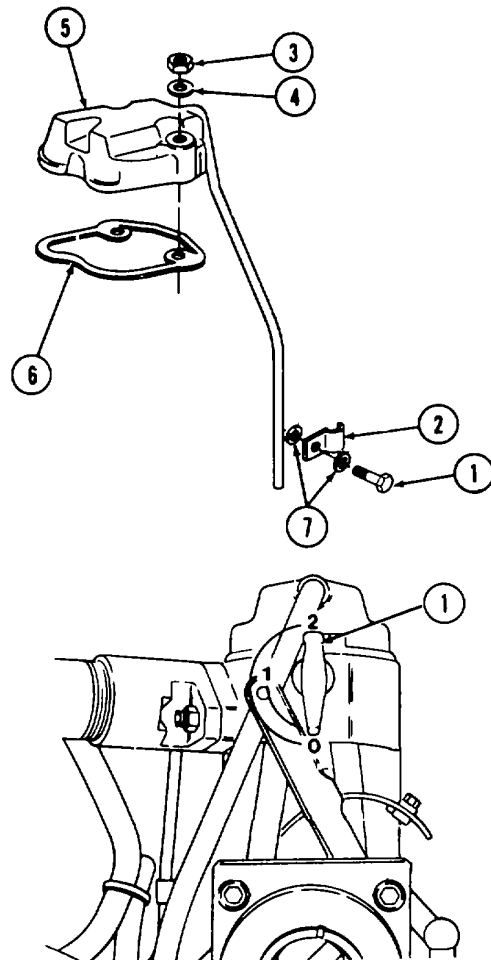

4-22. ADJUST CYLINDER HEAD AND VALVE ASSEMBLY (Continued)

- c. Check clearance between exhaust rocker and valve stem with a feeler gauge. Tappet clearance cold should be 0.004 inch (0.10 mm). To correct clearance loosen nut (2).
- d. Adjust screw (3) with screwdriver until feeler gauge can be pulled between rocker and valve stem with very slight resistance after nut (2) has been tightened.
- e. Repeat steps a. through d. for intake rocker and valve stem if necessary.

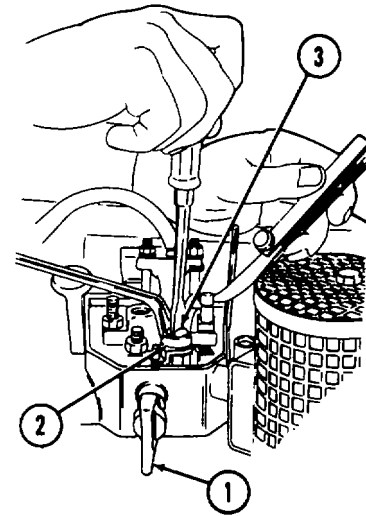

- 6 Install new gasket (6) on cylinder head.
- 7 Install cylinder head cover (5) on new gasket (6).
- 8 Install two wave washers (4) and hexagon nuts (3). Tighten securely.

Note

Insure that copper washers are installed on both sides of the pipe clip to prevent oil leaks.

- 9 Install pipe clip (2), copper washers (7) and hexagon head screw (1).

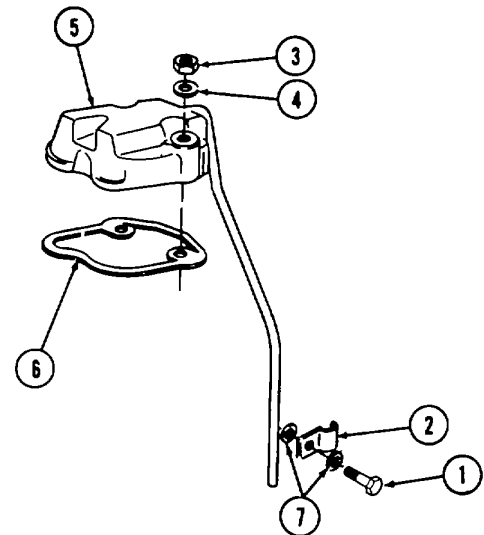

Section VI. PREPARATION FOR STORAGE OR SHIPMENT**4-23. GENERAL**

This section provides instructions for preparing the centrifugal pump unit for short term and intermediate storage or shipment.

4-24. ADMINISTRATIVE STORAGE

Administrative storage shall be in accordance with AR 750-1.

NOTE

When centrifugal pump unit is taken out of service, take special precautions to protect the interior and exterior of the unit from rust accumulation and corrosion.

4-25. SHORT TERM STORAGE (30 days or less)**WARNING**

Death or serious injury could occur if fuel is not handled carefully. Use in a well-ventilated area away from open flame, arcing equipment, ignition sources, heaters, or excessive heat. Engine must be turned off and cool before refueling. Use proper refueling procedures and equipment to avoid spillage. Do not run engine near open fuel containers. Always store fuel in properly marked containers. **DO NOT SMOKE.**

a. Fill fuel tank with diesel fuel. Connect centrifugal pump unit to a flammable liquid supply. Prime pump and operate the engine for 2 minutes.

NOTE

Do not drain the fuel system after this run. Remove flammable liquid supply after this run.

4-25. SHORT TERM STORAGE (30 days or less) (Continued)

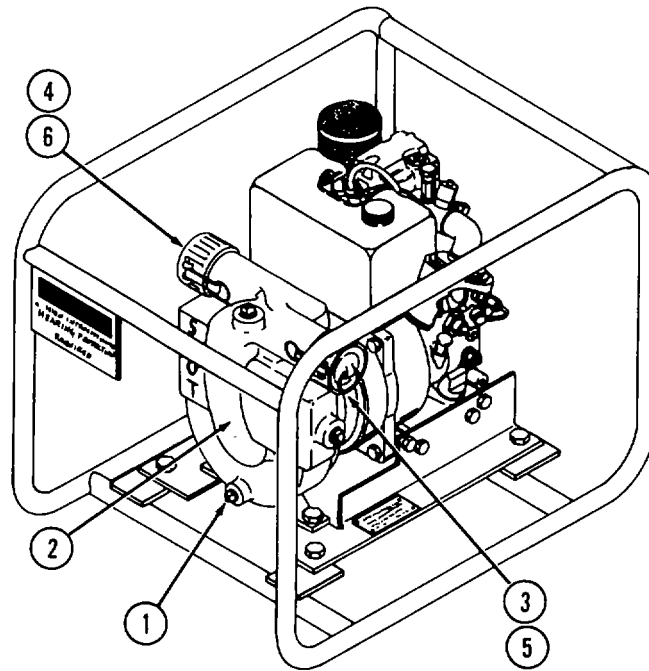

- b. Remove suction hose from quick disconnect coupling half (3) (intake).
- c. Remove discharge hose from quick disconnect coupling half (4) (discharge).
- d. Remove pipe plug (1) and drain pump housing (2). Replace pipe plug (1).
- e. Clean intake and discharge quick disconnect coupling halves using wet cloth.
- f. Install dust plug (5) and dust cap (6).

4-26. INTERMEDIATE TERM STORAGE (more than 30 days)

- a. Connect centrifugal pump to a flammable liquid supply. Prime pump, start engine, and allow to operate for 10 to 12 minutes or until normal operating temperature is reached. Shut down engine.
- b. Drain crankcase oil. Then fill crankcase to proper level using preservative lubricating oil, Item 7, Appendix E.

4-26. INTERMEDIATE TERM STORAGE (more than 30 days) (Continued)

WARNING

Death or serious injury could occur if fuel is not handled carefully. Use in a well-ventilated area away from open flame, arcing equipment, ignition sources, heaters, or excessive heat. Engine must be turned off and cool before refueling. Always store fuel in properly marked containers. **DO NOT SMOKE.**

- c. Remove fuel tank cap (1) and hose (2) connected to fuel lift pump. Collect fuel in a suitable metal container.
- d. Replace fuel filter (para 4-17).
- e. Reconnect hose to and pour approximately one pint of preservative oil, Item 8, Appendix E, in fuel tank.
- f. Start engine and allow to operate for not less than 5 to 7 minutes. Shut down engine.

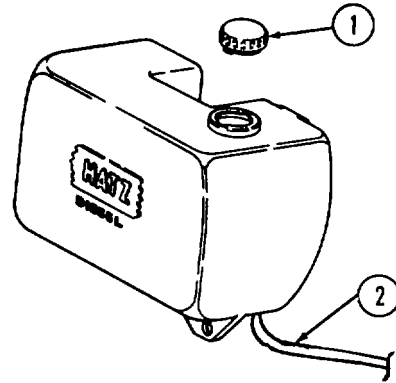

- g. Service air cleaner in accordance with paragraph 3-4.
- h. Remove pipe plug (1) and drain pump housing (2). Replace pipe plug (1).
- i. Remove suction hose from quick disconnect coupling half (3) (intake).
- j. Remove discharge hose from quick disconnect coupling half (4).
- k. Install dust plug (6) and dust cap (7).
- l. Coat all accessible surfaces with preservative oil, Item 7, Appendix E.
- m. Remove pipe plug (5) and pour approximately one quart of preservative oil, Item 8, Appendix E, into pump housing (2). Replace pipe plug (5).

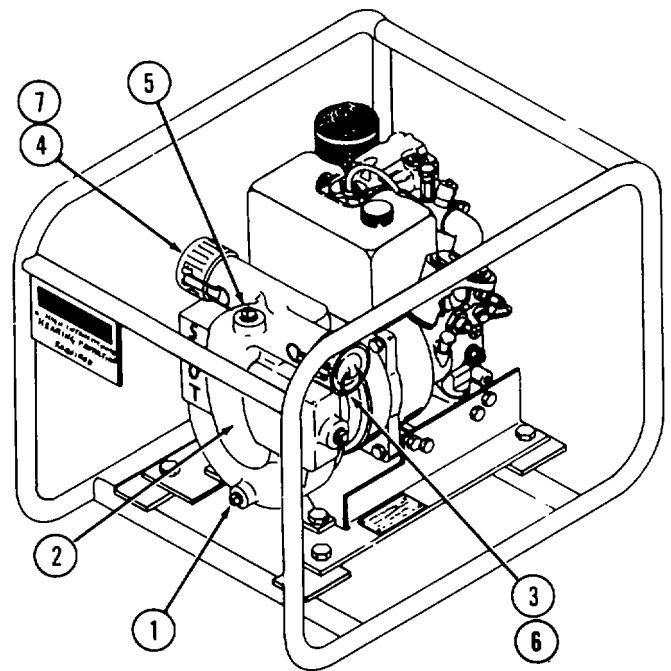

4-27. SHIPMENT

- a. Use shipping plugs, closures, or sealing tape to cover all openings in the pump and engine.
- b. Attach to the centrifugal pump unit all forms, tags, and records applicable to the unit.

**CHAPTER 5
DIRECT SUPPORT MAINTENANCE INSTRUCTIONS**

Section I. TROUBLESHOOTING

5-1. TROUBLESHOOTING

a. Table 5-1 contains troubleshooting information for locating and correcting most of the operating troubles which are the responsibility of direct support maintenance. Each malfunction for an individual component, unit, or system is followed by a list of tests or inspections which will help you to determine probable causes and corrective actions to take. Perform the tests/inspections and corrective actions in the order listed.

b. This manual cannot list all malfunctions that may occur, nor all tests or inspections and corrective actions. If a malfunction is not listed or is not corrected by listed corrective actions, notify your supervisor.

c. Only those functions within the scope of direct support maintenance are listed. For troubleshooting procedures within the scope of the operator/crew maintenance, refer to table 3-1. For troubleshooting procedures within the scope of unit maintenance, refer to table 4-2.

5-2. SYMPTOM INDEX

Refer to the symptom Index below. Locate the malfunction which is the same, or most nearly the same, as the trouble you are having with the centrifugal pump unit. The Symptom Index lists the first page of the troubleshooting information for that malfunction. Follow the steps one by one, and perform the corrective actions listed.

Symptom Index

Malfunction Number	Description	Page
1	Engine cranks but fails to start	5-2
2	Engine starts but runs unevenly, stalls, or surges	5-2
3	Engine stops running or produces black, white, or gray smoke	5-2
4	Engine consumes excessive lube oil	5-2

Table 5-1. Direct Support Troubleshooting

MALFUNCTION	TEST OR INSPECTION	CORRECTIVE ACTION
1. ENGINE CRANKS BUT FAILS TO START		
Step 1.	Check for faulty fuel lift pump.	Repair fuel lift pump (para 5-6).
Step 2.	Check for faulty injector. Remove and test injector (para 5-7).	Repair or replace faulty injector (para 5-7).
Step 3.	Check that compression is 280 psi minimum.	Replace engine (para 5-5).
Step 4.	Check for loose cylinder head.	If loose, tighten four hexagon nuts to 37 foot-pounds (6.5 m-kg) (para 5-10).
2. ENGINE STARTS BUT RUNS UNEVENLY, STALLS, OR SURGES		
Step 1.	Check for air in the fuel system.	Service injector (para 5-7).
Step 2.	Check for faulty injector. Remove and test injector (para 5-7).	Repair or replace faulty injector (para 5-7).
3. ENGINE STOPS RUNNING OR PRODUCES BLACK, WHITE, OR GRAY SMOKE		
Step 1.	Check for faulty fuel lift pump.	Repair fuel lift pump (para 5-6).
Step 2.	Check for faulty injector. Remove and test injector (para 5-7).	Repair or replace faulty injector (para 5-7).
4. ENGINE CONSUMES EXCESS LUBE OIL		
Step 1.	Check for oil leaks on bottom of engine.	Tighten screws on cover located on bottom of engine.

Section II. MAINTENANCE PROCEDURES

INDEX

	Para		Para
Crank assembly gears	5-9	Injection pump	5-8
Cylinder	5-11	Injector	5-7
Cylinder head and valve assembly	5-10	Lift pump	5-6
Engine assembly	5-5	Piston	5-12
Flywheel	5-13	Pump housing	5-4
Frame assembly	5-14		

5-3. GENERAL INSTRUCTIONS

Maintenance instructions in this section will list resources required, personnel required, and equipment condition for the start of the procedure. Note the following:

- Resources required are not listed unless they apply to the procedure.
- Personnel required are listed only if the task requires more than one. If PERSONNEL is not listed, it means one person can do the task.
- The normal standard equipment condition to start a maintenance task is engine stopped. EQUIPMENT CONDITION is not listed unless some other condition is required.

5-4. REPAIR PUMP HOUSING

This task covers: Repair/Cleaning

INITIAL SETUP

Tools

Tool Kit, General Mechanics Automotive
(Item 1, Appendix B)

Equipment Condition Para

4-13

Condition Description

Pump housing assembly removed.

Materials/Parts

Dry cleaning solvent (Item 10, Appendix E)
Zinc chromate primer coating (item 9, Appendix E)

General Safety Instructions

Well-ventilated area required.

REPAIR/CLEANING:

- 1 Remove each insert (1) from pump housing(2) by using a scribe or other pointed instrument. Pry the last thread of insert into center of tapped hole. Grasp thread with needle-nosed pliers and remove damaged insert by threading out of hole.

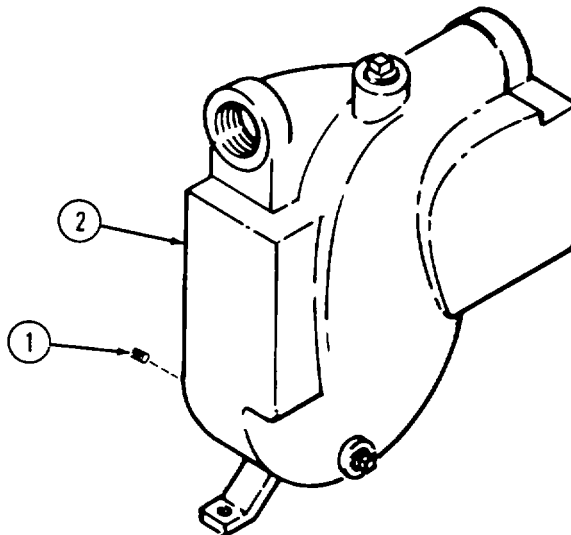

5-4. REPAIR PUMP HOUSING (Continued)

- 2 Chase threaded hole using appropriate size tap.

WARNING

Dry cleaning solvent P-D-680 (safety or Stoddard's Solvent) is potentially dangerous. Avoid repeated and prolonged breathing of vapors and skin contact with the liquid. Do not use near open flame, arcing equipment, or other ignition sources. Always wear eye protection and protective clothing. The flash point of P-D-680 is 100°F to 138°F (38°C to 59°C).

Death or serious injury could occur if compressed air is directed against the skin. Do not use compressed air for cleaning or drying unless the pressure is/has been reduced to 30 psi (2.06 bar) or less. When working with compressed air always use chip guards, eye protection, and other personal equipment.

- 3 Using dry cleaning solvent and a stiff-bristled brush, clean threaded hole thoroughly.
 - 4 Using clean compressed air at 30 psi (2.06 bar) maximum discharge pressure, blow out threaded hole to make sure that all solvent has been removed and no particles are left in the hole.
 - 5 Coat new insert (1) with zinc chromate primer coating.
 - 6 Insert each new insert to a depth of 1 to 1.5 pitches below the top surface of the tapped hole in the pump housing (2). Wipe off excess primer.
 - 7 Remove drive tang from installed insert.
-

5-5. Replace engine assembly

This task covers: a. Removal b. Installation

INITIAL SETUP

Tools

Tool Kit, General Mechanics Automotive
(Item 1, Appendix B)

General Safety Instructions

Hoisting equipment shall be used only by authorized personnel.

Materials/Parts

Lock washers

Equipment Condition Para

Condition Description

4-13

Pump housing assembly removed.

4-15

Air filter assembly removed.

REMOVAL:

WARNING

Death or serious injury could occur if unauthorized or unnecessary personnel are in the hoisting area. Permit only personnel actually engaged in the hoisting operation to be near the unit and hoisting equipment. All instructions for the hoisting operations must come from one authorized person.

Injury or damage to unit could occur from improper hoisting. Hoist the load slowly to avoid tearing out lifting strap, slipping slings, or load shift. Do not jerk the load or swing it from side-to-side when hoisting. This places additional stress on hoisting components which can cause failure and loss of load. Be sure hoisting equipment is on solid footing and is suitable for the size of the load. Watch boom angle and overhead clearance when hoisting.

CAUTION

Engine will be damaged if set on cover at bottom of engine. Provide adequate blocking to support engine after removal.

- 1 Position a suitable lifting device over engine assembly. Attach to lifting strap (1).
- 2 Put tension on slings. Make sure engine is properly supported.
- 3 Remove four hexagon screws (2) and four lock washers (3) from each engine bracket (4). Remove engine assembly (5) from frame.

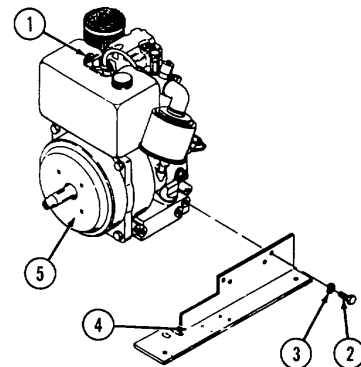

5-5. REPLACE ENGINE ASSEMBLY (Continued)

- 4 Lift engine assembly (5) and lower onto blocks on a stable, level work platform.

INSTALLATION:**WARNING**

Death or serious injury could occur if unauthorized or unnecessary personnel are in the hoisting area. Permit only personnel actually engaged in the hoisting operation to be near the unit and hoisting equipment. All instructions for the hoisting operations must come from one authorized person.

Injury or damage to unit could occur from improper hoisting. Hoist the load slowly to avoid tearing out lifting strap, slipping slings, or load shift. Do not jerk the load or swing it from side to side-to-side when hoisting. This places additional stress on hoisting components which can cause failure and loss of load. Be sure hoisting equipment is on solid footing and is suitable for the size of the load. Watch boom angle and overhead clearance when hoisting.

- 1 Attach lifting equipment. Lift and carefully lower engine assembly (5). Align mounting holes on engine and engine brackets.
 - 2 Install four hexagon screws (2) and four new lock washers (3) on each engine bracket (4). Tighten securely.
-

5-6. REPAIR FUEL LIFT PUMP

This task covers: a. Disassembly c. Assembly
 b. Repair

INITIAL SETUP

Tools

Tool Kit, General Mechanics Automotive
 (Item 1, Appendix B)

**Equipment
 Condition
 Para**

Condition Description

Materials/Parts

Dry cleaning solvent (item 10, Appendix E)
 Lubricating oil (Item 6, Appendix E)
 Gasket
 Diaphragm

4-18

Fuel lift pump removed from engine.

General Safety Instructions

Well-ventilated area required.

DISASSEMBLY:



Do not scratch or mar mating surfaces of pump body or cover. The fuel lift pump may leak or otherwise malfunction after reassembly.

- 1 Remove screw (1), gasket (2), and cover (3).
- 2 Remove and discard gasket (4).
- 3 Remove fuel screen(5).
- 4 Remove six screws (6).
- 5 Remove upper pump chamber (7).
- 6 Remove diaphragm (8) from pump body (9) and discard.

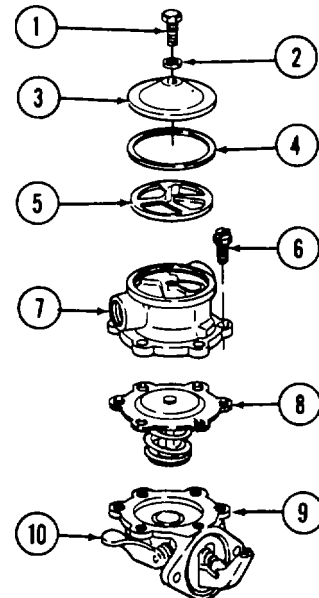

5-6. REPAIR FUEL LIFT PUMP (Continued)

REPAIR:

WARNING

Dry cleaning solvent P-D-680 (safety or Stoddard's Solvent) is potentially dangerous. Avoid repeated and prolonged breathing of vapors and skin contact with the liquid. Do not use near open flame, arcing equipment, or other Ignition sources. Always wear eye protection and protective clothing. The flash point of P-D-680 is 100°F to 138°F (38°C to 59°C).

Death or serious injury could occur if compressed air is directed against the skin. Do not use compressed air for cleaning or drying unless the pressure is/has been reduced to 30 psi (2.06 bar) or less. When working with compressed air always use chip guards, eye protection, and other personal equipment.

- 1 Clean all parts except gasket (4) with dry cleaning solvent and dry with low-pressure compressed air.
- 2 Inspect mating surface of cover (3) and pump body (9) parts for roughness or other damage. Scratches or other damage may result in pressure leaks.
- 3 Check for wear at contact areas. Replace pump body (9) or cover (3) if worn.
- 4 Inspect all parts for score marks and burrs. Parts must fit together tightly.
- 5 If parts are not repairable, replace.

ASSEMBLY:

CAUTION

Do not scratch or mar mating surfaces of pump body or cover. The fuel lift pump may leak or otherwise malfunction after reassembly.

- 1 Install new diaphragm (8) into pump body (9).
- 2 Install upper pump chamber (7) on diaphragm (8).
- 3 Install six screws (6) finger tight. Move fuel primer lever (10) on pump body (9) to compress diaphragm spring. Tighten the six screws.
- 4 Install fuel screen (5).
- 5 Lubricate gasket (4) with lubricating oil and install.
- 6 Install screw (1), gasket (2), and cover (3).

5-7. REPLACE INJECTOR

This task covers: a. Removal c. Installation
 b. Testing

INITIAL SETUP

Tools

Tool Kit, General Mechanics Automotive
 (Item 1, Appendix B)

Testing Device For Injection Equipment
 (item 3, Appendix B)

**Equipment
 Condition
 Para**

4-17

Condition Description

Fuel pressure line removed.

General Safety Instructions

Well-ventilated area required.

Materials/Parts

Dry cleaning solvent (Item 10, Appendix E)
 Grease (Item 3, Appendix E)
 Joint washer

REMOVAL:



Death or serious injury could occur if fuel is not handled carefully. Use in a well-ventilated area away from open flame, arcing equipment, ignition sources, heaters, or excessive heat. Engine must be turned off and cool before refueling. Always store fuel in properly marked containers. DO NOT SMOKE.



The fuel injection system is extremely intricate and complex. All possible care should be taken in the removal inspection, testing, and reassembly of these components. While handling the fuel injector, be extremely careful not to touch the nozzle or the pin assembly on the nozzle end.

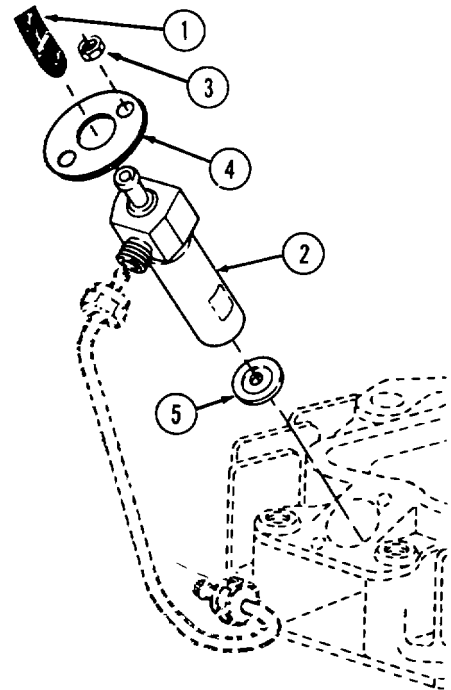

- 1 Remove fuel return line (1) from injector (2).
- 2 Remove hexagon nuts (3) and hold down clamp (4).
- 3 Remove injector (2) and joint washer (5) from cylinder head. Discard joint washer.

5-7. REPLACE INJECTOR (Continued)

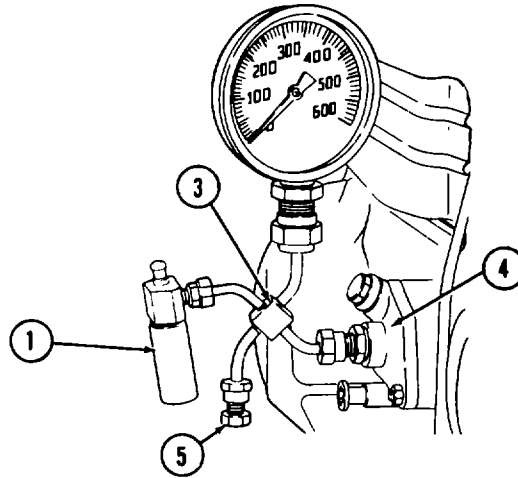
TESTING:

- 1 Visually inspect injector (1) for scoring or burning. Inspect to see if injector is bent, cracked, or damaged. If injector is damaged, replace it.

NOTE

Loosen the pressure gauge connection, and crank the engine until trapped air is removed from the system.

- 2 Connect testing device (3) to injector pump (4) and injector (1). Make sure side connection (5) is tightly locked.

WARNING

Death or serious injury could occur if fuel is not handled carefully. Use in a well-ventilated area away from open flame, arcing equipment, ignition sources, heaters, or excessive heat. Engine must be turned off and cool before refueling. Always store fuel in properly marked containers. DO NOT SMOKE.

Serious injury could result from injector spray. Keep hands away from fuel spray.

NOTE

Prior to testing injector, make sure throttle control hand lever is all the way to the left past stop.

- 3 Crank engine by hand. As the engine is cranked, read fuel injection pressure on the gauge and check fuel spray pattern from injector. Injection pressure should be 1958 to 2074 psi (135 to 143 bar). Fuel should spray out in an even spray pattern. If spray pattern does not conform to above, replace injector. If injector nozzle drips fuel before or after it has reached recommended injection pressure, replace injector.

5-7. REPLACE INJECTOR (Continued)

INSTALLATION:

CAUTION

The fuel injection system is extremely intricate and complex. All possible care should be taken in the removal, inspection, testing, and reassembly of these components. While handling the fuel injector, be extremely careful not to touch the nozzle or the pin assembly on the nozzle end.

- 1 Be certain injector seat in cylinder head is clean. Lightly coat joint washer (5) with grease and install on nozzle end of injector (2). Make sure outside beveled edge of new joint washer points toward cylinder head.
- 2 Carefully install injector (2) into injector bore in cylinder head. Make sure not to damage nozzle needle. Install hold down clamp (4) over injector. Secure with two hexagon nuts (3). Tighten to 7 foot-pounds (10 N•m).
- 3 Install fuel return line (2) onto injector (2).

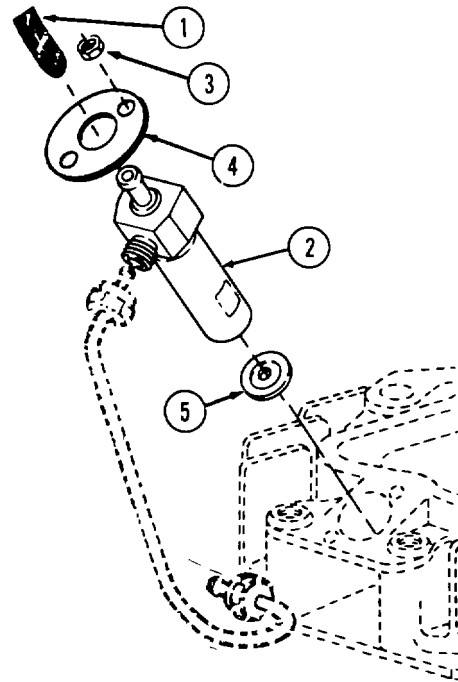

5-8. TEST INJECTION PUMP

This task covers: a. Test

INITIAL SETUP

Tools

Tool Kit, General Mechanics Automotive (Item 1, Appendix B)

Testing Device For Injection Equipment (Item 3, Appendix B)

Dial Gauge (Item 3, Appendix B)

Socket Wrench, 30 MM (Item 3, Appendix B)

Special Wrench (Item 3, Appendix B)

Extra Fuel Device (Item 3, Appendix B)

Materials/Parts

Dry cleaning solvent (Item 10, Appendix E)
Lubricating oil (Item 6, Appendix E)

Equipment Condition Para

Condition Description

4-13 Pump housing assembly removed.

4-17 Fuel hose and pressure line removed.

General Safety Instructions

Well-ventilated area required.

TEST:

NOTE

Perform this test before removal of injection pump and after installation.



Death or serious injury could occur if fuel is not handled carefully. Use in a well-ventilated area away from open flame, arcing equipment, ignition sources, heaters, or excessive heat. Engine must be turned off and cool before refueling. Always store fuel in properly marked containers. **DO NOT SMOKE.**

- 1 Connect fuel hose (1) from lift pump to injection pump (4).
- 2 Make sure the extra fuel device button is not pulled to the extended position. If the button is extended, move the throttle control hand lever to the right and then return the lever to the left to reset the extra fuel button.

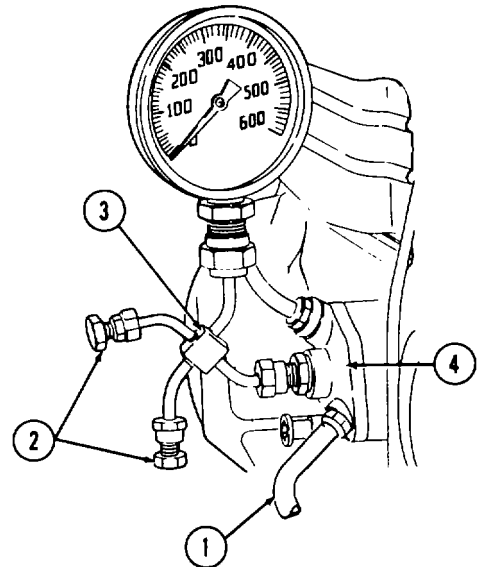

5-8. TEST INJECTION PUMP (Continued)

- 3 Connect testing device(3) to injection pump (4). Make sure side connections (2) are tightly locked.
- 4 Loosen the pressure gauge connection, and crank the engine until trapped air is removed from the system.
- 5 Tighten pressure gauge connection.



The pressure gauge can be damaged if the engine is cranked beyond the gauge limits. Failure to heed this caution can damage equipment.

- 6 Slowly crank engine by hand. As the engine is cranked, read fuel injection pressure on the gauge. Injection pressure should be 4351 to 5076 psi (300 to 350 bar). Stop cranking engine and observe whether pressure is maintained. If pressure drops below 3650 psi (250 bar) within 10 to 15 seconds, then injection pump not in working order.
 - 7 Remove testing device (3).
-

5-9. REPLACE CRANK ASSEMBLY GEARS

This task covers: a. Removal c. Installation
b. Cleaning/Inspection

INITIAL SETUP**Tools**

Tool Kit, General Mechanics Automotive
(Item 1, Appendix B)

General Safety Instructions

Well-ventilated area required.

Materials/Parts

Dry cleaning solvent (Item 10, Appendix E)
Grease (Item 3, Appendix E)
Grease (Item 4, Appendix E)
Gasket
Lock washer

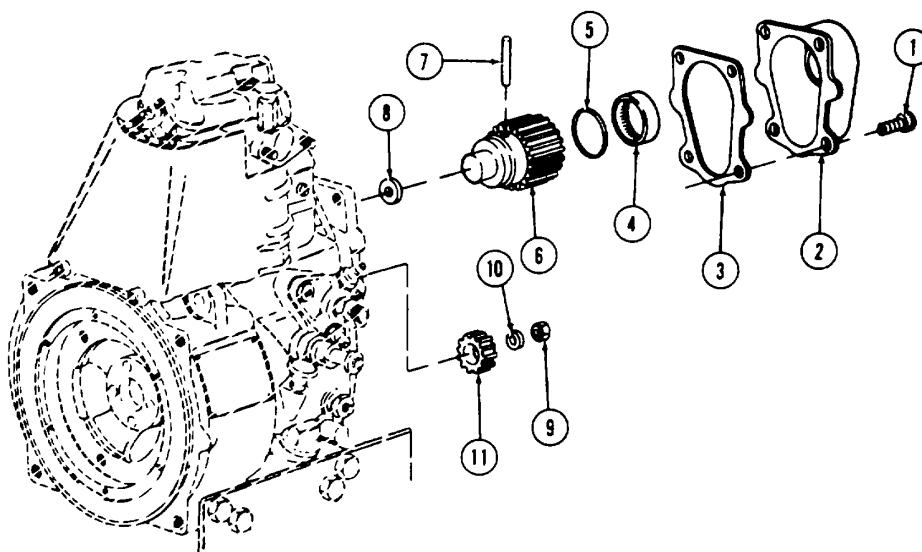
REMOVAL:

- 1 Remove four hexagon socket head cap screws (1) and remove housing (2).
- 2 Remove and discard gasket (3).
- 3 Remove needle shell (4), oil seal (5), gear wheel (6) and stud (7) as an assembly.
- 4 Remove needle shell (4), oil seal (5) and stud (7) from gearwheel (6).
- 5 Remove disc (8).
- 6 Remove hexagon nut (9) and lock washer (10). Discard lock washer.
- 7 Remove pinion (11).

5-9.. REPLACE CRANK ASSEMBLY GEARS (Continued)

CLEANING/INSPECTION:**WARNING**

Dry cleaning solvent P-D-680 (safety or Stoddard's Solvent) is potentially dangerous. Avoid repeated and prolonged breathing of vapors and skin contact with the liquid. Do not use near open flame, arcing equipment, or other ignition sources. Always wear eye protection and protective clothing. The flash point of P-D-680 is 100°F to 138°F (38°C to 59°C).

Death or serious injury could occur if compressed air is directed against the skin. Do not use compressed air for cleaning or drying unless the pressure is/has been reduced to 30 psi (2.06 bar) or less. When working with compressed air always use chip guards, eye protection, and other personal equipment.

- 1 Clean housing (2), gear wheel (6) and pinion (11) with dry cleaning solvent and dry with compressed air.
- 2 Inspect all components for damage or excessive wear. Replace any components severely damaged or worn.

INSTALLATION:**CAUTION**

If either the gear wheel or pinion needs to be replaced, replace both. Timing marks on the small pinion must be aligned with the keyway on the tapered shaft. The timing marks on the gear wheel must be aligned with the mark on the small pinion. Failure to heed this caution can damage equipment.

- 1 Slide pinion (11) onto camshaft. Install new lock washer (10) and hexagon nut (9) and tighten securely.
- 2 Install disc (8) into timing cover housing with graphite side of disc (8) facing outward.
- 3 Lubricate dry bushing in timing cover housing with grease (Item 3, Appendix B).
- 4 Install gear wheel (6) into dry bushing and secure gear wheel (6) with stud (7).
- 5 Install oil seal (5) and needle shell (4) onto gear wheel (6).
- 6 Fill housing (2) with 3-1/2 ounces (110 g) of warm grease (Item 4, Appendix B). Mount new gasket (3) and housing (2) onto timing cover with four hexagon socket head cap screws (1).

5-10. INSPECT/REPLACE CYLINDER HEAD AND VALVE ASSEMBLY

- This task covers:
- a. Removal
 - b. Disassembly
 - c. Cleaning/Inspection
 - d. Assembly/Adjustment
 - e. Installation/Adjustment

INITIAL SETUP

Tools

- Tool Kit, General Mechanics Automotive (Item 1, Appendix B)
- Cylinder Hold Down Clamp (Item 3, Appendix B)
- Dial Gauge (Item 3, Appendix B)
- Measuring Device (Item 3, Appendix B)
- Micrometer, Depth (Item 3, Appendix B)
- Micrometer, Inside (Item 3, Appendix B)
- Retainer Bracket For Cylinder (Item 3, Appendix B)
- Micrometer, Outside (Item 3, Appendix B)
- Torque Wrench (Item 3, Appendix B)

Material/Parts

Dry cleaning solvent (item 10, Appendix E)

Equipment

Para	Condition Description
4-13	Pump housing assembly removed.
4-19	Fuel tank removed.
4-20	Muffler removed.
4-22	Valve cover removed.
5-7	Injector removed from cylinder head.

Materials/Parts

- Gasket
- Preformed packing

General Safety Instructions

Well-ventilated area required.

REMOVAL:

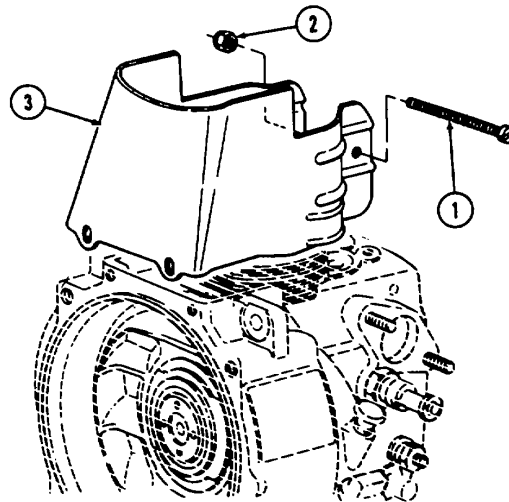

- 1 Remove screw (1) and hexagon nut (2) from cowling (3).
- 2 Remove cowling (3) from engine.

5-10. INSPECT/REPLACE CYLINDER HEAD AND VALVE ASSEMBLY (Continued)

- 3 Remove four hexagon nuts (1) and washers (5) from four studs (2). Remove rocker shaft (3) with rockers, lifting eye and fuel tank bracket. Remove two air shields. Remove deflector (4).

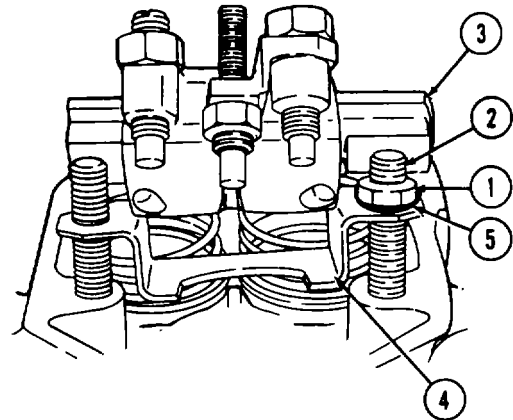

NOTE

Record thickness of gasket (2) to aid in selection of new gasket during installation.

- 4 Remove cylinder head (1) and gasket (2). Discard gasket.

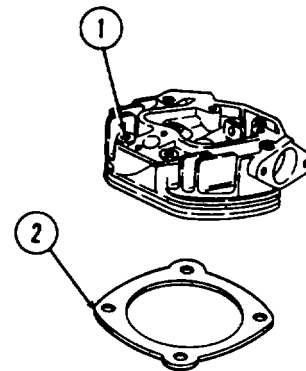

- 5 Remove pushrod (1) and complete pushrod (2) from protection tubes (3).

- 6 Remove protection tubes (3), preformed packing (4), shims (5) and pressure springs (6). Discard preformed packing.

NOTE

Complete pushrod (2) is located on the injection pump side of the engine.

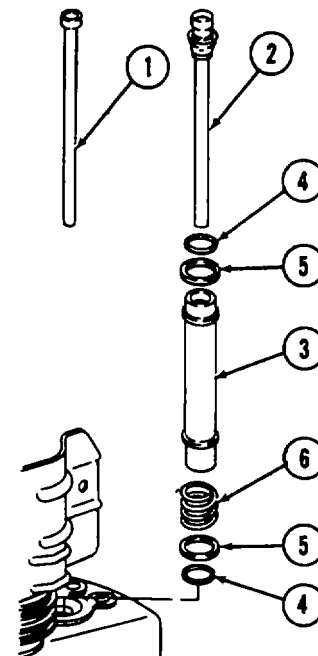

5-10. INSPECT/REPLACE CYLINDER HEAD AND VALVE ASSEMBLY (Continued)

DISASSEMBLY:

CAUTION

Do not scratch the cylinder head sealing face. Scratches could cause poor sealing of cylinder head and cylinder.

- 1 Press down cup (1) and remove collet halves (2) from both valves.
- 2 Remove valve spring (3), washer (4) and cap (5) from both valves.
- 3 Remove valve (6) from cylinder head (7).

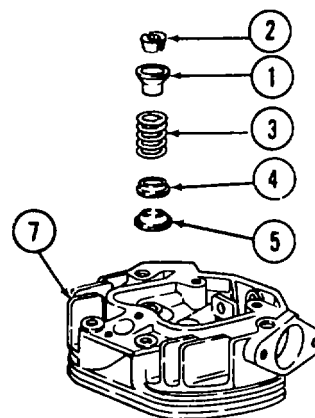

- 4 Remove hexagon nut (1) from threaded stud (2). Remove threaded stud.
- 5 Use needlenose pliers to remove pin (3) with ten spring plates (4) and preformed packing (5) attached.
- 6 Remove and discard preformed packing (5).
- 7 Knock out pin (6) and remove decompression shaft (7) and pinion (8) from cylinder head (9).

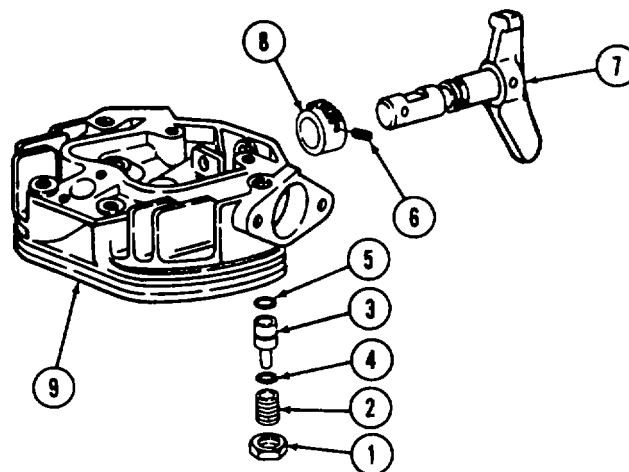
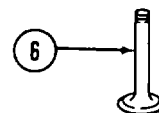

5-10. INSPECT/REPLACE CYLINDER HEAD AND VALVE ASSEMBLY (Continued)

CLEANING/INSPECTION:

WARNING

Dry cleaning solvent P-D-680 (safety or Stoddard's Solvent) is potentially dangerous. Avoid repeated and prolonged breathing of vapors and skin contact with the liquid. Do not use near open flame, arcing equipment, or other ignition sources. Always wear eye protection and protective clothing. The flash point of P-D-680 is 100°F to 138°F (38°C to 59°C).

Death or serious injury could occur if compressed air is directed against the skin. Do not use compressed air for cleaning or drying unless the pressure is/has been reduced to 30 psi (2.06 bar) or less. When working with compressed air always use chip guards, eye protection, and other personal equipment.

- 1 Clean all parts with a clean cloth dampened with dry cleaning solvent. Use wire brush where necessary. Dry with compressed air.
- 2 Inspect all parts for cracks, rust, corrosion, and excessive heat damage.
- 3 Inspect for accumulated carbon around injector seat in cylinder head.
- 4 Replace cylinder head if it is damaged.
- 5 Measure rocker shaft (1) diameter. If rocker shaft diameter is smaller than 0.7074 inch (17.967 mm), R must be replaced.
- 6 Measure rocker bore bushing (2) inside diameter. If rocker bore bushing inside diameter is greater than 0.7076 inch (17.974 mm), replace bushing (2).
- 7 Inspect rocker (3) radius. No flattening or brinelling is permitted on the rocker radius. If there is evidence of flattening, the rocker must be replaced.

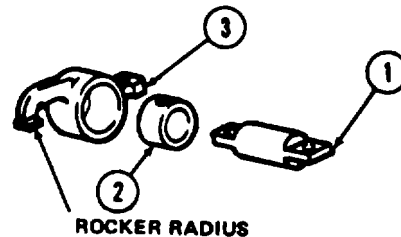
**NOTE**

When replacing rocker (3) you must also replace bushing (2). They are replaced as an assembly. Bushing (2), however, can be replaced separately.

- 8 Inspect valve seats in cylinder head. If there is any evidence of damage, replace the cylinder head.

NOTE

Whenever a valve is replaced, the valve seat must be reconditioned.

- 9 Inspect valves. If there is any evidence of damage or distortion, replace valve and recondition valve seat.

5-10. INSPECT/REPLACE CYLINDER HEAD AND VALVE ASSEMBLY (Continued)

ASSEMBLY/ADJUSTMENT:

- 1 Install pinion (8) in cylinder head (9).
- 2 Insert decompression shaft (7) through cylinder head (9) and into pinion (8).
- 3 Align holes in pinion (8) and decompression shaft (7).
- 4 Install pin (6).
- 5 Install new preformed packing (5) on pin (3).
- 6 Install ten spring plates (4) on pin (3). The spring plates (4) must be installed in live sets with concave sides together to create a spring action.
- 7 Install pin (3) with assembled preformed packing (5) and spring plate (4) into cylinder head (9).
- 8 Rotate decompression shaft (7) to horizontal position.
- 9 Install threaded stud (2) and tighten until snug.
- 10 Secure with hexagon nut (1).

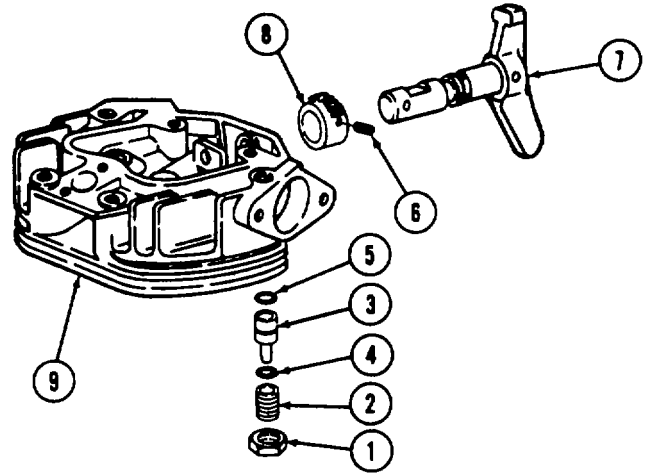

CAUTION

Do not scratch the cylinder head sealing face. Scratches could cause poor sealing of cylinder head and cylinder.

- 11 Insert valve (6) into cylinder head (7).
- 12 Install cap (5), washer (4), valve spring (3) and cup (1).
- 13 Press down on cup (1) and install collets halves (2).

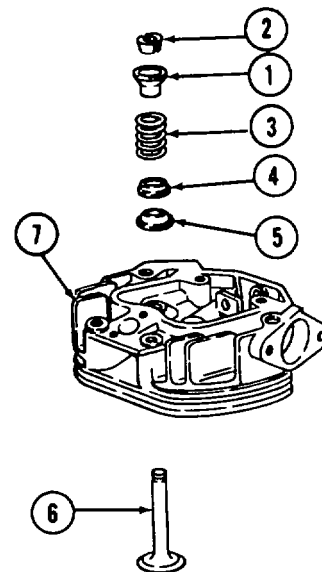

5-10. INSPECT/REPLACE CYLINDER HEAD AND VALVE ASSEMBLY (Continued)

INSTALLATION/ADJUSTMENT:

CAUTION

Too small a clearance will damage piston, cylinder head, and valves. Too large a clearance will result in difficult starting.

- 1 Adjust cylinder head clearance.
 - a. Install spacers on one long cylinder head stud and one short cylinder head stud. Secure with two hexagon nuts and tighten to hold down cylinder.
 - b. Bring the piston to TDC position.
 - c. Measure the distance between the top of the cylinder and the top of the piston with a measuring device. Subtract measurement from required clearance of 0.0217/0.0256 inch (0.55/0.65 mm). The difference is the thickness of the gasket required for proper cylinder head clearance.

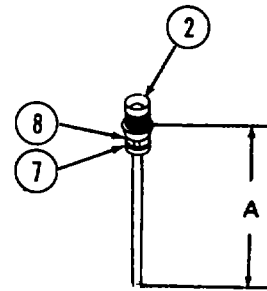
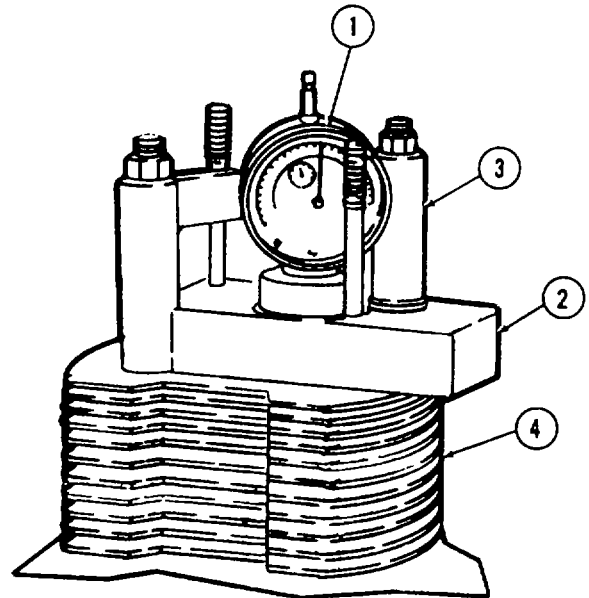

NOTE

Gaskets come in various thicknesses. If you have a choice between two gaskets, it is best to use the thickest one.

- d. Remove the two hexagon nuts and spacers.
- 2 Apply a light coating of grease to both sides of the new cylinder head gasket. Install new cylinder head gasket on cylinder head studs. Align cylinder head gasket to prevent contact with piston.
- 3 Adjust complete pushrod (2) so dimension A equals 5.8189/5.8268 inches (147.8/148.0 mm). Loosen lower locking nut (7), turn upper adjusting nut (8) to achieve adjustment and tighten lower locking nut to maintain proper adjustment. This adjustment is required for proper engagement of complete pushrod with pinion on decompression shaft.
- 4 Install new preformed packings (4), shims (5), pressure springs (6) and protection tubes (3) in engine crankcase.
- 5 Install complete pushrod (2) closest to injection pump side of engine.
- 6 Install pushrod (1) in engine crankcase on fuel lift pump side.

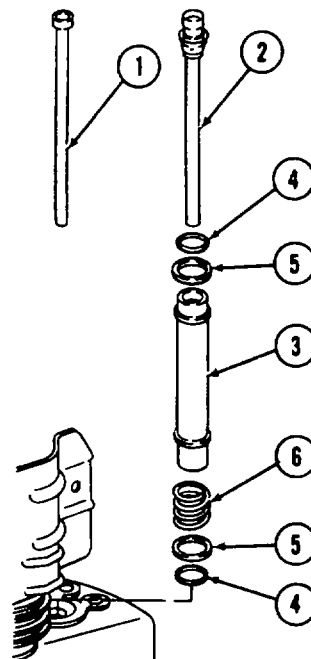

5-10. INSPECT/REPLACE CYLINDER HEAD AND VALVE ASSEMBLY (Continued)

- 7 Install cylinder head (1) on cylinder and new gasket (2).

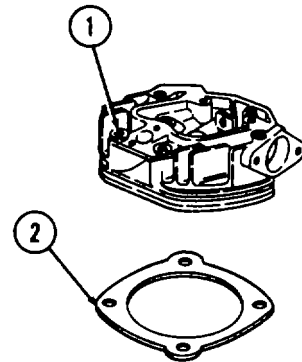

NOTE

Add silicone to all mating surfaces of rocker arm assembly.

- 8 Install rocker shaft (3) with rockers, two air shields, fuel tank bracket and lifting eye. Deepest flat on the rocker shaft must be assembled toward the cylinder or the valves cannot be adjusted. Install deflector (4).
- 9 Install four washers (5) and four nuts (1) on four studs (2) and tighten nuts equally and crosswise to a torque of 47 foot-pounds (6.5 m-kg).
- 10 Install injector (para 5-7).

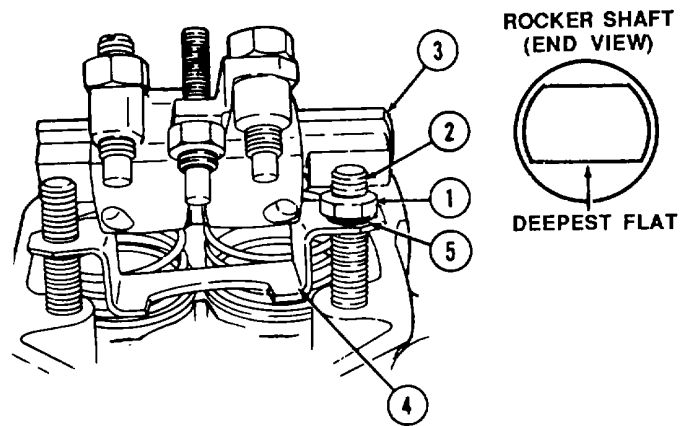

- 11 The adjustment of decompression adjustment screw is required if the engine compresses when the decompression lever is in position 1.
- a. Put decompression lever (1) in position 1.
 - b. Crank engine clockwise when facing throttle control lever until compression resistance can be felt.

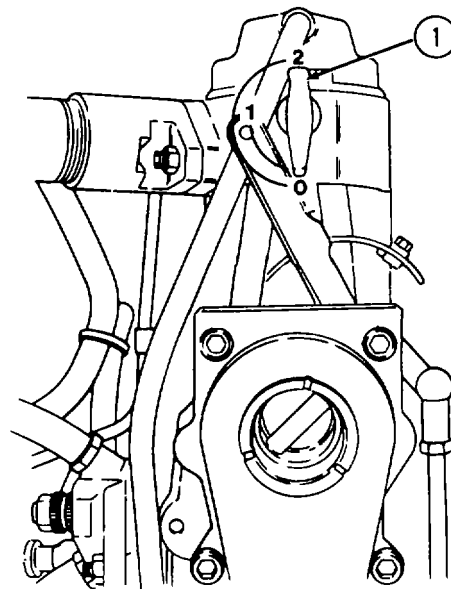

5-10. INSPECT/REPLACE CYLINDER HEAD AND VALVE ASSEMBLY (Continued)

- c. Loosen nut (2) and turn adjustment screw (1) clockwise until rocker touches valve stem.
- d. Turn adjustment screw (1) another half turn and secure by tightening nut (2).

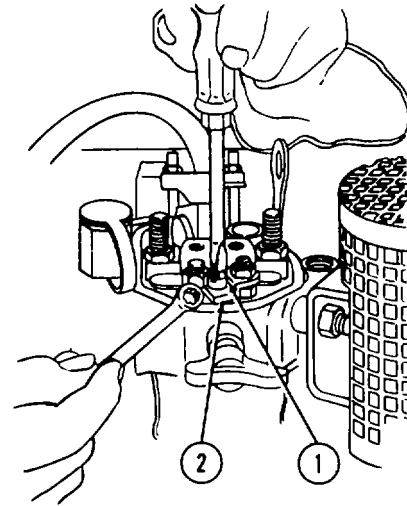

- 12 Adjust tappet clearance (para 4-22).
- 13 If decompression lever does not ratchet, check clearance of complete pushrod (1) and pinion (2).
 - a. Use feeler gauge to check that clearance (3) between socket of complete pushrod (1) and pinion (2) is 0.039 inch (1.0 mm).
 - b. Check that clearance (4) is 0.039 inch (1.0 mm).
 - c. Clearances can be adjusted by adjusting complete pushrod (1) for clearance (3), and adjusting rocker shaft for clearance (4). To adjust complete pushrod, loosen lower locking nut on pushrod, turn upper adjusting nut on pushrod to achieve adjustment and tighten lower locking nut to maintain proper adjustment.

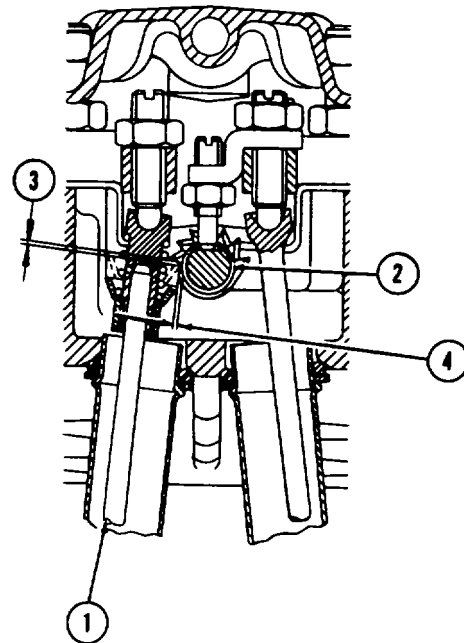

Note

During engine operation, decompression shaft must not move. Assured clearance will prevent movement.

5-10. INSPECT/REPLACE CYLINDER HEAD AND VALVE ASSEMBLY (Continued)

- 14 Install cowling (3) on engine.
- 15 Install screw (1) and hexagon nut (2).

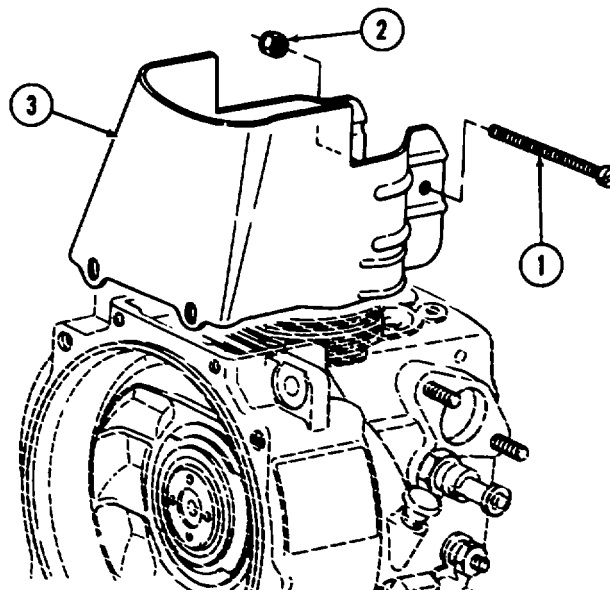

- 16 Install gasket (6) on cylinder head.
- 17 Install cylinder head cover (5) on gasket (6).
- 18 Install two wave washers (4) and hexagon nuts (3). Tighten securely
- 19 Install pipe clip (2), washers (7) and hexagon head screw (1).

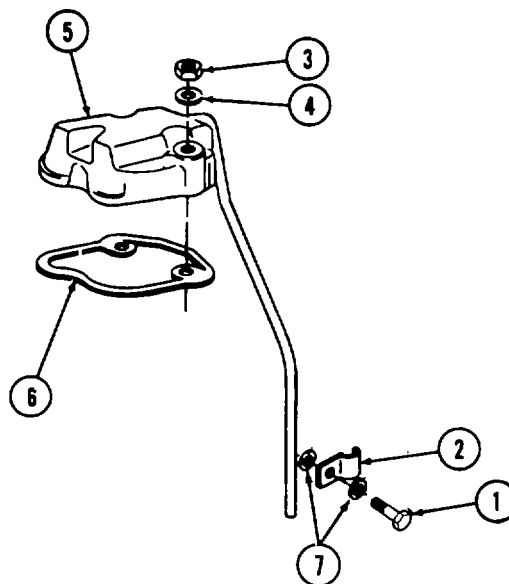

5-11. INSPECT/REPLACE CYLINDER

This task covers: a. Removal c. Installation
 b. Cleaning/Inspection

INITIAL SETUP

Tools

Tool Kit, General Mechanics Automotive
 (Item 1, Appendix B)

Piston Ring Clamp
 (Item 3, Appendix B)

Piston Ring Pliers
 (Item 3, Appendix B)

**Equipment
 Condition
 Para**

5-10

Condition Description

Cylinder head removed.

General Safety Instructions

Well-ventilated area required.

Materials/Parts

Dry cleaning solvent (Item 2, Appendix E)
 Lubricating oil (Item 6, Appendix E)
 Marking color (Item 1, Appendix E)

REMOVAL:



When removing cylinder, make sure piston or connecting rod does not knock against crankcase. This could result in serious damage to piston or connecting rod.

- 1 Matchmark cylinder (1) and crankcase (2) with marking color to make sure of proper installation during assembly.
- 2 Pull cylinder (1) from crankcase (2).

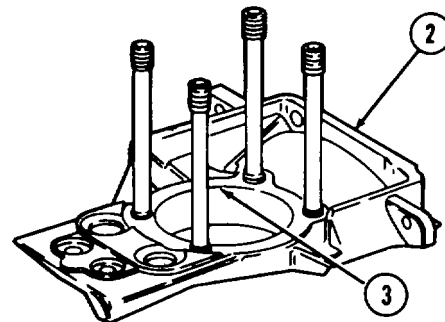
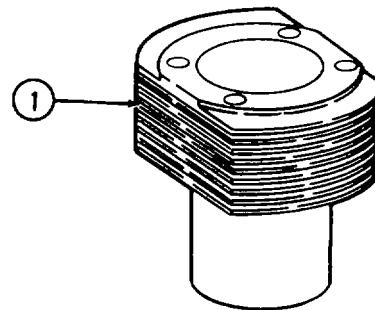

5-11. INSPECT/REPLACE CYLINDER (Continued)

CLEANING/INSPECTION:

WARNING

Dry cleaning solvent P-D-680 (safety or Stoddard's Solvent) is potentially dangerous. Avoid repeated and prolonged breathing of vapors and skin contact with the liquid. Do not use near open flame, arcing equipment, or other ignition sources. Always wear eye protection and protective clothing. The flash point of P-D-680 is 100°F to 138°F (38°C to 59°C).

Death or serious injury could occur if compressed air is directed against the skin. Do not use compressed air for cleaning or drying unless the pressure is/has been reduced to 30 psi (2.06 bar) or less. When working with compressed air always use chip guards, eye protection, and other personal equipment.

- 1 Clean cylinder seats (3) in crankcase (2) with dry cleaning solvent and dry with compressed air. Check that cylinder seats are smooth and flat.
- 2 Clean cylinder thoroughly with dry cleaning solvent. Dry with compressed air. Inspect for damage, warpage, rust, or corrosion. If severely damaged or warped, replace with new cylinder and piston.

NOTE

For piston replacement instructions refer to paragraph 5-12.

- 3 Inspect cylinder for cracks. Inspect for scoring, glazing, or a ridge on the upper portion of inner surface. Inspect for metal particles (fretting) on outer surface. Replace damaged cylinder with new cylinder and piston.

5-11. INSPECT/REPLACE CYLINDER (Continued)

- 4 Measure cylinder bore at 4 depths. A normal or new bore diameter should be 2.8740 to 2.8774 inches (73.00 to 73.01 mm). If wear limits for a normal bore cylinder have been reached or exceeded, replace cylinder and piston. If measurements on axis A and B are different, cylinder is out-of-round or has high spots. Replace cylinder and piston.
- 5 Check that the top and bottom piston faces are smooth and flat. If damaged, replace cylinder and piston.

INSTALLATION:

- 1 Install piston (1) in accordance with paragraph 5-12. Apply lubricating oil to piston rings.
- 2 Check that piston rings are offset by 120 degrees.
- 3 Compress piston rings with piston ring clamp (2).

CAUTION

When installing cylinder, make sure piston or connecting rod does not knock against crankcase. This could result in serious damage to piston or connecting rod.

Use care when installing cylinder to prevent damage to piston rings.

- 4 Apply lubricating oil to inside of cylinder (3) and slowly mount cylinder on studs (4).
- 5 Remove piston ring clamp (2).

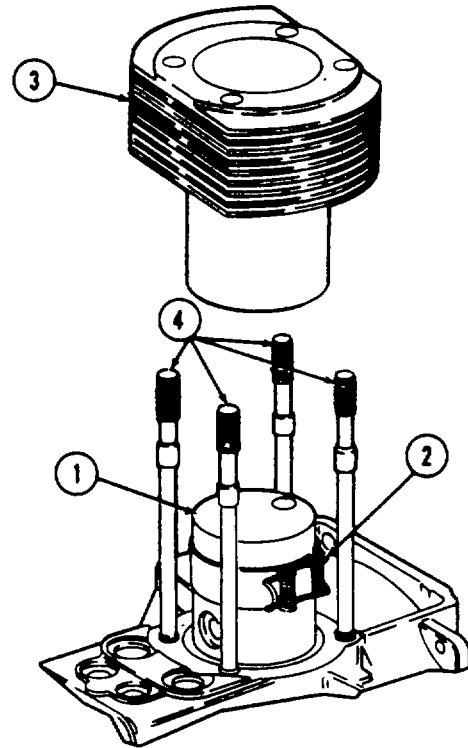
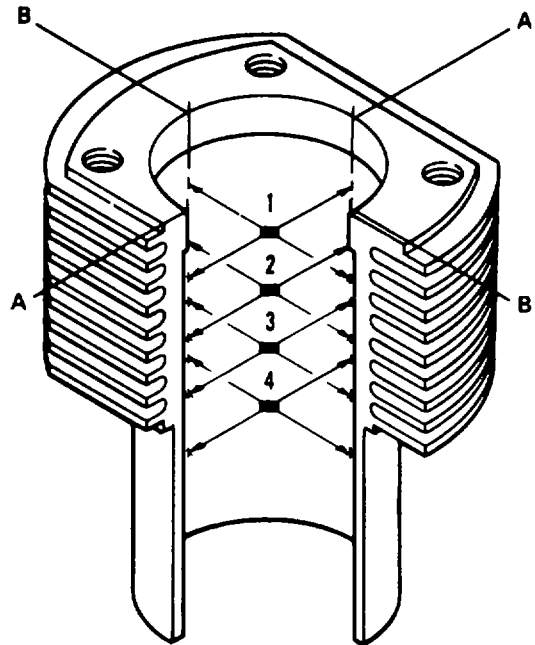

5-12. INSPECT/REPAIR/REPLACE PISTON

This task covers: a. Removal c. Cleaning e. Repair
 b. Disassembly d. Inspection f. Assembly

INITIAL SETUP

Tools

Tool Kit, General Mechanics Automotive
 (Item 1, Appendix B)

Gudgeon Pin Extractor (Item 3, Appendix B)

Micrometer, Outside (Item 3, Appendix B)

Piston ring Pliers (Item 3, Appendix B)

Caliper (Item 3, Appendix B)

**Equipment
 Condition
 Para**

5-11

Condition Description

Cylinder removed from engine.

Materials/Parts

Dry cleaning solvent (Item 10, Appendix E)
 Lubricating oil (Item 6, Appendix E)
 Retaining ring

General Safety Instructions

Well-ventilated area required.

REMOVAL:



When removing cylinder, make sure piston or connecting rod does not knock against crankcase. This could result in serious damage to piston or connecting rod.

- 1 Remove and discard retaining ring (1).
- 2 Press out gudgeon pin (2) far enough to remove gudgeon pin and piston (3) from connecting rod (4).
- 3 Remove piston (3) and gudgeon pin (2).
- 4 Remove and discard retaining ring (5).

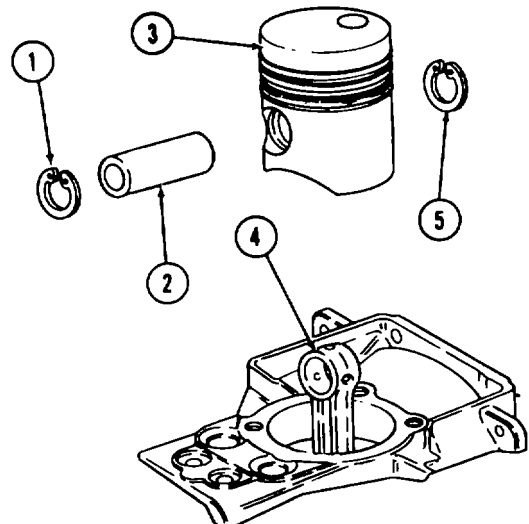

5-12. INSPECT/REPAIR/REPLACE PISTON (Continued)

DISASSEMBLY:

- 1 Remove gudgeon pin (1) from piston (2) using gudgeon pin extractor if necessary.

CAUTION

Piston ring breakage may occur if rings are opened more than necessary when removing or installing them. Do not strain rings.

- 2 Remove piston ring set (3) from piston (2) with piston ring pliers.

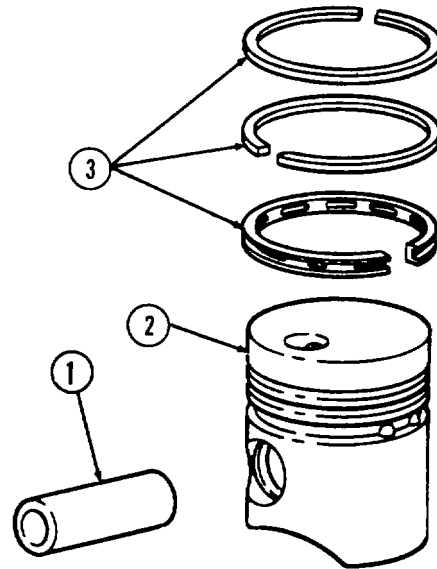

CLEANING:

WARNING

Dry cleaning solvent P-D-680 (safety or Stoddard's Solvent) is potentially dangerous. Avoid repeated and prolonged breathing of vapors and skin contact with the liquid. Do not use near open flame, arcing equipment, or other ignition sources. Always wear eye protection and protective clothing. The flash point of P-D-680 is 100°F to 138°F (38°C to 59°C).

Death or serious injury could occur if compressed air is directed against the skin. Do not use compressed air for cleaning or drying unless the pressure is/has been reduced to 30 psi (2.06 bar) or less. When working with compressed air always use chip guards, eye protection, and other personal equipment.

- 1 Clean piston (2) and gudgeon pin (1) with dry cleaning solvent and dry with compressed air.
- 2 Remove carbon from piston ring lands and grooves.
- 3 Clean inside surface of piston and piston skirt.
- 4 Clean gudgeon pin bore.

5-12. INSPECT/REPAIR/REPLACE PISTON (Continued)

INSPECTION:

- 1 Inspect piston, piston skirt, and piston grooves for excessive wear and damage. Replace damaged piston.

NOTE

Excessively worn piston, rings or cylinder may be an indication of abnormal maintenance procedures or operating conditions. Check for and correct any abnormalities.

- 2 Examine piston (1) for scoring, fretting, pitting, cracks (especially on the interior surfaces), damaged ring grooves (2) or lands (3), or for indications of overheating. Repair slight scoring according to repair procedure. Replace damaged piston.
- 3 K piston is badly worn or damaged, check cylinder for excessive out-of-round, high spots, or other damage in accordance with paragraph 5-11.

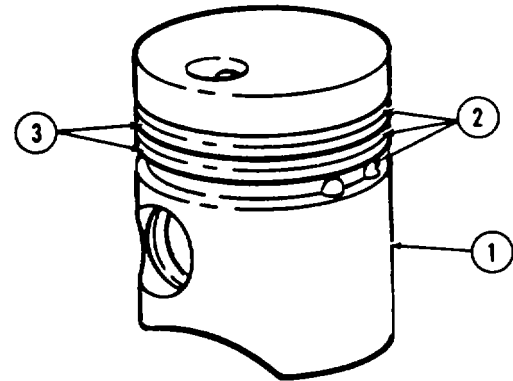

- 4 Measure piston diameter (1) along axis A and B. A normal or new piston diameter should be 2.8724 inches (72.96 mm). If piston is out-of-round, replace piston.

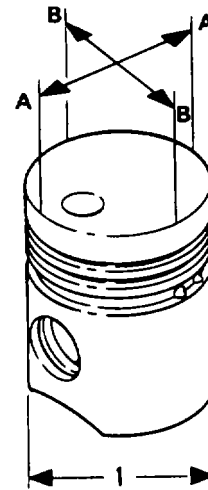

5-12. INSPECT/REPAIR/REPLACE PISTON (Continued)

- 5 Measure piston compression ring groove (1) width. Measurement should be 0.0826 to 0.0843 inch (2.100 to 2.143 mm). If measurement is greater than 0.0843 inch (2.143 mm), replace piston.
- 6 Measure piston ring groove (2) width. Measurement should be 0.0811 to 0.0908 inch (2.060 to 2.310 mm). If measurement is greater than 0.0908 inch (2.310 mm), replace piston.
- 7 Measure piston oil control ring groove (3) width. Measurement should be 0.1582 to 0.1599 inch (4.020 to 4.060 mm). If measurement is greater than 0.1599 inch (4.060 mm), replace piston.

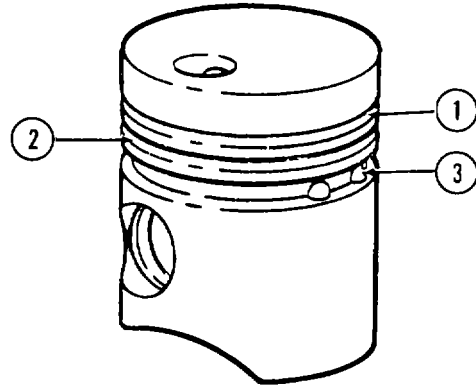
**WARNING**

Dry cleaning solvent P-D-680 (safety or Stoddard's Solvent) is potentially dangerous. Avoid repeated and prolonged breathing of vapors and skin contact with the liquid. Do not use near open flame, arcing equipment, or other ignition sources. Always wear eye protection and protective clothing. The flash point of P-D-680 is 100°F to 138°F (38°C to 59°C).

Death or serious injury could occur if compressed air is directed against the skin. Do not use compressed air for cleaning or drying unless the pressure is/has been reduced to 30 psi (2.06 bar) or less. When working with compressed air always use chip guards, eye protection, and other personal equipment.

- 8 If any ring groove width measurements are smaller than the minimum values given above, piston ring grooves may be clogged with carbon deposits. Clean piston with dry cleaning solvent. Dry with compressed air. Take measurements again.
- 9 Inspect gudgeon pin for scoring, fretting, pitting, or indications of overheating. If severely damaged, replace gudgeon pin.

REPAIR:

Remove slight scoring or fretting on piston. Clean and repeat procedure if necessary.

5-12. INSPECT/REPAIR/REPLACE PISTON (Continued)

ASSEMBLY:

- 1 If cylinder has been replaced, piston must also be replaced.



Piston rings are marked TOP and should be installed as marked. Piston ring breakage may occur if rings are opened more than necessary when removing or installing them. Do not strain rings.

- 2 If piston replacement is necessary, piston rings must also be replaced.
- 3 Install piston rings with piston ring pliers. Install oil control ring (1), cast iron compression ring (2) and chrome compression ring (3) in order. Be careful not to strain rings by opening them too wide during installation. Make sure that the piston ring gaps are equally spaced around the piston 120 degrees from each other.

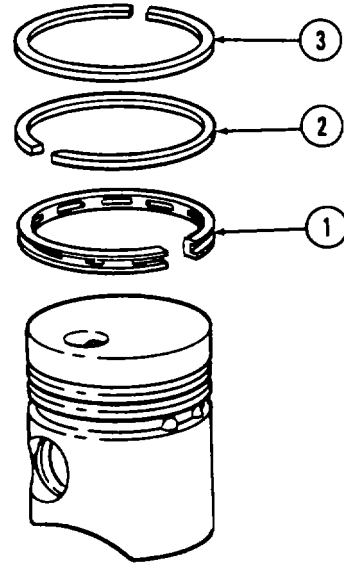

- 4 Install new retaining ring (1) in lip groove of piston (3) gudgeon bore.



When installing cylinder, make sure piston or connecting rod does not knock against crankcase. This could result in serious damage to piston or connecting rod.

- 5 Insert connecting rod (4) into bottom of piston (3). Make sure that combustion chamber opening (5) is on the flywheel side.
- 6 Insert gudgeon pin (2) into piston (3) gudgeon bore and through rod bushing of connecting rod (4). Push in gudgeon pin until it contacts installed retaining ring (1) and stops.
- 7 Install second new retaining ring (1).

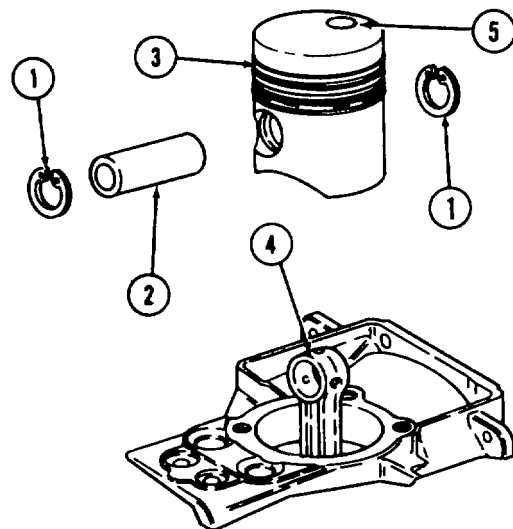

5-13. REPLACE/REPAIR FLYWHEEL

This task covers: a. Removal c. Installation
b. Repair

INITIAL SETUP**Tools**

Tool Kit, General Mechanics Automotive
(Item 1, Appendix B)

Torque Wrench (Item 3, Appendix B)

Socket (item 4, Appendix B)

**Equipment
Condition
Para**

4-13

Condition Description

Engine shut down and cool.

Pump housing assembly removed.

Materials/Parts

Dry cleaning solvent (Item 10, Appendix E)
Lock washers

General Safety Instructions

Well-ventilated area required.

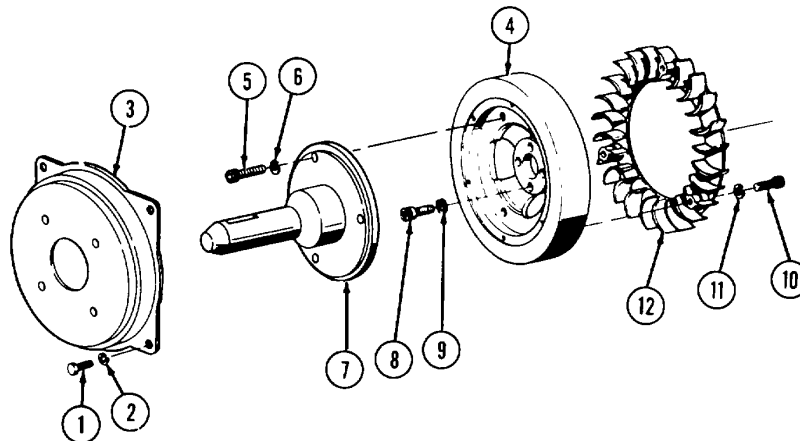
REMOVAL:

- 1 Remove four hexagon head screws (1) and lock washers (2). Remove engine adapter housing (3) to expose engine flywheel. Discard the lock washers.
- 2 Restrain flywheel (4).
- 3 Remove three hexagon socket head screws (5) and three lock washers (6). Discard the lock washers.
- 4 Remove stub shaft (7).
- 5 Remove four hexagon socket head screws (8) and four lock washers (9). Discard the lock washers.
- 6 Remove flywheel (4).
- 7 Use socket (Item 4, Appendix B) to remove three special socket head screws (10).
- 8 Remove and discard three lock washers (11).
- 9 Separate blower ring (12) from flywheel (4).

5-13. REPLACE/REPAIR FLYWHEEL

REPAIR:

WARNING

Dry cleaning solvent P-D-680 (safety or Stoddard's Solvent) is potentially dangerous. Avoid repeated and prolonged breathing of vapors and skin contact with the liquid. Do not use near open flame, arcing equipment, or other ignition sources. Always wear eye protection and protective clothing. The flash point of P-D-680 is 100°F to 138°F (38°C to 59°C).

Death or serious injury could occur if compressed air is directed against the skin. Do not use compressed air for cleaning or drying unless the pressure is/has been reduced to 30 psi (2.06 bar) or less. When working with compressed air always use chip guards, eye protection, and other personal equipment.

- 1 Clean flywheel thoroughly with dry cleaning solvent. Use wire brush if necessary.
- 2 Dry flywheel with compressed air.
- 3 Inspect flywheel for cracks, rust, corrosion or other damage.
- 4 Replace damaged or cracked flywheel.
- 5 Clean blower ring thoroughly with dry cleaning solvent. Use a soft-bristle brush to clean blower ring blades.
- 6 Dry blower ring with compressed air.
- 7 Inspect blower ring for cracks and other damage.
- 8 If blower ring blades are damaged, cracked, or chipped, replace blower ring.
- 9 Smooth out nicks or burrs on flywheel and blower ring. Remove rust or corrosion, then clean with dry cleaning solvent.
- 10 Dry with compressed air.

5-13. REPLACE/REPAIR FLYWHEEL (Continued)

INSTALLATION:

- 1 Align blower ring (12) holes with mounting holes on flywheel (4).
 - 2 Install three new lock washers (11) and special socket head screws (10).
 - 3 Using socket (Item 4, Appendix B), tighten special socket head screws to 22.13 foot-pounds (30 N-m).
 - 4 Install four hexagon socket head screws (8) and new lock washers (9) through flywheel (4) and into engine crankshaft.
 - 5 Restrain flywheel (4).
 - 6 Tighten hexagon socket head screws (8) to 51.6 foot-pounds (70 N-m).
 - 7 Take restraint off flywheel. Make sure flywheel turns freely.
 - 8 Install stub shaft (7), and secure to flywheel (4) with three new lock washers (6) and three hexagon socket head screws (5).
 - 9 Install engine adapter housing (3) and secure with four hexagon head screws (1) and four new lock washers (2).
-

5-14. INSPECT/REPLACE/REPAIR FRAME ASSEMBLY (FRAME, RAILS, AND SHOCK MOUNTS)

This task covers: a. Removal c. Repair
 b. Cleaning/Inspection d. Installation

INITIAL SETUP

Tools

Tool Kit, General Mechanics Automotive
 (Item 1, Appendix B)

Materials/Parts

Dry cleaning solvent (Item 10, Appendix E)
 Zinc chromate primer coating (Item 9, Appendix E)
 Lock washers

**Equipment
 Condition
 Para**

4-14 Pump removed from engine.
 5-5 Engine removed from frame.

Condition Description

General Safety Instructions

Well-ventilated area required.

REMOVAL:

- 1 Remove two hexagon head cap screws (1), hexagon nuts (2) lock washers (3), and flat washers (4). Discard the lock washers.
- 2 Remove left mounting bracket (5) from frame (6). Remove two shock mounts (7).
- 3 Remove two hexagon head cap screws (1), hexagon nuts (2) lock washers (3), and flat washers (4). Discard the lock washers.
- 4 Remove right mounting bracket (8) from frame (6). Remove two shock mounts (7).

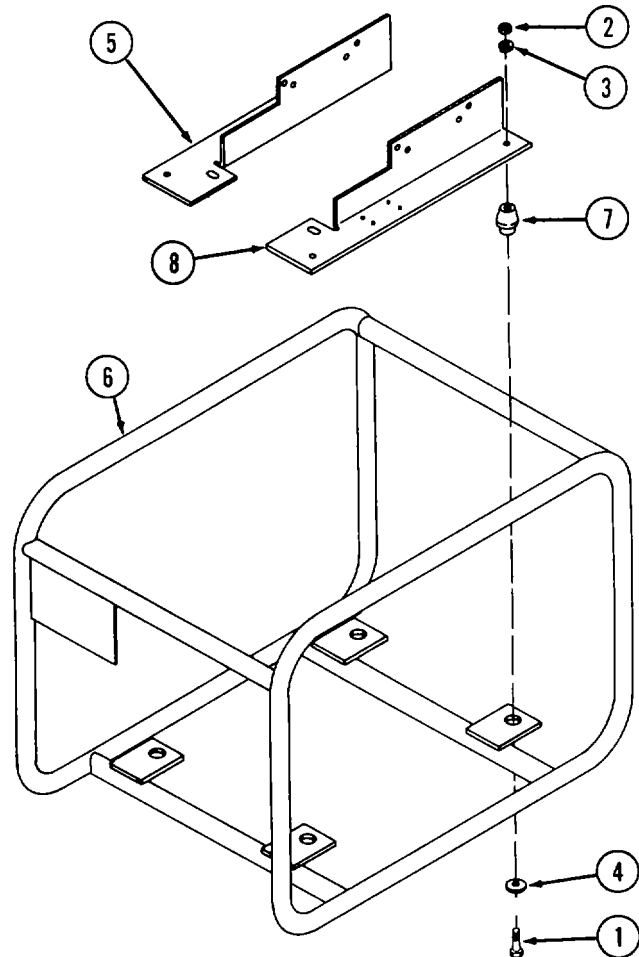

5-14. INSPECT/REPLACE/REPAIR FRAME ASSEMBLY (FRAME, RAILS AND SHOCK MOUNTS)
(Continued)

CLEANING/INSPECTION:**WARNING**

Dry cleaning solvent P-D-680 (safety or Stoddard's Solvent) is potentially dangerous. Avoid repeated and prolonged breathing of vapors and skin contact with the liquid. Do not use near open flame, arcing equipment, or other ignition sources. Always wear eye protection and protective clothing. The flash point of P-D-680 is 100°F to 138°F (38°C to 59°C).

Death or serious injury could occur if compressed air is directed against the skin. Do not use compressed air for cleaning or drying unless the pressure is/has been reduced to 30 psi (2.06 bar) or less. When working with compressed air always use chip guards, eye protection, and other personal equipment.

- 1 Using dry cleaning solvent and stiff-bristled brush, clean all parts thoroughly. Dry with compressed air.
- 2 Inspect left mounting bracket (5), right mounting bracket (8) and frame (6) for dents, rust, corrosion, structural damage, or warpage. If damaged or warped, repair.
- 3 Inspect shock mounts (7) for brittleness and deterioration.

REPAIR:

If frame has broken welds, chip away loose material before reworking welds.

INSTALLATION:

- 1 Install shock mounts (7) in frame (6) brackets.
 - 2 Install two hexagon head cap screws (1), flat washers (4), new lock washers (3) and hexagon nuts (2) and secure right mounting bracket (8) to frame (6). Tighten hexagon nuts (2) securely.
 - 3 Install two hexagon head cap screws (1), flat washers (4), new lock washers (3) and hexagon nuts (2) and secure left mounting bracket (5) to frame (6). Tighten hexagon nuts (2) securely.
-

CHAPTER 6
GENERAL SUPPORT MAINTENANCE INSTRUCTIONS

Section I. TROUBLESHOOTING

No troubleshooting procedures are required.

Section II. MAINTENANCE PROCEDURES

INDEX

	Para		Para
Camshaft	6-4	Governor	6-5
Connecting rod	6-3	Injection Pump	6-9
Crankcase	6-8	Oil seal	6-6
Crankshaft	6-7	Timing cover	6-4
Cylinder head and valve assembly	6-2	Valves	6-2

6-1. GENERAL INSTRUCTIONS

Maintenance instructions in this section will list resources required, personnel required and equipment condition for the start of the procedure. Note the following:

- Resources required are not listed unless they apply to the procedure.
- Personnel required are listed only if the task requires more than one. If PERSONNEL is not listed, it means one person can do the task.
- The normal standard equipment condition to start a maintenance task is engine stopped. EQUIPMENT CONDITION is not listed unless some other condition is required.

6-2. REPAIR CYLINDER HEAD AND VALVE ASSEMBLY

This task covers: a. Cleaning/Inspection c. Test
 b. Repair

INITIAL SETUP

Tools

- Tool Kit, General Mechanics Automotive (Item 1, Appendix B)
- Clamping Holder To Grind Valve-Valve Seat (Item 3, Appendix B)
- Valve Reseating Tool, 42.5 MM Dia (Item 3, Appendix B)
- Guiding Pin, 7 MM Dia (valve reseating tool) (Item 3, Appendix B)
- Hand Reamer, 7 MM Dia (Item 3, Appendix B)
- Press-In Mandrel, 7 MM Dia (Valve Guide) (Item 3, Appendix B)
- Handle For Valve Reseating Tool (Item 3, Appendix B)

Materials/Parts

- Dry cleaning solvent (item 10, Appendix E)
- Lapping and grinding compound 600 grit (Item 5, Appendix E)

Equipment Condition Para

Condition Description

- 5-5 Injector removed from cylinder head.
- 5-7 Cylinder head removed from engine. Rocker and valves removed from cylinder head.

General Safety Instructions

Well-ventilated area required.

CLEANING/INSPECTION:



Dry cleaning solvent P-D-680 (safety or Stoddard's Solvent) is potentially dangerous. Avoid repeated and prolonged breathing of vapors and skin contact with the liquid. Do not use near open flame, arcing equipment, or other ignition sources. Always wear eye protection and protective clothing. The flash point of P-D-680 is 100°F to 138°F (38°C to 59°C).

Death or serious injury could occur if compressed air is directed against the skin. Do not use compressed air for cleaning or drying unless the pressure is/has been reduced to 30 psi (2.06 bar) or less. When working with compressed air always use chip guards, eye protection, and other personal equipment.

- 1 Clean cylinder head with a clean cloth dampened with dry cleaning solvent. Use wire brush where necessary. Dry with compressed air.
- 2 Inspect cylinder head for cracks, rust, corrosion, and excessive heat damage. Inspect for accumulated carbon.

6-2. REPAIR CYLINDER HEAD AND VALVE ASSEMBLY

- 3 Replace cylinder head if any of the following conditions exist: If the cylinder contact surface (2) is roughened, not level and cannot be repaired; if the valve seats are so worn that recutting is no longer possible; if cylinder head cover surface (1) for cylinder head cover is rough or damaged; or if there are cracks between the valve seats.
- 4 Check that the inside diameter of each valve guide does not exceed 0.2780 inch (7.059 mm).
- 5 Check that valve seat angle does not exceed 45 degrees.
- 6 Clean valves with dry cleaning solvent and dry with compressed air.
- 7 Inspect valves for warpage, burning, or other damage.
- 8 Inspect valve stems (3) for scratches, scuff marks, or other damage.
- 9 Inspect valve tulips(4) , valve joint faces (5) and valve heads (6) for pitting, ridges, or cracks.
- 10 Check that each valve stem (3) diameter is not less than 0.2716 inch (6.95 mm).
- 11 Check that each valve head (6) diameter is not less than 1.200 inches (30.5 mm).

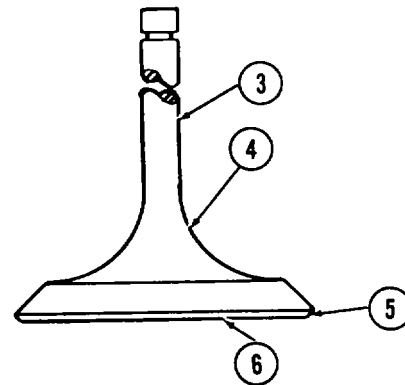
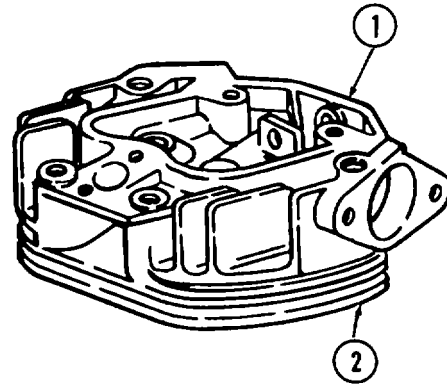

REPAIR:

- 1 If the inside diameter of the valve guide (1) exceeds 0.2780 inch (7.059 mm), replace valve guide. Press out valve guide using mandrel.
- 2 From cylinder head bottom (3) , push valve guide (1) out of cylinder head (2). Insert new valve guide (1) into cylinder head (2). Install new valve guide by pressing in with mandrel. Minimum inserting pressure is 220 inch-pounds (245 cm-kg).
- 3 Ream the inside diameter of the valve guide to 0.2756/0.2759 inch (7.000/7.009 mm) using hand reamer.
- 4 Repair defective cylinder head valve seats by recutting with a 45 degree valve seat cutter. Recut valve seats with valve reseating tool, guiding pin and handle for valve reseating tool. Cut until valve seat is absolutely clean.

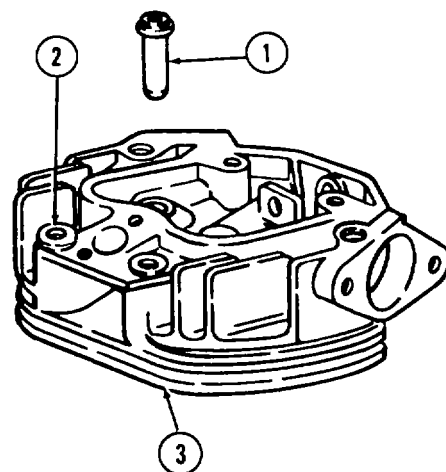

6-2. REPAIR CYLINDER HEAD AND VALVE ASSEMBLY (Continued)

- 5 The cylinder contact surface of the cylinder head can be repaired by machining. Remove up to a maximum of 0.0196 inch (0.5 mm) of metal provided the minimum valve recession is maintained.
- 6 Replace any valves that show head warping, burning, or other damage.
- 7 Replace valves that have seriously scratched or scuffed stems, or pitted, ridged, or cracked tulips, faces, or heads.
- 8 Replace valves that have a valve head diameter of less than 1.200 inch (30.5 mm).
- 9 Remove slight scratches or scuff marks.
- 10 If the cylinder head valve seats were recut, lap the valves by using valve reseating tool and 600 grit lapping and grinding compound.



The valve recession must not be less than 0.018 inch (0.45 mm), otherwise valve head may touch piston.

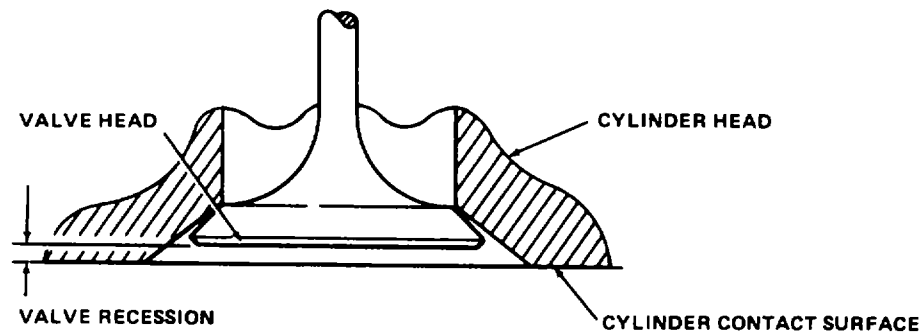

- 11 After lapping valves, check valve recession. The valve recession shall be a maximum of 0.036 inch (0.90 mm) and a minimum of 0.018 inch (0.45 mm).

TEST:

- 1 Insert valve (1) into cylinder head (2).
- 2 Install cap (3) over valve (1) stem.
- 3 Install washer (4) on cap (3).
- 4 Install spring (5) on washer (4).
- 5 Insert cup (6) into spring (5).
- 6 Install two collet halves (7) into cup (6) and over valve (1) stem.
- 7 Press down on collet halves (7) and cup (6) until spring (5) compress and collet halves (7) are locked in slot in valve (1) stem.

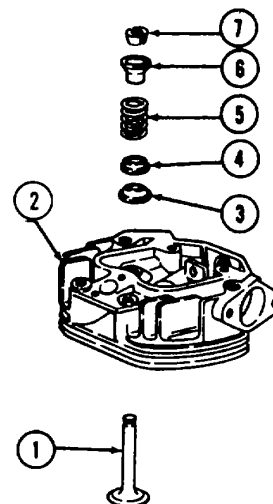

6-2. REPAIR CYLINDER HEAD AND VALVE ASSEMBLY (Continued)

WARNING

Death or serious injury could occur if fuel is not handled carefully. Use in a well-ventilated area away from open flame, arcing equipment, ignition sources, heaters, or excessive heat. Engine must be turned off and cool before refueling. Always store fuel in properly marked containers. **DO NOT SMOKE.**

- 8 Check proper fit of valves by pouring fuel into intake and exhaust ports. Observe for leakage at valve seats. A valve fits properly if no fuel trickles through.
-

6-3. REPAIR/REPLACE CONNECTING ROD

This task covers: a. Removal c. Repair
 b. Inspection d. Installation

INITIAL SETUP

Tools

Tool Kit, General Mechanics Automotive
 (Item 1, Appendix B)

**Equipment
 Condition
 Para**

5-10

Condition Description

Piston removed from engine.

Materials/Parts

Dry cleaning solvent (Item 10, Appendix E)
 Lubricating oil (Item 6, Appendix E)
 Preformed packing
 Hexagon head cap screws

General Safety Instructions

Well-ventilated area required.

REMOVAL:

- 1 Remove cover (1) with four caps (2) and hexagon socket head cap screws (3).
- 2 Remove and discard preformed packing (4).

CAUTION

When removing cylinder, make sure piston or connecting rod does not knock against crankcase. This could result in serious damage to connecting rod.

- 3 Remove two hexagon socket head cap screws (5) and remove bottom half of connecting rod (6).
- 4 Remove top half of connecting rod (7) from top of crankcase.
- 5 Remove two bearing halves (8) from both halves of connecting rod (6 and 7).

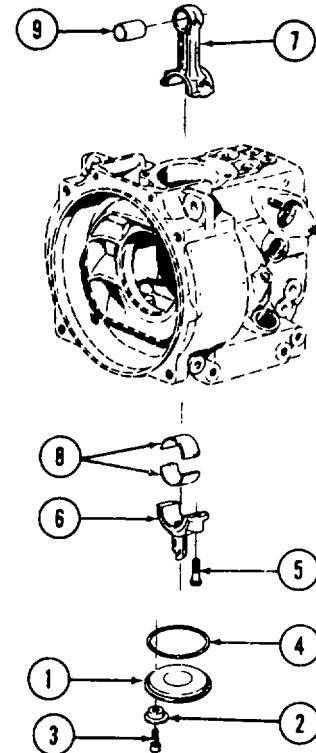

6-3. REPAIR/REPLACE CONNECTING ROD (Continued)

INSPECTION:

WARNING

Dry cleaning solvent P-D-680 (safety or Stoddard's Solvent) is potentially dangerous. Avoid repeated and prolonged breathing of vapors and skin contact with the liquid. Do not use near open flame, arcing equipment, or other ignition sources. Always wear eye protection and protective clothing. The flash point of P-D-680 is 100°F to 138°F (38°C to 59°C).

Death or serious injury could occur if compressed air is directed against the skin. Do not use compressed air for cleaning or drying unless the pressure is/has been reduced to 30 psi (2.06 bar) or less. When working with compressed air always use chip guards, eye protection, and other personal equipment.

- 1 Clean connecting rod components with dry cleaning solvent. Remove any carbon deposits with a wire brush. Clean inside surface of rod bushing (9), both connecting rod halves (6 and 7), and bearing (8). Blow compressed air through the drilled oil passage in connecting rod to clean connecting rod and rod bushing.
- 2 Visually inspect connecting rod for bending, warping, cracking, rust, or other damage. Replace if twisted or bent. Grind or replace if cracked.
- 3 Measure and record rod bushing (9) inside diameter. Measure at points 1 and 2 along axis A and B. Measurements should be 0.9951 to 0.9858 inch (25.225 to 25.040 mm). If any measurement is outside these limits, replace rod bushing.
- 4 Inspect upper and lower bearing halves (8) for excessive wear, scoring, pitting, flaking, etching, and signs of overheating. Inspect bearing backs for bright spots (bearing moving in supports). Replace if excessively worn, scored, pitted, etched, or signs of overheating are noted.
- 5 Temporarily assemble connecting rod with two new hexagon socket head cap screws and without bearing halves. Using a torque wrench, tighten screws to 29.50 foot pounds (40 N-m). Apply some oil to threads and contact surfaces.
- 6 Measure inside diameter of connecting rod bearing bore. Measurement should be 1.8114 to 1.8107 inches (46.010 to 45.994 mm). If measurement is outside specified limits, replace connecting rod.

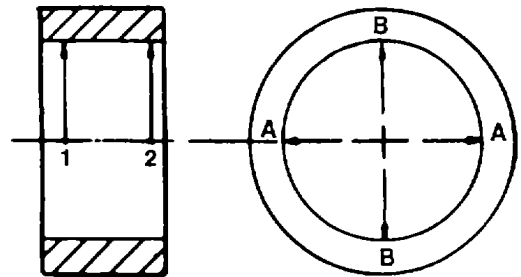

6-3. REPAIR/REPLACE CONNECTING ROD (Continued)

- 7 Disassemble connecting rod carefully insert bearing halves (8). The bottom half has a hole which fits into connecting rod cup. Reassemble connecting rod with two hexagon socket head cap screws. Tighten screws following procedures described in preceding step 5.
- 8 Measure inside diameter of bearing. Measure at points 1 and 2 along axis A and B. Measurements should be 1.6541 to 1.6525 inches (42.016 to 41.974 mm).
- 9 If any measurement is outside the tolerance limits, replace the bearing. Make sure that measurements for points 1 and 2 are not different nor outside the tolerance limits, indicating that bearing is wearing in a conical shape.
- 10 Make sure measurements along axis A and B are not different nor outside tolerance limits, indicating bearing is wearing in an oval shape.
- 11 If bearing is out of-round, replace R. Follow procedure described in paragraph 6-8. Also check cylinder and piston for unusual wear. Follow procedures described in paragraphs 5-11 and 5-12.

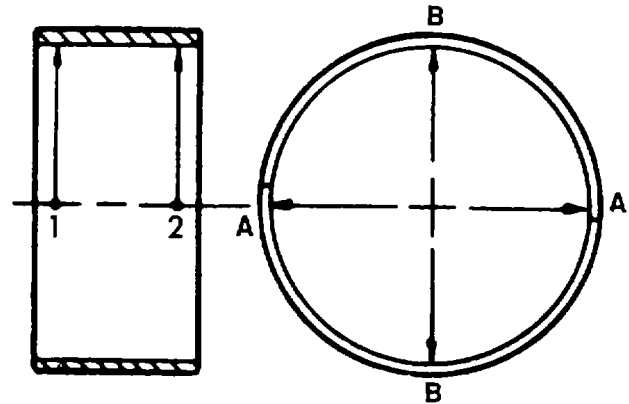

REPAIR:



Dry cleaning solvent P-D-680 (safety or Stoddard's Solvent) is potentially dangerous. Avoid repeated and prolonged breathing of vapors and skin contact with the liquid. Do not use near open flame, arcing equipment, or other ignition sources. Always wear eye protection and protective clothing. The flash point of P-D680 is 100°F to 138°F (38°C to 59°C).

Death or serious injury could occur if compressed air is directed against the skin. Do not use compressed air for cleaning or drying unless the pressure is/has been reduced to 30 psi (2.06 bar) or less. When working with compressed air always use chip guards, eye protection, and other personal equipment.

- 1 Clean rod bushing (1) and connecting rod (2) bore with dry cleaning solvent and dry with compressed air.

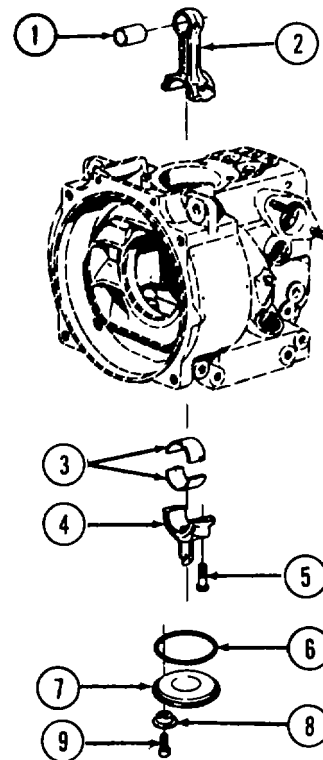

6-3. REPAIR/REPLACE CONNECTING ROD (Continued)

- 2 Inspect rod bushing (1) for scoring, overheating, or other damage. Replace if damaged.
- 3 Measure inside diameter of rod bushing (1). Measurement should be 1.104 to 1.103 inches (28.048 to 28.035 mm). If measurement is outside specified limits, replace rod bushing.

CAUTION

Be certain that the numbers on both halves of the connecting rod match.

NOTE

Clean rust preventive from replacement connecting rod. Also make sure bearing bore is thoroughly cleaned to prevent trapped contaminants from adversely affecting bearings.

- 4 If required, clamp connecting rod in a padded vise and install new rod bushing (1) into connecting rod bushing bore.

INSTALLATION:**CAUTION**

Be certain that bearing halves are installed correctly. The bottom bearing half (3) has a hole which fits into lower connecting rod half (4).

- 1 Carefully insert bearing halves (3) into connecting rod.

CAUTION

Be certain that the numbers on both halves of the connecting rod match.

When installing connecting rod, make sure it does not knock against crankcase. This could result in serious damage to connecting rod.

- 2 Install top half of connecting rod (2) on crankshaft.
- 3 Install bottom half of connecting rod (4) (with dipper opening to dipstick side) and hexagon socket head cap screws (5). Tighten screws to 29.50 foot-pounds (40 N-m).
- 4 Lubricate preformed packing (6) with lubricating oil and install into cover (7).
- 5 Install cover (1) with four caps (8) and hexagon socket head cap screws (9).

6-4. REPAIR/REPLACE TIMING COVER AND CAMSHAFT

This task covers: a. Removal c. Disassembly e. Assembly
 b. Cleaning d. Repair f. Installation

INITIAL SETUP**Tools**

Tool Kit, General Mechanics Automotive
 (Item 1, Appendix B)

Extractor, Cam Follower Spindle
 (Item 3, Appendix B)

Mounting Device, Camshaft Needle Bearing
 (Item 3, Appendix B)

Punch, Camshaft Needle Bearing
 (Item 3, Appendix B)

Equipment Condition Para	Condition Description
---	------------------------------

4-18

Lift pump removed.

5-8

Injection pump removed.

5-9

Crank handle and gears removed.

6-3

Connecting rod removed from
engine.**Materials/Parts**

Dry cleaning solvent (Item 10, Appendix E)

Bushing

Gasket

Ball bearing

Oil seal

General Safety Instructions

Well-ventilated area required.

6-4. REPAIR/REPLACE TIMING COVER AND CAMSHAFT (Continued)

REMOVAL:

CAUTION

Lift both cam followers from camshaft when removing timing cover to prevent bending by cam points.

- 1 Remove four hexagon head screws (1), two hexagon socket head screws (2), and four joints (3) and remove timing cover (4) with assembled bushing (5), oil seal (6), intermediate ring (7) and ball bearing (8). Remove camshaft (9) with assembled hexagon nut (10), wave washer (11), circlip (12), flanged wheel (13), roller bearing (14), and spacer (15). Remove and discard gasket (16).

NOTE

Insertion of hexagon socket head cap screws in timing cover holes may aid in removing of timing cover.

- 2 Matchmark two teeth of camshaft gear and one tooth of crankshaft gear to make sure of proper alignment of gearing when reinstalling timing cover.

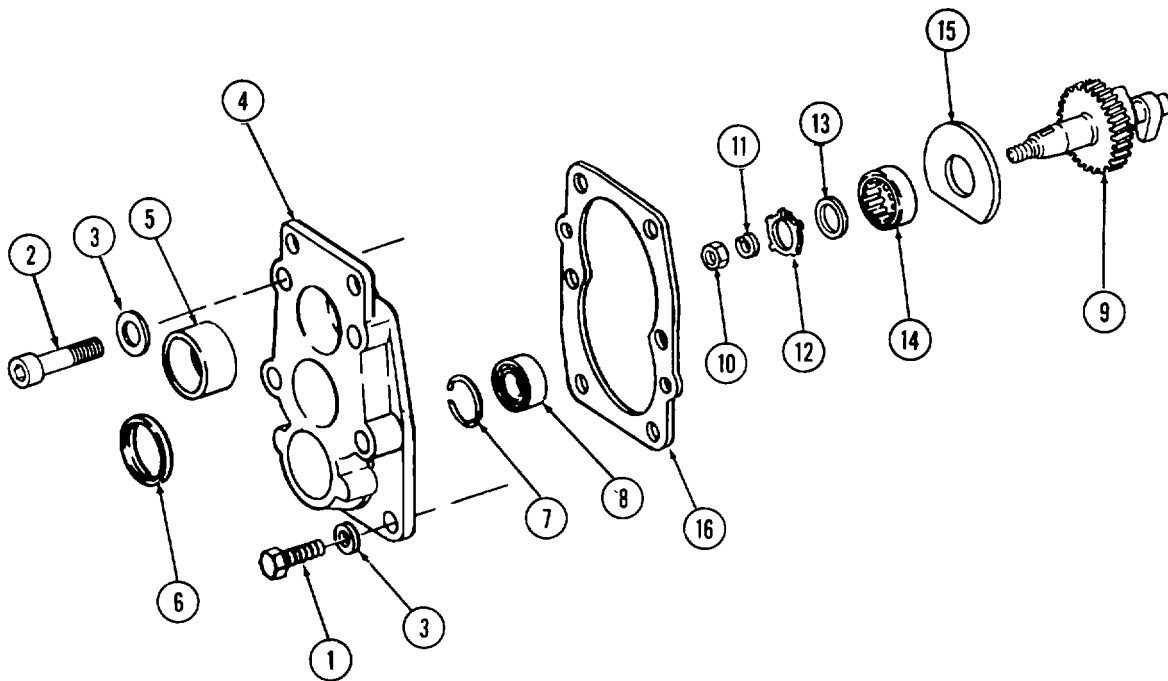

6-4. REPAIR/REPLACE TIMING COVER AND CAMSHAFT (Continued)

- 3 Remove plastic plug (1) above injection pump, and remove hexagon socket head setscrew (2) from crankcase (3).
- 4 Remove spindle (4), cam followers (5 and 6) and shim (7) from crankcase (3) using cam follower spindle extractor.
- 5 Remove needle bearing (8) using camshaft needle bearing punch. If damaged, install new needle bearing using camshaft needle bearing punch.

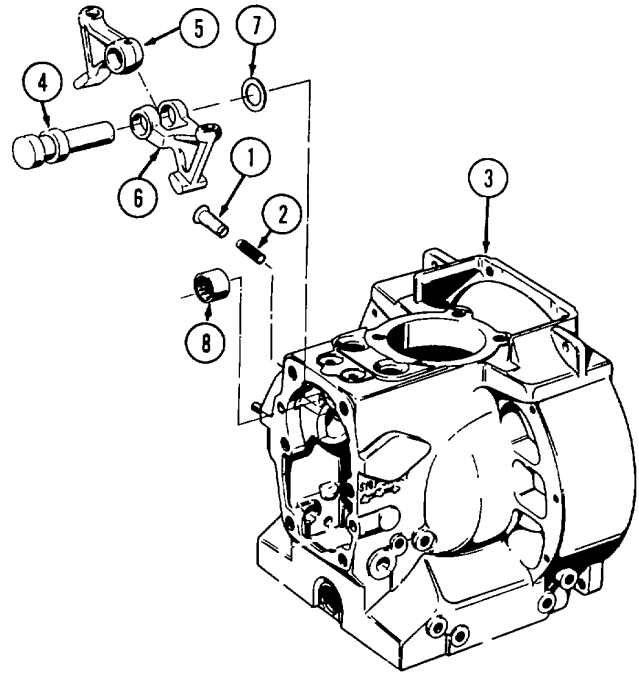
**CLEANING:****WARNING**

Dry cleaning solvent P-D-680 (safety or Stoddard's Solvent) is potentially dangerous. Avoid repeated and prolonged breathing of vapors and skin contact with the liquid. Do not use near open flame, arcing equipment, or other ignition sources. Always wear eye protection and protective clothing. The flash point of P-D-680 is 100°F to 138°F (38°C to 59°C).

Death or serious injury could occur if compressed air is directed against the skin. Do not use compressed air for cleaning or drying unless the pressure is/has been reduced to 30 psi (2.06 bar) or less. When working with compressed air always use chip guards, eye protection, and other personal equipment.

- 1 Clean timing cover with dry cleaning solvent and dry with compressed air.
- 2 Inspect all components for damage or excessive wear. Replace any components severely damaged or worn.
- 3 Inspect surfaces of cam followers. If damaged, replace cam followers.

6-4. REPAIR/REPLACE TIMING COVER AND CAMSHAFT (Continued)

DISASSEMBLY:

- 1 Remove oil seal (6) from timing cover (4). Discard the oil seal
- 2 Collapse bushing (5) and remove. Discard the bushing.

WARNING

Handling heated parts can cause severe burns. Use proper equipment to handle heated parts.

- 3 Heat timing cover (4) to 120° F to 160° F (50°C to 70°C). Remove intermediate ring (7) and drive out ball bearing (8). Discard the ball bearing.
- 4 While timing cover (4) is still hot, drive out camshaft (9).
- 5 Remove hexagon nut (10), wave washer (11), circlip (12), flanged wheel (13), roller bearing (14) and spacer (15).

REPAIR:

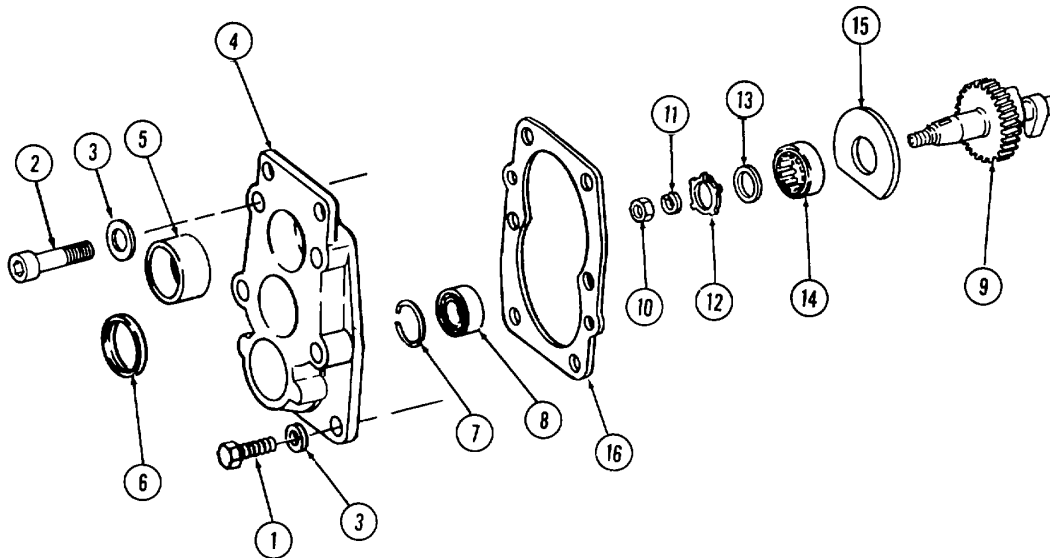

WARNING

Dry cleaning solvent P-D-680 (safety or Stoddard's Solvent) is potentially dangerous. Avoid repeated and prolonged breathing of vapors and skin contact with the liquid. Do not use near open flame, arcing equipment, or other ignition sources. Always wear eye protection and protective clothing. The flash point of P-D-680 is 100°F to 138°F (38°C to 59°C).

Death or serious injury could occur if compressed air is directed against the skin. Do not use compressed air for cleaning or drying unless the pressure is/has been reduced to 30 psi (2.06 bar) or less. When working with compressed air always use chip guards, eye protection, and other personal equipment.

- 1 Clean with dry cleaning solvent and dry with compressed air.
- 2 Repair any minor damage, nicks, burrs, rust, or corrosion.

6-4. REPAIR/REPLACE TIMING COVER AND CAMSHAFT (Continued)

ASSEMBLY:

- 1 Assemble spacer (15), roller bearing (14), flanged wheel (13), circlip (12), wave washer (11), and hexagon nut (10) onto camshaft (9).

WARNING

Handling heated parts can cause severe burns. Use proper equipment to handle heated parts.

- 2 Heat timing cover (4) to 120°F to 160° F (50° C to 70° C). Press in new ball bearing (8) and install intermediate ring (7).
- 3 While timing cover (4) is still hot, press in camshaft (9).

- 4 Press in new bushing (5).
- 5 Install new oil seal (6).
- 6 Install cam followers (17 and 18) and shim (19) on spindle (20). Press spindle into crankcase (21) and secure with setscrew (22) installed above injection pump. Install plastic plug (23) in crankcase over setscrew.

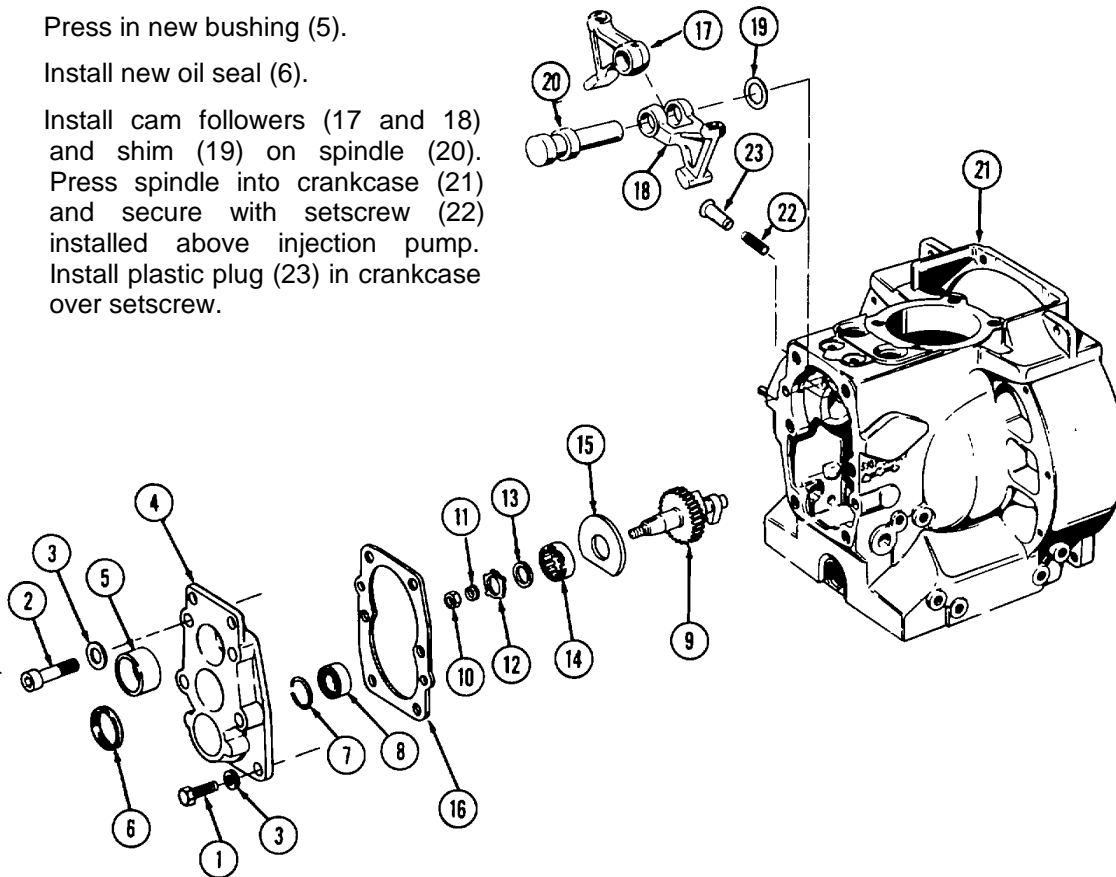

INSTALLATION:

- 1 Install timing cover (4) using a new gasket (16).

NOTE

Make sure matchmarks on camshaft gear and crankshaft gear are aligned.

- 2 Install four hexagon head cap screws (1), two hexagon socket headcap screws (2) and joints (3).

6-5. REPAIR/REPLACE GOVERNOR

This task covers: a. Removal c. Inspection
 b. Cleaning

INITIAL SETUP

Tools

Tool Kit, General Mechanics Automotive
 (Item 1, Appendix B)

Extractor For Gear, Crankshaft
 (Item 3, Appendix B)

Impact Mandrel, Gear On Crankshaft
 (Item 3, Appendix B)

Special Tool For Governor Spring
 (Item 3, Appendix B)

**Equipment
 Condition
 Para**

6-4

Condition Description

Timing cover and camshaft removed
 from engine

General Safety Instructions

Well-ventilated area required.

Material/Parts

Dry cleaning compound (Item 10, Appendix E)
 Grease (Item 3, Appendix E)
 Lubricating oil (Item 6, Appendix E)
 Prefomed packings

REMOVAL:

- 1 Remove gearwheel (1) from crankshaft.
- 2 Remove pins (2 and 3) from shaft (16).
- 3 Remove threaded pin (4) and hexagon nut (5) from governor lever (6).
- 4 Remove two hexagon nuts (7) and lever (8).
- 5 Remove hexagon nut (9) and friction disc (10).
- 6 Press out shaft (16) from crankcase.
- 7 Remove capsule (11), hexagon nut (12), plate (13) and eccentric pin (14). Remove and discard preformed packing (15).

6-5. REPAIR/REPLACE GOVERNOR (Continued)

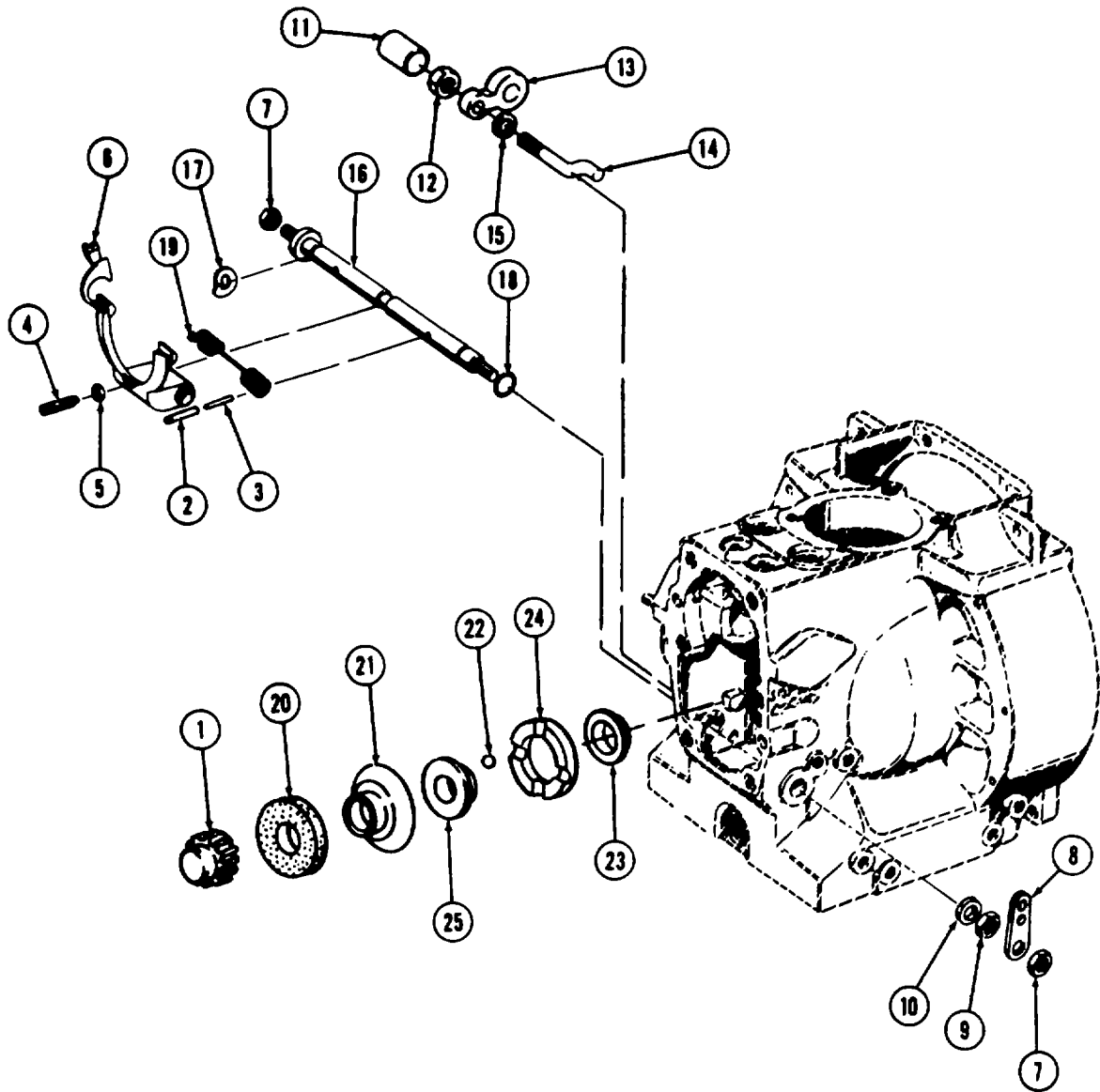

6-5. REPAIR/REPLACE GOVERNOR (Continued)

- 8 Remove wave washer (17), and remove and discard two preformed packings (18).
- 9 Remove governor lever (6) and governor spring (19) from crankcase.
- 10 Pull sliding disc (20) and ball shell (21) from crankshaft.

NOTE

Ball hub disc (23), ball hub (24) and spacer (25) are removed when the crankshaft is removed. Refer to paragraph 6-7 for instructions.

CLEANING:

WARNING

Dry cleaning solvent P-D-680 (safety or Stoddard's Solvent) is potentially dangerous. Avoid repeated and prolonged breathing of vapors and skin contact with the liquid. Do not use near open flame, arcing equipment, or other ignition sources. Always wear eye protection and protective clothing. The flash point of P-D-680 is 100°F to 138°F (38°C to 59°C).

Death or serious injury could occur if compressed air is directed against the skin. Do not use compressed air for cleaning or drying unless the pressure is/has been reduced to 30 psi (2.06 bar) or less. When working with compressed air always use chip guards, eye protection, and other personal equipment.

- 1 Clean all parts with dry cleaning solvent and dry with compressed air.
- 2 Inspect all components for damage or excessive wear. Replace any components severely damaged or worn.

INSTALLATION:

- 1 If any of the four balls (22) were removed during disassembly, apply grease to four balls (22) and install balls in ball hub (24).

CAUTION

Ball shell (21) must slide easily over the crankshaft. Damage to crankshaft and governor could result from improper fitting of governor parts.

- 2 Slide ball shell (21) and sliding disc (20) onto crankshaft.
- 3 Lubricate new preformed packing (15) with lubricating oil and install in preformed packing groove on eccentric pin (14).

6-5. REPAIR/REPLACE GOVERNOR (Continued)

- 4 Install eccentric pin (14), plate (13), hexagon nut (12) and capsule (11) into crankcase.
- 5 Mount governor spring (19) on governor lever (6) and install both parts into crankcase.

NOTE

The loop hole of the governor spring should point upward.

- 6 Lubricate two new preformed packings (18) with lubricating oil and install in preformed packing grooves on shaft (16).
- 7 Slide wave washer (17) on shaft (16) and install into crankcase.

CAUTION

Governor lever and shaft should move freely. Do not overtighten threaded pin and lock lever on shaft. (Snug pin to bottom and unscrew 1/2 turn.)

- 8 Drive pins (2 and 3) through shaft until approximately 0.125 inch (3.21 mm) of roll pins protrude through reverse side of shaft (16). Loop ends of governor spring through drive pins (2 and 3).
- 9 Drive pins (2 and 3) in shaft (16) until flush with shaft.
- 10 Screw threaded pin (4) into governor lever (6) and tighten hexagon nut (5).
- 11 Install friction disc (10), hexagon nut (9), lever (8), and two hexagon nuts (7) on shaft (16).

WARNING

Handling heated parts can cause severe burns. Use proper equipment to handle heated parts.

- 12 Heat timing gearwheel (1) to 160° to 1750 F (70° to 80° C). Install gearwheel onto crankshaft.
-

6-6. REPLACE OIL SEAL (FLYWHEEL SIDE)

This task covers: a. Removal c. Installation
 b. Cleaning/Inspection

INITIAL SETUP

Tools

Tool Kit, General Mechanics Automotive
(Item 1, Appendix B)

**Equipment
Condition
Para**

Condition Description

5-13 Flywheel removed from engine.

Materials/Parts

Grease (Item 3, Appendix E)
Preformed packing

General Safety Instructions

Well-ventilated area required.

REMOVAL:

- 1 Remove support (1) by removing two security plates (2) and four hexagon head cap screws (3). Remove and discard preformed packing (4).
- 2 Remove oil seal (5).

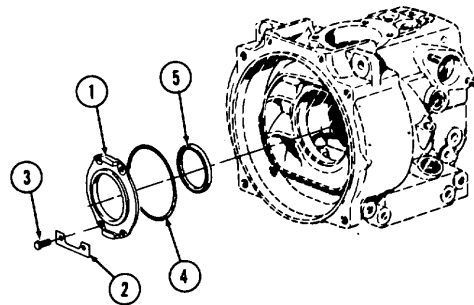

6-6. REPLACE OIL SEAL (FLYWHEEL SIDE) (Continued)

CLEANING/INSPECTION:**WARNING**

Dry cleaning solvent P-D-680 (safety or Stoddard's Solvent) is potentially dangerous. Avoid repeated and prolonged breathing of vapors and skin contact with the liquid. Do not use near open flame, arcing equipment, or other ignition sources. Always wear eye protection and protective clothing. The flash point of P-D-680 is 100°F to 138°F (38°C to 59°C).

Death or serious injury could occur if compressed air is directed against the skin. Do not use compressed air for cleaning or drying unless the pressure is/has been reduced to 30 psi (2.06 bar) or less. When working with compressed air always use chip guards, eye protection, and other personal equipment.

- 1 Clean oil seal components with dry cleaning solvent and dry with compressed air.
- 2 Inspect all components for damage or excessive wear. Replace any components severely damaged or worn.

INSTALLATION:

- 1 Install oil seal (5) into support (1).
 - 2 Fill groove of oil seal (5) with grease.
 - 3 Lubricate new preformed packing (4) with grease and install i in preformed packing groove in support.
 - 4 Install support (1) onto crankshaft with two security plates (2) and four hexagon head cap screws (3).
-

6-7. REPLACE CRANKSHAFT

This task covers: a. Removal c. Cleaning/inspection e. Installation
 b. Disassembly d. Assembly

INITIAL SETUP

Tools

Tool Kit, General Mechanics Automotive
 (Item 1, Appendix B)

Torque Wrench (Item 3, Appendix B)

Crankshaft Removing Device (Item 3, Appendix B)

Impact Mandrel, Ball Hub (Item 3, Appendix B)

Mounting Device, Crankshaft End Play
 (Item 5, Appendix B)

**Equipment
 Condition**

Para	Condition Description
6-5	Governor removed from engine.
6-6	Oil seal removed from engine.

General Safety Instructions

Well-ventilated area required.

Materials/Parts

Lubricating oil (Item 6, Appendix E)
 Cover

REMOVAL:

WARNING

Handling heated parts can cause severe burns. Use proper equip-ment to handle heated parts.

- 1 Heat crankcase to 175OF to 210F (800C to 1000C). Push out crankshaft (1) and roller bearing outer race (3). Remove key (2).

NOTE

Balls (9), ball shell (10), and sliding disc (11) are governor components. Refer to paragraph 6-5 for instructions on removal of these parts.

- 2 Remove and discard cover (12).

6-7. REPLACE CRANKSHAFT (Continued)

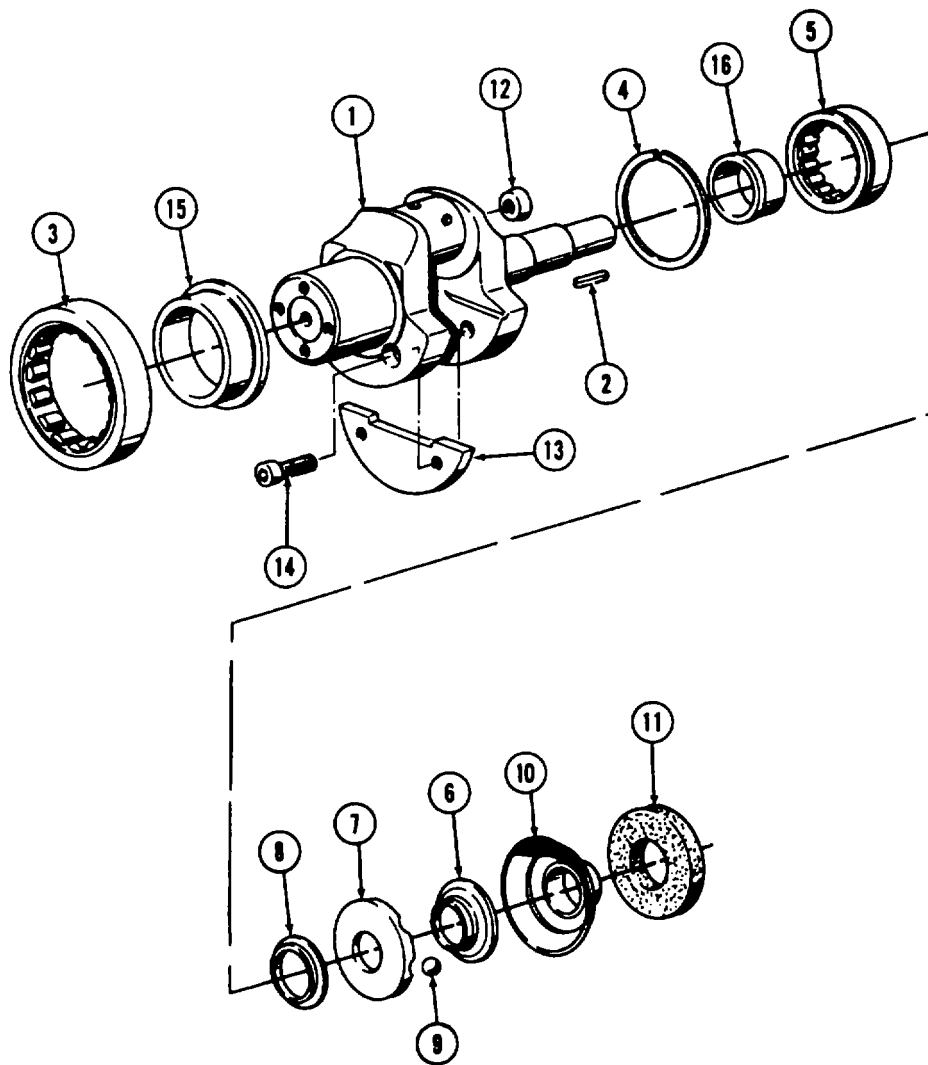

6-7. REPLACE CRANKSHAFT (Continued)

- 3 Remove counterweight (13) by removing two hexagon socket head cap screws (14).

WARNING

Handling heated parts can cause severe burns. Use proper equipment to handle heated parts.

- 4 Heat roller bearing inner races (15 and 16) and remove them from crankshaft (1).

CLEANING/INSPECTION:**WARNING**

Dry cleaning solvent P-D-680 (safety or Stoddard's Solvent) is potentially dangerous. Avoid repeated and prolonged breathing of vapors and skin contact with the liquid. Do not use near open flame, arcing equipment, or other ignition sources. Always wear eye protection and protective clothing. The flash point of P-D-680 is 100°F to 138°F (38°C to 59°C).

Death or serious injury could occur if compressed air is directed against the skin. Do not use compressed air for cleaning or drying unless the pressure is/has been reduced to 30 psi (2.06 bar) or less. When working with compressed air always use chip guards, eye protection, and other personal equipment.

- 1 Clean crankshaft components with dry cleaning solvent and dry with compressed air. Clean oil passages with a stiff wire brush.
- 2 Inspect all components for damage or excessive wear. Replace any components severely damaged or worn.

ASSEMBLY:

- 1 Install new cover (12).
- 2 Apply lubricating oil to the threads of two hexagon socket head cap screws (14) and contact surface of counterweight (13). Install counterweight and two hexagon socket head cap screws. Torque hexagon socket head cap screws to 16 foot-pounds (22 N-m).

WARNING

Handling heated parts can cause severe burns. Use proper equipment to handle heated parts.

- 3 Heat the inner races of roller bearings (15 and 16) to 160°F to 175°F (70°C to 80°C) and press them onto crankshaft (1).

6-7. REPLACE CRANKSHAFT (Continued)

INSTALLATION:

- 1 Install circlip (4) into roller bearing outer race (5) and press bearing race into crankcase until it comes to a stop at the circlip.
- 2 Push roller bearing outer race (3) onto crankshaft (1).
- 3 Install crankcase end play mounting device on crankshaft.

WARNING

Handling heated parts can cause severe burns. Use proper equipment to handle heated parts.

- 4 Heat crankcase (1) to 175°F to 210°F (80°C to 100°C).
- 5 Push in crankshaft (1) and crankcase end play mounting device until mounting device stops. Allow crankcase to cool. Remove mounting device.
- 6 Heat ball hub disc (6), ball hub (7) and spacer (8) to 175°F to 210°F (80°C to 100°C).
- 7 Install spacer (8), ball hub (7) and ball hub disc (6) onto crankshaft.

NOTE

Balls (9), ball shell (10), and sliding disc (11) are governor components. Refer to paragraph 6-5 for Instructions on Installation of these parts.

6-8. REPAIR/REPLACE CRANKCASE

This task covers: a. Removal c. Assembly
 b. Cleaning/Inspection

INITIAL SETUP

Tools

Tool Kit, General Mechanics Automotive
 (Item 1, Appendix B)

**Equipment
 Condition**

Para	Condition Description
6-7	Crankshaft removed from engine.

Materials/Parts

Dry cleaning solvent (Item 10, Appendix E)
 Lubricating oil (Item 6, Appendix E)
 Joint
 Preformed packing

General Safety Instructions

Well-ventilated area required.

DISASSEMBLY:

- 1 Remove oil dipstick (1) from crankcase (2). Remove and discard preformed packing (3).
- 2 Remove oil fill cap (4). Remove and discard preformed packing (5).
- 3 Remove cylinder pin (6).
- 4 Remove oil drain plug (7). Remove and discard joint (8).

6-8. REPAIR/REPLACE CRANKCASE (Continued)

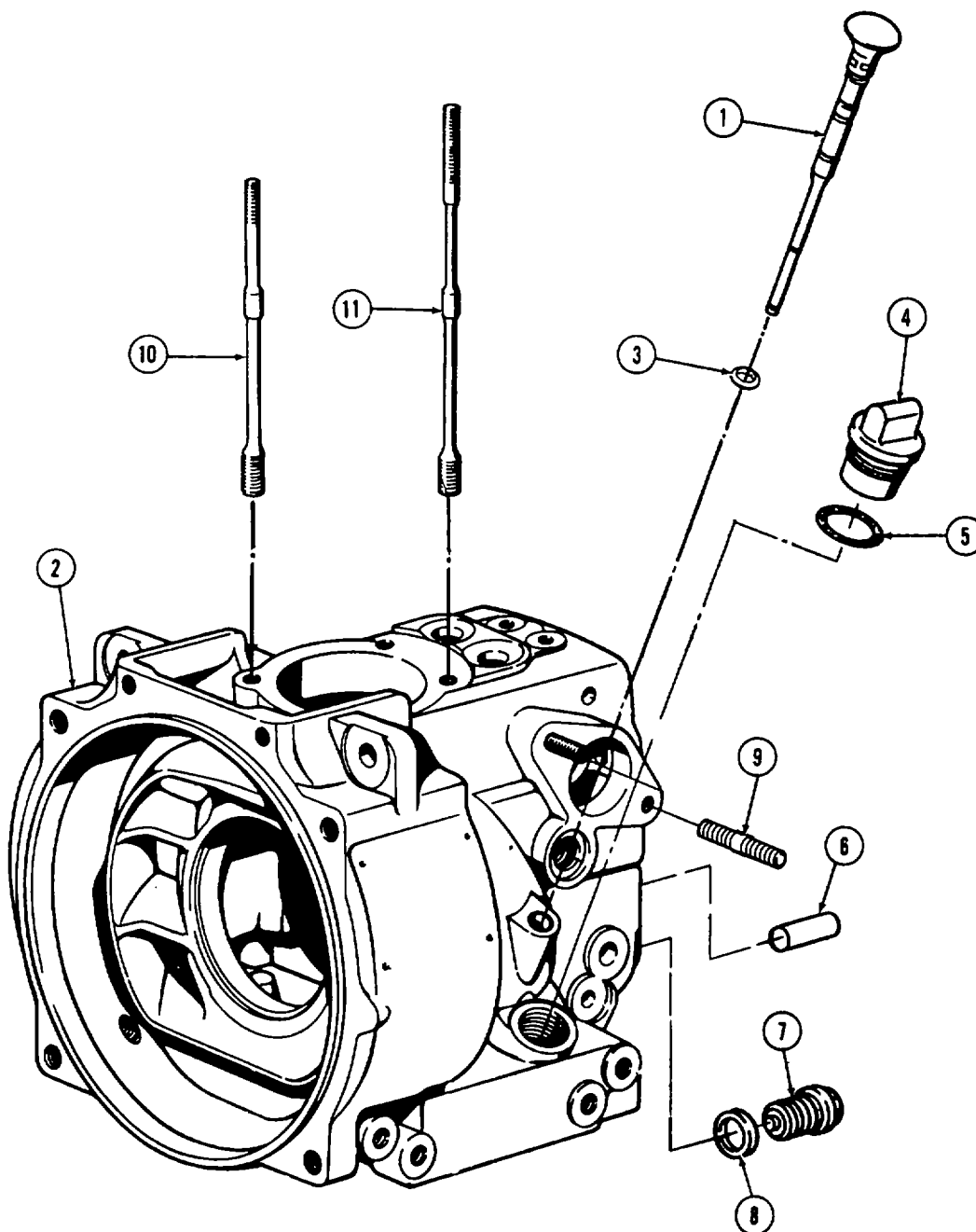

6-8. REPAIR/REPLACE CRANKCASE (Continued)

CLEANING/INSPECTION:**WARNING**

Dry cleaning solvent P-D-680 (safety or Stoddard's Solvent) is potentially dangerous. Avoid repeated and prolonged breathing of vapors and skin contact with the liquid. Do not use near open flame, arcing equipment, or other ignition sources. Always wear eye protection and protective clothing. The flash point of P-D-680 is 100°F to 138°F (38°C to 59°C).

Death or serious injury could occur if compressed air is directed against the skin. Do not use compressed air for cleaning or drying unless the pressure is/has been reduced to 30 psi (2.06 bar) or less. When working with compressed air always use chip guards, eye protection, and other personal equipment.

Live steam used for cleaning shall not exceed 100 psi (6.9 bar). Use goggles or face shield for eye protection. Do not direct live steam against skin.

- 1 Clean crankcase thoroughly with steam cleaner. Clean all exterior openings and surfaces. Be especially sure to clean oil passages to make sure they are clear. Use a small and/or large wire bristle brush where necessary to remove carbon or other deposits from openings and surfaces. Use dry cleaning solvent as necessary to soften and remove carbon or hardened oil deposits. Dry with compressed air.
- 2 Inspect crankcase for any cracks, discoloration, distortion, rust, corrosion, or other damage. If crankcase is cracked, distorted, overheated, seriously rusted or corroded on machined surfaces, or exhibits other serious damage, replace crankcase.
- 3 Inspect two studs (9), two studs (10), and two studs (11) for thread damage. If damaged, replace studs.

ASSEMBLY:

- 1 Lubricate new joint (8) with lubricating oil and install on oil drain plug (7). Install oil drain plug.
 - 2 Install cylinder pin (6).
 - 3 Lubricate new preformed packing (5) with lubricating oil and install on oil fill cap (4). install oil fill cap.
 - 4 Lubricate new preformed packing (3) with lubricating oil and install on dipstick (1). Install oil dipstick in crankcase (2).
-

6-9. REPLACE/ADJUST INJECTION PUMP

This task covers:	a. Removal	c. Adjustment
	b. Installation	

INITIAL SETUP

Tools

- Tool Kit, General Mechanics Automotive (Item 1, Appendix B)
- Dial Gauge (Item 3, Appendix B)
- Socket Wrench, 30 mm (Item 3, Appendix B)
- Special Wrench (Item 3, Appendix B)
- Extra Fuel Device (Item 3, Appendix B)
- "C" Clamp (Item 3, Appendix B)

Equipment Condition

Para	Condition Description
4-13	Pump housing assembly removed.
4-17	Fuel hose and pressure line removed.

General Safety Instructions

Well-ventilated area required.

Materials/Parts

- Dry cleaning solvent (Item 10, Appendix E)
- RTV Sealant (Item 11, Appendix E)

REMOVAL:

- 1 Move throttle control hand lever to the left past stop and pull extra fuel button.

CAUTION

Do not scratch or mar mating surfaces of injection pump or mounting surface. The pump may leak or otherwise malfunction after reassembly.

- 2 Remove two hexagon nuts (1) and remove fuel injection pump (2).

NOTE

Be careful not to drop plate (4) into engine crankcase when removing.

- 3 Remove shim(s) (3), plate (4), and tappet (5).

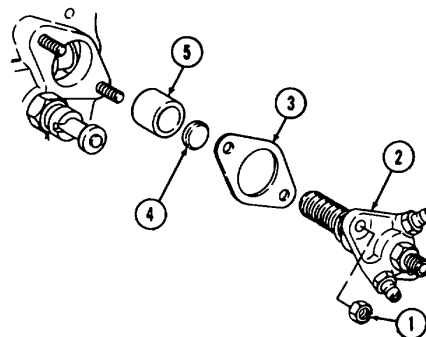

6-9. REPLACE/ADJUST INJECTION PUMP (Continued)**WARNING**

Dry cleaning solvent P-D-680 (safety or Stoddard's Solvent) is potentially dangerous. Avoid repeated and prolonged breathing of vapors and skin contact with the liquid. Do not use near open flame, arcing equipment, or other ignition sources. Always wear eye protection and protective clothing. The flash point of P-D-680 is 100°F to 138°F (38°C to 59°C).

Death or serious injury could occur if compressed air is directed against the skin. Do not use compressed air for cleaning or drying unless the pressure is/has been reduced to 30 psi (2.06 bar) or less. When working with compressed air always use chip guards, eye protection, and other personal equipment.

- 4 Clean all parts with clean dry cleaning solvent and dry with low pressure compressed air.
- 5 Inspect mating surface of injection pump for roughness or other damage. Scratches or other damage may result in pressure leaks. Check wear at contact areas. Replace injection pump if worn.

INSTALLATION:

- 1 Install tappet (1) into crankcase (2).
- 2 Turn engine by hand until tappet (1) reaches the lowest point of cam (3).
- 3 Position throttle control hand lever so that governor lever (4) slot lies exactly in the center of the tappet bore.
- 4 Install plate (5), with the flat surface toward injection pump (7).
- 5 Place shim pack (6) on crankcase (2) studs.
- 6 Apply a bead of RTV sealant around injection pump (7) mating surface.
- 7 Position control sleeve on injection pump (7) so that control sleeve pin enters slot in governor lever (4).
- 8 Insert injection pump (7) carefully without moving the control sleeve out of its proper position.

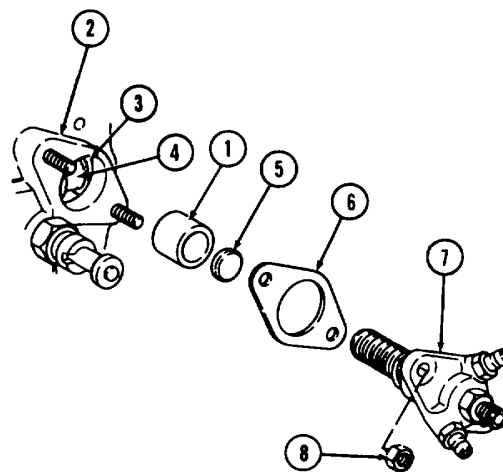
**NOTE**

No resistance should be felt until the pump is within 0.160 Inch (4 mm) of the crankcase, then a resistance due to initial load of plunger spring can be felt.

6-9. REPLACE/ADJUST INJECTION PUMP (Continued)**CAUTION**

Do not tighten pump if not seated properly. Damage to pump, governor lever, or engine could result if improperly installed.

- 9 Using hand pressure, insert injection pump (7) fully into crankcase(2) and install two hexagon nuts (8). If the pump does not seat properly, governor pin sleeve of injection pump has not entered slot (4) in governor lever.

ADJUSTMENTS:

WARNING

Death or serious injury could occur if fuel is not handled carefully. Use in a well-ventilated area away from open flame, arcing equipment, ignition sources, heaters, or excessive heat. Engine must be turned off and cool before refueling. Always store fuel in properly marked containers. DO NOT SMOKE.

CAUTION

When adjusting timing, give special attention to rotation of engine. Timing can be accomplished only when engine is rotated correctly. Correct rotation is clockwise when facing throttle control hand lever.

Preparation:

- 1 Remove engine adapter housing to expose engine flywheel (para 5-13).
- 2 Block fuel hose (fuel tank to fuel lift pump) with a C- clamp.
- 3 Remove the fuel filter, fuel hoses, and clamps using REMOVAL steps 1 thru 7 in paragraph 4-17.
- 4 Disconnect fuel hose (fuel tank to fuel lift pump) from fuel lift pump connection using REMOVAL step 8 in paragraph 4-17.

NOTE

Use the existing fuel filter for testing.

- 5 Install fuel hose (1) (fuel tank to fuel lift pump) to fuel filter (2) inlet. Install fuel filter and connect fuel hose (3) (fuel filter outlet to injection pump).

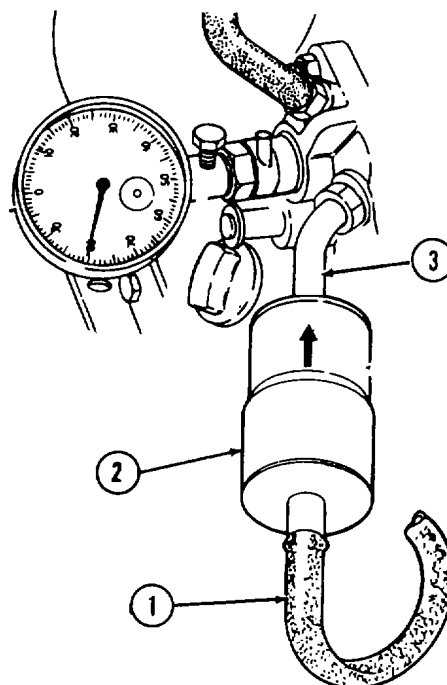

6-9. REPLACE/ADJUST INJECTION PUMP (Continued)

- 6 Unscrew delivery valve holder (1) and remove spring (2) filling piece with three shims (3), copper washer (4), delivery valve (5) and delivery valve body (6).
- 7 Insert copper washer (4) and delivery valve body (6) only into extra fuel device.

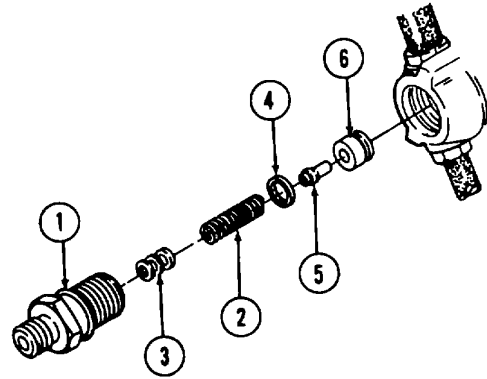

- 8 Thread extra fuel device (1) into injection pump with fuel pipe (2) on extra fuel device in 3 o'clock position, and then secure in place.
- 9 Install dial indicator (3) with adapter pin 1.64-inch (41 mm) long attached, into extra fuel device (1) and pre-tension approximately 1 mm (one rotation of dial indicator hand).
- 10 Remove C-clamp from fuel hose.

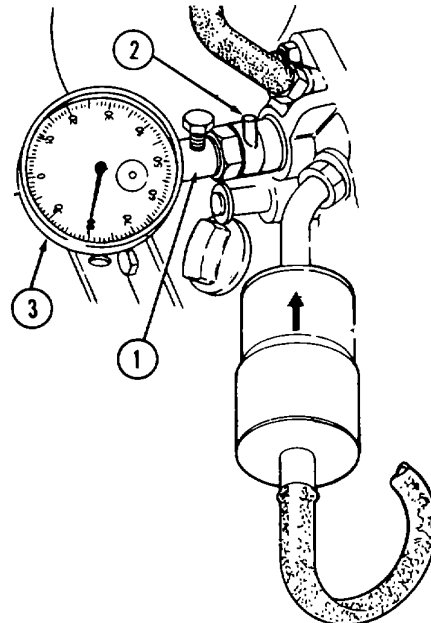

NOTE

Fuel emerging from the fuel pipe on extra fuel device must be bubble free.

- 11 Move throttle control hand lever to the left past stop.
- 12 Install hand crank.

Adjustment of Delivery End:

NOTE

The position of TDC (2) and end of delivery (3) is marked on the flywheel. The corresponding alignment mark (4) is on the right upper side of the crankcase.

- 1 Slowly rotate flywheel counterclockwise (when facing flywheel) until no fuel emerges from fuel pipe on extra fuel device.
- 2 Continue to very slowly rotate flywheel, while frequently blotting fuel pipe with rag to absorb fuel, until fuel just begins to weep from fuel pipe.

6-9. REPLACE/ADJUST INJECTION PUMP (Continued)

NOTE

The position achieved above is the end of delivery. If the shim pack is of the correct thickness, the timing marks on flywheel (1) (11.5 to 12.5 degrees) should align with reference mark (4).

- 3 Block fuel hose (from fuel tank) using a C-clamp.
- 4 If timing marks do not align with reference mark (4), rotate outer face of dial gauge until "0" mark aligns with needle.
- 5 Slowly rotate flywheel (1) in either direction to align timing marks of 11.5 to 12.5 degrees with reference mark (4). Gauge reading will indicate amount of reshimming (as necessary).

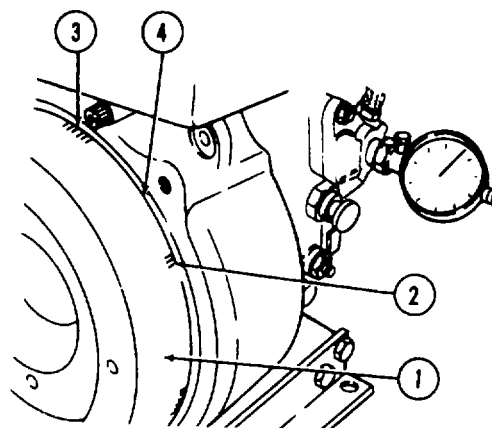
**NOTE**

The end of delivery is delayed or advanced by adding or removing shims (1) to Injection pump (2). The general rule for shimming is as follows:

More shims = end of delivery later (lower number of degrees).
Less shims = end of delivery earlier (higher number of degrees).

- 6 Remove C-clamp from fuel hose.
- 7 After correction of shimming, repeat steps 1 and 2 for checking purposes.

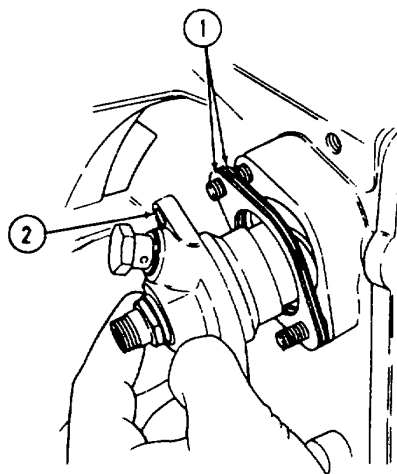

6-9. REPLACE/ADJUST INJECTION PUMP (Continued)Adjustment of Delivery Lift:**NOTE**

Delivery lift controls the quantity of fuel which is injected at full throttle (full load).

- 1 With flywheel timing marks (2) (11.5 to 12.5 degrees) aligned with reference mark (3), rotate dial gauge face to zero.
- 2 Slowly rotate flywheel (1) in a clockwise direction, when facing flywheel, until dial gauge indicates 0.052 inch (1.34 mm).
- 3 Stop flywheel at position indicated in step 2.

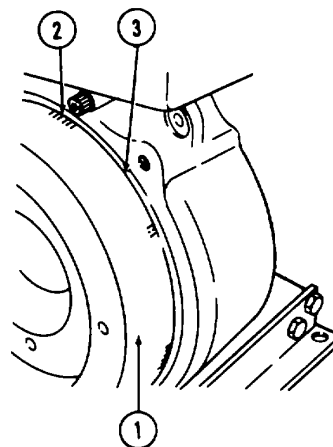
**WARNING**

Death or serious injury could occur if fuel is not handled carefully. Use in a well ventilated area away from open flame, arcing equipment, ignition sources, heaters, or excessive heat. Engine must be turned off and cool before refueling. Always store fuel in properly marked containers. **DO NOT SMOKE.**

- 4 At this point, fuel should emerge again from fuel pipe (1) of extra fuel device (2).

NOTE

If fuel does not emerge, turn the extra fuel device. If the results are not obtained, turn the extra fuel device in the opposite direction.

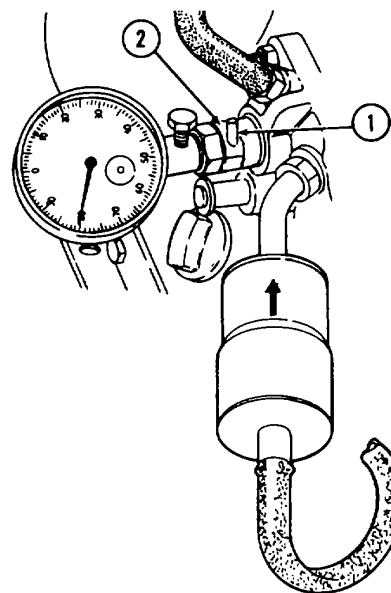

6-9. REPLACE/ADJUST INJECTION PUMP (Continued)

- 5 Loosen extra fuel button hexagon jam nut (2) with socket wrench.
- 6 Slightly rotate extra fuel device (1) until fuel drips at desired rate.
- 7 Tighten extra fuel device hexagon jam nut (2).
- 8 Block fuel hose (from fuel tank) using a C-clamp.
- 9 Remove dial gauge, with extra fuel device attached.

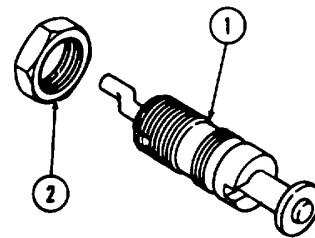

- 10 Remove delivery valve body (1) and copper washer (2).
- 11 Install filling piece with three shims (3) in delivery valve holder (4).
- 12 Insert spring (5) in delivery valve holder (4).
- 13 Insert copper washer (2) in delivery valve holder (4).
- 14 Insert delivery valve (6) in valve body (1).
- 15 Insert delivery valve (6) and valve body (1) into delivery valve holder (4).

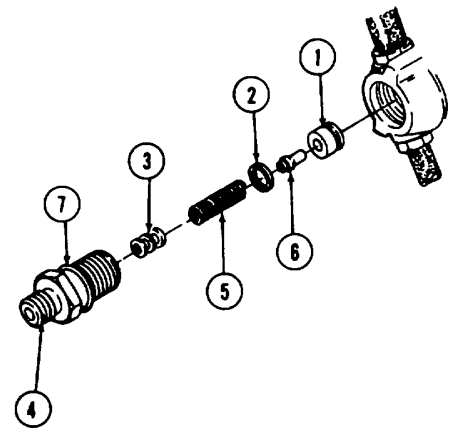

NOTE

Verify that grooved end in the valve body enters the Injection pump opening first.

- 16 Install new preformed packing (7), and then tighten delivery valve holder assembly into injection pump.

6-9. REPLACE/ADJUST INJECTION PUMP (Continued)

WARNING

Before starting the engine and after making repairs or adjustments on the fuel system, a 17 mm wrench must be available to allow rapid removal of the steel fuel line at the injection pump in case of a runaway condition. Failure to heed this warning can result in Injury to personnel and equipment damage.

- 17 Install fuel filter, fuel hoses, and hose clamps as described in INSTALLATION steps 5,6,7,8, and 9 of paragraph 4-17.
 - 18 Remove C-clamp from fuel hose.
 - 19 Install engine adapter housing.
-

**APPENDIX A
REFERENCES**

A-1. PUBLICATIONS INDEX

The following index should be consulted frequently for latest changes or revisions of references given in this appendix and for new publications relating to material covered in this manual.

Index of Administrative Publications..... DA PAM 25-30
 The Army Maintenance Management System (TAMMS) DA PAM 738-750

A-2. FORMS AND RECORDS

Recommended Changes to Publications and Blank Forms..... DA 2028-2
 Equipment Inspection and Maintenance Worksheet..... DA Form 2404
 Equipment Control Record..... DA Form 2408-9
 Packaging Improvement Report..... DD Form 6
 Quality Deficiency Report..... SF 368

A-3. FIELD MANUALS

Operation and Maintenance of Ordnance Material in Cold Weather (0° to -65°F)..... FM 9-207

A-4. TECHNICAL MANUALS

Unit, Direct Support and General Support
 Maintenance Repair Parts and Special Tools List,
 Centrifugal Pump Unit, 100 GPM..... TM 5-4320-310-24P

A-5. TECHNICAL BULLETINS

Hand Portable Fire Extinguishers for Army Users..... TB 5-4320-200-10

APPENDIX B
MAINTENANCE ALLOCATION CHART
Section I INTRODUCTION

B-1. General

a. This section provides a general explanation of all maintenance and repair functions authorized at various maintenance categories.

b. The Maintenance Allocation Chart (MAC) in Section II designates overall authority and responsibility for the performance of maintenance functions on the identified end item or component. The application of the maintenance functions to the end item or component will be consistent with the capacities and capabilities of the designated maintenance categories.

c. Section III lists the tools and test equipment (both special tools and common tool sets) required for each maintenance function as referenced from Section II.

d. Section IV contains supplemental instructions and explanatory notes for a particular maintenance function.

B-2. Maintenance Functions. Maintenance functions will be limited to and defined as follows:

Maintenance functions will be limited to and defined as follows:

a. Inspect. To determine the serviceability of an item by comparing its physical, mechanical, and/or electrical characteristics with established standards through examination (e.g. by sight, sound, or feel).

b. Test. To verify serviceability by measuring the mechanical, pneumatic, hydraulic, or electrical characteristics of an item and comparing those characteristics with prescribed standards.

c. Service. Operations required periodically to keep an item in proper operating condition, i.e., to clean (includes decontaminate, when required), to preserve, to drain, to paint, or to replenish fuel, lubricants, chemical fluids, or gases.

d. Adjust. To maintain or regulate within prescribed limits, by bringing into proper or exact position, or by setting the operating characteristics to specified parameters.

e. Align. To adjust specified variable elements of an item to bring about optimum or desired performance.

f. Calibrate. To determine and cause corrections to be made or to be adjusted on instruments or test, measuring, and diagnostic equipment used in precision measurement. Consists of comparison of two instruments, one of which is a certified standard of known accuracy, to detect and adjust any discrepancy in the accuracy of the instrument being compared.

g. Remove/Install. To remove and install the same item when required to perform service or other maintenance functions. Install may be the act of emplacing, seating, or fixing into position a spare, repair part, or module (component or assembly) in a manner to allow proper functioning of an equipment or system.

h. Replace. To remove an unserviceable item and install a serviceable counterpart in its place. "Replace" is authorized by the MAC and is shown as the third position code of the SMR code.

i. Repair. The application of maintenance services,¹ including fault location/troubleshooting,² removal/installation, and disassembly/assembly procedures,³ and maintenance actions,⁴ to identify troubles and restore serviceability to an item by correcting specific damage, fault, malfunction, or failure in a part, subassembly, module (component or assembly), end item, or system.

j. Overhaul. That maintenance effort (service/action) prescribed to restore an item to a completely serviceable/operational condition as required by maintenance standards in appropriate technical publications (i.e., DMWR). Overhaul is normally the highest degree of maintenance performed by the Army. Overhaul does not normally return an item to like-new condition.

k. Rebuild. Consists of those services/actions necessary for the restoration of unserviceable equipment to a like-new condition in accordance with original manufacturing standards. Rebuild is the highest degree of material maintenance applied to Army equipment. The rebuild operation includes the act of returning to zero those age measurements (hours/miles, etc.) considered in classifying Army equipment/components.

B-3. Explanation Of Columns In The MAC, Section II.

a. Column (1), Group Number. Column 1 lists functional group code numbers, the purpose of which is to identify maintenance significant components, assemblies, subassemblies, and modules with the next higher assembly. End item group number shall be "00".

b. Column (2), Component/Assembly. Column 2 contains the item names of components, assemblies, subassemblies, and modules for which maintenance is authorized.

c. Column (3), Maintenance Function. Column 3 lists the functions to be performed on item listed in column 2. (For a detailed explanation of these functions, see paragraph B-2.)

d. Column (4), Maintenance Category. Column 4 specifies, by the listing of a work time figure in the appropriate subcolumn(s), the category of maintenance authorized to perform the function listed in column 3. This figure represents the active time required to perform the maintenance function at the indicated category of maintenance. If the number or complexity of tasks within the listed maintenance function vary at different maintenance categories, appropriate work time figures will be shown for each category. The work time figure represents the average time required to restore an item (assembly, subassembly, component, module, end item, or system) to a serviceable condition under typical field operating conditions. This time includes preparation time (including any necessary disassembly/assembly time), troubleshooting/fault location time, and quality assurance/quality control time in addition to the time required to perform the specific tasks identified for the maintenance functions authorized in the maintenance allocation chart. The symbol designations for the various maintenance categories are as follows:

¹ Services - Inspect, test, service, adjust, align, calibrate, and/or replace.

² Fault locate/troubleshoot the process of investigating and detecting the cause of equipment malfunctioning; the act of isolating a fault within a system or unit under test (UUT).

³ Disassemble/assemble - encompasses the step-by-step taking apart (or breakdown) of a spare/functional group coded item to the level of its least component identified as maintenance significant (i.e., assigned an SMR code) for the category of maintenance under consideration.

⁴ Actions - welding, grinding, riveting, straightening, facing, remachining, and/or resurfacing.

- C Operator/Crew
- O Unit Maintenance
- F Direct Support Maintenance
- H General Support Maintenance
- D Depot Maintenance

e. Column (5), Tools and Equipment. Column 5 specifies, by code, those common tool sets (not individual tools) and special tools, TMDE, and support equipment required to perform the designated function.

f. Column (6), Remarks. This column shall, when applicable, contain letter code, in alphabetic order, which shall be keyed to the remarks contained in Section IV.

B-4. Explanation Of Columns In Tool And Test Equipment Requirements, Section III.

a. Column (1), Reference Code. The tool or test equipment reference code which correlates with a code used in the MAC, Section II, column 5.

b. Column (2), Maintenance Category. The lowest category of maintenance authorized to use the tool or test equipment.

c. Column (3), Nomenclature. Name or identification of the tool or test equipment.

d. Column (4), National Stock Number. The national stock number of the tool or test equipment.

e. Column (5), Tool Numbers The manufacturer's part number.

B-5. Explanation Of Columns In Remarks, Section IV.

a. Column (1), Reference Code. The code recorded in column 6, Section II.

b. Column (2), Remarks. This column lists information pertinent to the maintenance function being performed as indicated in the MAC, Section II.

**Section II MAINTENANCE ALLOCATION CHART
PUMP UNIT, FLAMMABLE LIQUID, CENTRIFUGAL,
SELF-PRIMING, 2-INCH, 100 GPM, DIESEL ENGINE DRIVEN**

(1) GROUP NUMBER	(2) COMPONENT ASSEMBLY	(3) MAINTENANCE FUNCTION	MAINTENANCE LEVEL					(5) TOOLS AND EQUIP.	(6) REMARKS
			UNIT		DS	GS	DEPOT		
			C	O	F	H	D		
00	Pump Unit								
01	Pump Assembly								
	Backhead	Inspect Replace	0.1	1.0				1	
	Impeller Assembly	Inspect Replace Repair		0.5 1.0	1.0			1	B
	Diffuser Assembly	Inspect Replace Repair		0.5 1.0	1.0			1	B
	Shaft Seal	Inspect Replace		1.0 1.0				1	
	Stub Shaft	Inspect Replace		1.0 1.5				3	
	Housing Assembly	Inspect Replace Repair	1.0	1.0	3.0		2		B
02	Air Filter Assembly	Inspect Service Replace Repair	0.1 0.5	0.5 0.5			2		
	Air Filter Element	Service Replace	0.1 0.1						F
03	Engine Assembly	Inspect Service Replace	0.2 0.2		2.0		2		

**PUMP UNIT, FLAMMABLE LIQUID, CENTRIFUGAL,
SELF-PRIMING, 2-INCH, 100 GPM, DIESEL ENGINE DRIVEN (Continued)**

(1) GROUP NUMBER	(2) COMPONENT ASSEMBLY	(3) MAINTENANCE FUNCTION	MAINTENANCE LEVEL					(5) TOOLS AND EQUIP.	(6) REMARKS
			UNIT		DS	GS	DEPOT		
			C	O	F	H	D		
04	Fuel System Fuel Filter	Inspect	0.1	0.5				1	C,E
		Replace							
	Fuel Lines, Hoses, and Fittings	Inspect	0.1	0.5				1	
		Replace							
	Fuel Lift Pump	Inspect	0.3	0.5	1.5			1	B
		Replace							
		Repair							
Fuel Tank	Inspect	0.2	0.2				1	B	
	Service								
Injector	Inspect	1.0					3	B, G	
	Test								
Injection Pump	Inspect	0.1		2.0	0.1		3	B, E	
	Adjust								
	Test								
05	Exhaust System Muffler	Inspect	0.1	0.1				1	
		Service							
06	Crank Assembly Gears	Inspect			0.5				
		Replace							
06	Handle	Inspect	0.1	0.1					
		Replace							
07	Throttle Throttle Control Hand Lever	Inspect	0.1	0.5				1	A
		Adjust							
		Replace							

**PUMP UNIT, FLAMMABLE LIQUID, CENTRIFUGAL,
SELF-PRIMING, 2-INCH, 100 GPM, DIESEL ENGINE DRIVEN (Continued)**

(1) GROUP NUMBER	(2) COMPONENT ASSEMBLY	(3) MAINTENANCE FUNCTION	MAINTENANCE LEVEL					(5) TOOLS AND EQUIP.	(6) REMARKS
			UNIT		DS	GS	DEPOT		
			C	O	F	H	D		
08	Cylinder Head and Cylinder Assembly								
	Cylinder Head and Valve Assembly	Inspect Adjust Replace Repair		1.0	0.1 3.0	3.0		3	A, B, H, I
	Cylinder	Inspect Replace			0.1 3.0			3	B
08	Piston	Inspect Repair Replace			1.0 3.0 3.0			3	B, J
	09	Crankcase Assembly							
	Connecting Rod	Inspect Repair Replace				1.0 3.0 3.0		3	B, J
09	Timing Cover	Inspect Repair Replace				0.2 1.0 3.0		3	B
	Camshaft	Inspect Repair Replace				1.0 4.0 4.0		3	
	Governor	Inspect Repair Replace				1.0 4.5 4.5		3	B
09	Flywheel	Inspect Replace Repair			1.0 2.0 0.5			4	B
	Oil Seal (Flywheel Side)	Inspect Replace				1.0 2.0			B
	Crankshaft	Inspect Replace				1.0 5.0		3,5	
09	Crankcase	Inspect Replace Repair				1.0 5.0 2.0			

**PUMP UNIT, FLAMMABLE LIQUID, CENTRIFUGAL,
SELF-PRIMING, 2-INCH, 100 GPM, DIESEL ENGINE DRIVEN (Continued)**

(1) GROUP NUMBER	(2) COMPONENT ASSEMBLY	(3) MAINTENANCE FUNCTION	MAINTENANCE LEVEL					(5) TOOLS AND EQUIP.	(6) REMARKS
			UNIT		DS	GS	DEPOT		
			C	O	F	H	D		
10	Frame Assembly Frame	Inspect Repair Replace	0.2		2.5 1.0			D	
	Mounting Bracket	Inspect Replace	0.2		0.5				
	Shock Mount	Inspect Replace	0.2		0.5				

Section III. TOOL AND TEST EQUIPMENT REQUIREMENTS

(1) Tool or Test Equipment Ref Code	(2) Maintenance Category	(3) Nomenclature	(4) National/ NATO Stock Number	(5) Tool Number
1	O	Tool Kit, General Mechanics Automotive	5180-00-177-7033	SC 5180-90-N26
2	O	Shop Equipment, Automotive Maintenance and Repair, Common No.1	4910-00-754-0654	SC4910-95-CL-A74
3	F, H	Shop Set, Automotive, Field Maintenance, Basic	4910-00-754-0705	SC4910-95-CL-A31
4	F, H	Socket for screw with internal serrations		612 099 00
5	H	Mounting device - crankshaft end play		666 074 00

Section IV. REMARKS

(1) Reference Code	(2) Remarks
A	Adjust to specifications
B	Repair by replacing defective components
C	Replace element
D	Weld
E	Repair by bleeding air from the fuel system
F	Service by cleaning filter
G	Test timing and pressure output
H	Includes replacing valve seats, guides, and main bearings
I	Includes replacing bearing, valves, and gears
J	Includes replacing rings and rod bearings

APPENDIX C
COMPONENTS OF END ITEM AND BASIC ISSUE ITEMS LISTS

SECTION I. INTRODUCTION

C-1. SCOPE

This appendix lists components of end item and basic issue items for the centrifugal pump unit to help you inventory items required for safe and efficient operation.

C-2. GENERAL

The components of End Item and Basic Issue Items Lists are divided into the following sections:

a. Section II. Components of End Item. This listing is for informational purposes only, and is not authority to requisition replacements. These items are part of the end item, but are removed and separately packaged for transportation or shipment. As part of the end item, these items must be with the end item whenever it is issued or transferred between property accounts. Illustrations are furnished to assist you in identifying items.

b. Section III. Basic Issue Items. These are the minimum essential items required to place the centrifugal pump unit in operation, to operate it, and to perform emergency repairs. Although shipped separately packaged, BII must be with centrifugal pump unit during operations and whenever it is transferred between property accounts. The illustrations will assist you with hard-to-identify items. This manual is your authority to request/requisition replacement BII, based on TOE/MTOE authorization of the end item.

C-3. EXPLANATION OF COLUMNS

a. Column (1), Illustration Number (Illus. Number). This column indicates the number of the illustration in which the item is shown.

b. Column (2), National Stock Number. Indicates the National stock number assigned to the item and will be used for requisitioning purposes.

c. Column (3), Description. Indicates the Federal item name and, if required, a minimum description to identify and locate the item. The last line for each item indicates the Commercial and Government Entity Code (CAGEC) (in parentheses) followed by the part number.

d. Column (4), Unit of Measure (U/M). Indicates the measure used in performing the actual operational/maintenance function. This measure is expressed by a two-character alphabetical abbreviation (e.g., ea., in., pr).

e. Column (5), Quantity Required (Qty Rqr). Indicates the quantity of the item authorized to be used with/on the equipment.

SECTION II. COMPONENTS OF END ITEM

NOT APPLICABLE

SECTION III. BASIC ISSUE ITEMS

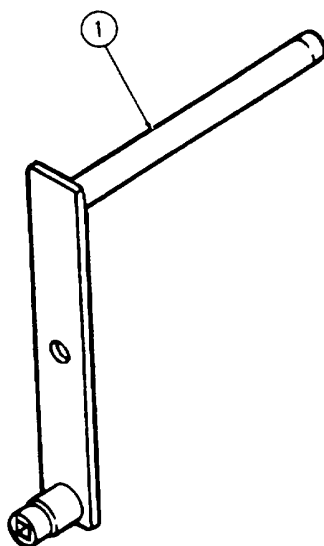

(1) Illus. Number	(2) National Stock Number	(3) Description FSCM and Part Number	Usable On Code	(4) U/M	(5) Qty Rqr
1		TM 10-4320-310-14		EA	1
		HANDLE, STARTING (61080) 003 150 00		EA	1
	4210-00-165-4703	EXTINGUISHER, FIRE		EA	1
	5975-00-878-3791	GROUND ROD ASSEMBLY, SECTIONAL, W/ATTACHMENTS (81349) MIL-R-1 1461		EA	1
	5120-00-449-8083	WRENCH, ADJUSTABLE, 10IN. LG,0-1.135 IN.		EA	1

☆U.S. GOVERNMENT PRINTING OFFICE: 1992 - 755-028/80031

APPENDIX D
ADDITIONAL AUTHORIZATION LIST

NOT APPLICABLE

APPENDIX E

EXPENDABLE/DURABLE SUPPLIES AND MATERIALS LISTS

SECTION I. INTRODUCTION

E-1. SCOPE

This appendix lists expendable/durable supplies and materials you will need to operate and maintain the centrifugal pump unit. These items are authorized to you by CTA 50-970, Expendable items (Except Medical, Class V, Repair Parts, and Heraldic Items).

E-2. EXPLANATION OF COLUMNS

a. Column (1). Item Number. This number is assigned to the entry in the listing and is referenced in the narrative instructions to identify the material (e.g., Dry Cleaning Solvent, Item 11, Appendix E).

b. Column (2). Level. This column identifies the lowest level of maintenance that requires the listed item.

- C - Operator/Crew
- O - Unit Maintenance
- F - Direct Support Maintenance
- H - General Support Maintenance

e. Column (3). National Stock Number. This is the National stock number assigned to the item; use it to request or requisition the item.

c. Column (4). Description. Indicates the Federal item name and, if required, a minimum description to identify and locate the item. The last line for each item indicates the part number followed by the Contractor and Government Entity Code (CAGEC) in parentheses.

d. Column (5). Unit of Measure (U/M). Indicates the measure used in performing the actual maintenance function. If the unit of measure differs from the unit of issue, requisition the lowest unit of measure that will satisfy your requirements.

SECTION II. EXPENDABLE/DURABLE SUPPLIES AND MATERIALS LIST

(1) Item Number	(2) Level	(3) National Stock Number	(4) Description	(5) U/M
1	F		Color, Marking (Dykem)	
2	C, O,F, H		Silicone, MIL-S-8660	gal
3	H	9150-00-190-0907	Grease, Automotive and Artillery, MIL-G-10924	gal
4	O	9150-00-754-2595	Grease, Ball and Roller Bearing, MIL-G-18709	gal
5	H		Lapping and Grinding compound (Valve), 600 grit, A-A-1203	
6	O, F,	9150-186-6681	Oil, Lubricating, Internal Combustion Engine, MIL-L-2104	qt
7	O		Oil, Lubricating, Preservative, MIL-L-21260	qt
8			Preservative Oil, MIL-P-116, Type P-14	qt
9	F		Primer Coating, Zinc Chromate, TT-P-1757	
10	O, F, H	6850-00-274-5421	Solvent, Dry Cleaning, P-D-680	gal
11	F, H		RTV Sealant, MIL-S-45180, Type II	qt

APPENDIX F
ILLUSTRATED LIST OF MANUFACTURED ITEMS

NOT APPLICABLE



GLOSSARY

Section I. ABBREVIATIONS

C.....	Degree Celsius/Centigrade
cm-kg	Centimeter-kilogram
cu.....	Cubic
ea	Each
EIR	Equipment Improvement Recommendations
°F.....	Degree Fahrenheit
ft	Foot; feet
ft-lb	Foot pound
gal	Gallon
gpm	Gallons per minute
hp	Horsepower
in.....	Inch
kg	Kilogram
lb.....	Pound
m ³	Cubic Meter
m-kg	Meter-kilogram
mm	Millimeter
N-m	Newton-meter
NPT	National pipe thread
oz.....	Ounce
PMCS	Preventive maintenance checks and services
psi	Pounds per square inch
qt	Quart
rpm	Revolutions per minute
TDC	Top dead center
TMDE	Test, measurement, and diagnostic equipment

Section II. DEFINITION OF UNUSUAL TERMS

A

ABRASION - A scraped or scuffed area. A hose may become abraded is an unshielded portion of it rubs against a piece of pipe bracket or another hose.

ALIGN - To arrange in a line vertically and/or horizontally.

APPROVED - Permitted to be sued for a specific purpose by the person or group who is authorized to grant approval. ■

ARC - A discharge of electric current crossing a gap between two electrodes.

ASSEMBLY - A combination of parts that may be taken apart without destruction, which has no application or use of its own but is needed for the completeness of a more complex item with which it is combined, or to which it is attached.

B

BRINELLED A deformation of a bearing by an impact.

BUMPING CLEARANCE - Clearance between cylinder head and top of piston. Measured with piston at TDC (top dead center)

C

CAPACITY - The volume, amount, or quantity that can be held or contained.

CARBON MONOXIDE - A poisonous gas that is made while fuel is burning, especially if there is not quite enough air. The gas is colorless, odorless, and tasteless, but it can cause illness and death. See the Warning page at front of manual.

CAVITATION - Condition caused when engine speed is increased beyond point of maximum suction vacuum. Cavitation is indicated by loud cracking noise in pump housing and is harmful to the pump unit.

CHAMFER - A beveled edge.

COMBUSTION - A chemical change, especially oxidation, accompanied by the production of heat and light. A combustion engine functions by burning fuel to produce heat, i.e., energy.

COMPONENT - A part or a combination of parts which together accomplish a function.

COMPRESSED - AIR - Air that is under pressure. When the compressed air in a hose or pipe is allowed to escape (such as when you use an air gun), the air moves very fast and is used to blow away dirt and chips.

CONDENSATION - A liquid formed from a vapor. Moisture carried in warm air will condense when it reaches a cold area, such as the surface of a fuel tank in sub-zero weather.

CORROSION - A gradual wearing away caused by chemical action. Metals exposed to salt water are likely to corrode.

D

DEBRIS - The scattered remains of something broken or destroyed.

DEFLECT - To bend or move from a straight line.

DETERIORATE - A worsening of condition usually as a result of age or hostile environment, as opposed to mechanical damage.

DIAMETRIC - Measurement across the center.

DISPLACEMENT - The volume displaced by a piston in a single stroke.

DISTORTION - The bending, twisting, or any other dynamic change of a surface.

E

EXHAUST - The gases that leave the engine through the tailpipe while engine is running.

EXPENDABLE - An item that is not repairable and is discarded if damaged.

EXPOSURE - Being in the presence of something, or in contact with something. Skin is exposed to cleaning solvent when the solvent contacts the skin during cleaning operations.

F

FILTER - A device which removes dirt from the air or a fluid.

FLASHPOINT - The lowest temperature at which vapors of a solvent will ignite and burn.

FLUID - A substance that can flow; that is either a gas or a liquid.

FRAYED - Something which has been worn away or unraveled, usually by rubbing.

FRETTING - A wearing away or corroding of an area.

G

GASKET - A seal or packing used between matched machine parts or around pipe joints to prevent the escape of gas or fluid.

GOGGLES - A device used to protect the eyes from dust, dirt, flying chips, etc.

GUDGEON PIN - A pivot pin.

I

IMMERSE - To completely cover by fluid.

INHALATION - The act of breathing in. The breathing in or inhalation of carbon monoxide can cause illness or death.

INITIAL - The first or starting condition.

L

LEGIBLE - Capable of being read. A legible nameplate can be read, an illegible plate cannot.

M

MALFUNCTION - Occurs when a unit fails to operate normally.

MANUFACTURER - The company which makes an item or piece of equipment for sale.

MATERIAL - Equipment, apparatus, and supplies of an organization such as an army.

O

OBSTRUCTION - An obstacle

P

PIVOT - A short rod or shaft about which a related part rotates; the act of turning on or as if on a pivot.

PORT - A threaded hole through which fluid may pass, or a pressure may be measured. Ports on the pump are used to connect hoses, and to measure pressure.

PRIME - The act of introducing a liquid into a pump to increase the pump's ability to overcome negative head pressure.

R

RACE - A grooved part of a component, such as a bearing, in which a moving part slides or rolls.

RECOMMENDATIONS - Suggestions for change; advice given usually to make an improvement.

REQUIRE - To demand or need.

RESPIRATION - The process of breathing; inhaling and exhaling.

S

Saturated - Soaked or drenched in liquid.

SCOPE - The extent of an activity or concept; the amount of information covered as in a book.

SCRIBE - Sharp pointed tool.

SEDIMENT - Matter that settles to the bottom of a liquid.

SOLVENT - A liquid that can dissolve another substance.

SYMPTOM - The external sign or indication of a condition.

T

TIEDOWN - Strap or fastening device used to hold an object in position.

TORQUE - Force around an axis. It produces a rotary or twisting motion, and is measured in foot-pounds (ft-lb) or meter-kilograms (m-kg).

V

VALVE - A device used to control the flow of fluid.

VAPOR - The gaseous form of any substance which is usually a liquid; vapors are present in the air around the substance.

VENTILATE - To provide with a source of fresh or uncontaminated air.

VISUAL - Visible; detected by the unaided eye.

ALPHABETICAL INDEX

Subject, Para

A

Abbreviations, 1-8
 Adjustments
 Cylinder Head Clearance, 5-10
 Decompression Mechanism, 4-22, 5-10
 Fuel Injection Timing, 6-9
 Speed, 2-4
 Tappet Clearance, 4-22, 5-10
 Throttle Control, 4-21
 Administrative Storage, 4-24
 Air Filter Assembly, 4-15
 Air Filter Element, 3-6
 Assembly and Preparation for Use, 2-3

B

Backhead, 4-14

C

Camshaft, 6-4
 Capabilities and Features, Centrifugal Pump Unit, 1-11
 Capacities, Equipment Data, 1-11
 Centrifugal Pump Unit
 Capabilities, 1-11
 Characteristics, 1-10
 Features, 1-11
 Principles of Operation, 1-15
 Purpose, 1-9
 Changing Engine Oil, 3-3
 Characteristics, Centrifugal Pump Unit, 1-10
 Checking Engine Oil Level, 3-2
 Checks and Services, Preventive Maintenance, Operator's, 2-2
 Unit, 4-8
 Cleaning or Replacing Air Filter Element, 3-6
 Clearance, Cylinder Head, 5-10
 Clearance, Tappet, 4-22, 5-10
 Cold, Operation in, 2-6
 Cold Start Assist, 4-16
 Common Tools and Equipment, 4-1
 Connecting Rod, 6-3
 Controls and Indicators, Operator's, T2-1
 Cover, Timing, 6-4
 Crank Assembly, 5-9
 Crankcase, 6-8
 Crankshaft, 6-7
 Cross-Reference List, Nomenclature, 1-7
 Cylinder, 5-11
 Cylinder Head and Valve Assembly, 4-22, 5-10, 6-2
 Cylinder Head Clearance, 5-10

Subject, Para

D

Data, Equipment, 1-14
 Decompression Mechanism, Adjustment of, 4-22, 5-10
 Description of Major Components, 1-12
 Destruction of Army Materiel to Prevent Enemy Use, 1-5
 Differences Between Models, 1-13
 Diffuser, 4-14
 Dimensions and Weight, 1-12
 Direct Support Maintenance
 Maintenance Procedures, 5-3
 Troubleshooting, 5-1
 Disassembly
 (See specific Items)
 Dusty areas, Operation in, 2-9

E

Engine Accessories, Equipment Data, 1-14
 Engine Assembly, 5-5
 Engine, Equipment Data, 1-14
 Equipment
 Common, 4-1
 Data, 1-14
 Improvement Recommendations, 1-3
 Inspecting, 4-5
 Preliminary Servicing and Adjustment of, 4-7
 Support, 4-2
 Unloading, 4-4
 Extreme Heat, Operation in, 2-7

F

Filter, Fuel, 4-17
 Fittings, Fuel, 4-17
 Flywheel, 5-13
 Forms, Maintenance, 1-2
 Frame Assembly, 5-14
 Fuel
 Filter, 4-17
 Injection Pump, 5-8, 6-9
 Injectors, 5-7
 Lift Pump, 4-18, 5-6
 Lines, Hoses, and Fittings, 4-17
 Tank, 4-19
 Fuel Injection Timing, Adjustment of, 6-9

G

Gears, Crank Assembly, 5-9
 General Support Maintenance Procedures, 6-1
 Governor, 6-5

Subject, Para

H

High Altitudes, Operation in, 2-8
 Housing, Pump, 4-13, 5-4
 Humid Conditions, Operation in, 2-10

I

Identification Plates, 2-5
 Impeller, 4-14
 Index, Symptom
 Direct Support Maintenance, 5-2
 Operator Maintenance, 3-5
 Unit Maintenance, 4-10
 Injection Pump, 5-8, 6-9
 Injectors, Fuel, 5-7
 Inspecting Equipment, 4-5
 Inspection
 (See Specific Items)
 Installation
 (See Specific Items)
 Instructions, Setup, 4-6
 Intermediate Term Storage, 4-26

L

Lift Pump, Fuel, 4-18, 5-6
 Limited Warranty, 1-4
 Lines, Fuel, 4-17
 Location of Major Components, 1-12
 Lubrication, 3-2

M

Maintenance Forms, Records, and Reports, 1-2
 Maintenance, Preventive,
 Operator's, 2-2
 Unit, 4-8
 Maintenance Procedures
 Direct Support, 5-3
 General Support, 6-1
 Operator, 3-4
 Unit, 4-11
 Major Components, Location and Description of, 1-12
 Muffler, 4-20

N

Nomenclature Cross-Reference List, 1-7

Subject, Para

O

Oil
 Changing Engine, 3-3
 Filler, 4-16
 Level, Checking Engine, 3-2
 Seal, 6-6
 Operating Procedure,
 Operation
 in Cold, 2-6
 in Extreme Heat, 2-7
 in High Altitude, 2-8
 in Rainy or Humid Conditions, 2-10
 in Salt Water Areas, 2-11
 in Sandy or Dusty Areas, 2-9
 Technical Principles of, 1-15
 Under Usual Conditions, 2-3
 Operator
 Controls and Indicators, T2-1
 Preventive Maintenance Checks and
 Services, T2-2
 Troubleshooting, 3-4

P

Painting, 3-1
 Piston, 5-12
 Preliminary Servicing and Adjustment of
 Equipment Setup, 4-7
 Preparation for
 Starting, 2-4
 Storage and Shipment, 1-6, 4-23
 Use, 2-3
 Preventive Maintenance Checks and Services
 Operator's, 2-2
 Unit, 4-8
 Priming Centrifugal Pump, 2-4
 Principles of Operation, 1-15
 Procedures, Maintenance
 Direct Support, 5-3
 General Support, 6-1
 Operator, 3-4
 Unit, 4-11
 Pump
 Equipment Data, 1-14
 Fuel injection, 5-8, 6-9
 Fuel Lift, 4-18, 5-6
 Pumping Rate, Adjusting, 2-4
 Purpose of Centrifugal Pump Unit, 1-9

Subject, Para

O

Quick Disconnect Coupling Halves, 4-12

R

Rainy Conditions, Operation in, 2-10

Records, Maintenance, 1-2

Removal

(See specific Items)

Repair

(See specific Items)

Repair Parts, 4-3

Reporting Equipment Improvement

Recommendations, 1-3

Reports, Maintenance, 1-2

S

Salt Water Areas, Operation in, 2-11

Sandy Areas, Operation in, 2-9

Scope, 1-1

Seal, Oil, 6-6

Setup Instructions, 4-6

Shaft Seal, 4-14

Shipment, 4-27

Short Term Storage, 4-25

Special Tools, 4-2

Speed, Adjusting, 2-4

Starting, Preparation for, 2-4

Stopping, 2-4

Storage

Administrative, 4-24

Intermediate Term, 4-26

Short Term, 4-25

Stub Shaft, 4-14

Support Equipment, 4-2

Symptom Index

Direct Support Maintenance, 5-2

Operator Maintenance, 3-5

Unit Maintenance, 4-10

Subject, Para

T

Tank, Fuel, 4-19

Tappet Clearance, Adjustment of, 4-22, 5-10

Test

(See Specific Items)

Throttle Control, 4-21

Timing

Cover, 6-4

Fuel Injection, 6-9

Tools

Common, 4-1

Special, 4-2

Troubleshooting

Direct Support, 5-1

Operator, 3-4

Unit Maintenance, 4-9

U

Unit Maintenance

Preventive Maintenance Checks and Services, 4-8

Troubleshooting, 4-9

Unloading Equipment, 4-4

V

Valves, 5-10. 6-2

W

Warning Plates, 2-5

Warranty, Limited, 1-4

Weight and Dimensions, 1-12

By Order of the Secretary of the Army:

Official:

GORDON R. SULLIVAN
General, United States Army
Chief of Staff

PATRICIA P. HICKERSON
Brigadier General, United States Army
The Adjutant General

DISTRIBUTION:

To be distributed in accordance with DA Form 12-25E, (qty rqr block no. 1336)

RECOMMENDED CHANGES TO EQUIPMENT TECHNICAL PUBLICATIONS

 <div style="border: 1px solid black; border-radius: 15px; padding: 5px; display: inline-block; margin-left: 20px;"> <p style="margin: 0;"><i>THEN...JOT DOWN THE DOPE ABOUT IT ON THIS FORM. CAREFULLY TEAR IT OUT, FOLD IT AND DROP IT IN THE MAIL.</i></p> </div>		SOMETHING WRONG WITH PUBLICATION	
		FROM: (PRINT YOUR UNIT'S COMPLETE ADDRESS)	
PUBLICATION NUMBER		DATE SENT	
PUBLICATION DATE		PUBLICATION TITLE	
BE EXACT PIN-POINT WHERE IT IS			
PAGE NO.	PARA- GRAPH	FIGURE NO.	TABLE NO.
<div style="border: 1px solid black; height: 400px; margin-top: 10px;"> <p style="text-align: center; font-weight: bold; margin-top: 10px;">IN THIS SPACE, TELL WHAT IS WRONG AND WHAT SHOULD BE DONE ABOUT IT.</p> </div>			
PRINTED NAME, GRADE OR TITLE AND TELEPHONE NUMBER			SIGN HERE

DA FORM 1 JUL 79 **2028-2**

PREVIOUS EDITIONS ARE OBSOLETE.

P.S.--IF YOUR OUTFIT WANTS TO KNOW ABOUT YOUR RECOMMENDATION MAKE A CARBON COPY OF THIS AND GIVE IT TO YOUR HEADQUARTERS.

The Metric System and Equivalents

Linear Measure

1 centimeter = 10 millimeters = .39 inch
 1 decimeter = 10 centimeters = 3.94 inches
 1 meter = 10 decimeters = 39.37 inches
 1 dekameter = 10 meters = 32.8 feet
 1 hectometer = 10 dekameters = 328.08 feet
 1 kilometer = 10 hectometers = 3,280.8 feet

Weights

1 centigram = 10 milligrams = .15 grain
 1 decigram = 10 centigrams = 1.54 grains
 1 gram = 10 decigrams = .035 ounce
 1 decagram = 10 grams = .35 ounce
 acres
 1 hectogram = 10 decagrams = 3.52 ounces
 1 kilogram = 10 hectograms = 2.2 pounds
 1 quintal = 100 kilograms = 220.46 pounds
 1 metric ton = 10 quintals = 1.1 short tons

Liquid Measure

1 centiliter = 10 milliliters = .34 fl. ounce
 1 deciliter = 10 centiliters = 3.38 fl. ounces
 1 liter = 10 deciliters = 33.81 fl. ounces
 1 dekaliter = 10 liters = 2.64 gallons
 1 hectoliter = 10 dekaliters = 26.42 gallons
 1 kiloliter = 10 hectoliters = 264.18 gallons

Square Measure

1 sq. centimeter = 100 sq. millimeters = .155 sq. inch
 1 sq. decimeter = 100 sq. centimeters = 15.5 sq. inches
 1 sq. meter (centare) = 100 sq. decimeters = 10.76 sq. feet
 1 sq. dekameter (are) = 100 sq. meters = 1,076.4 sq. feet
 1 sq. hectometer (hectare) = 100 sq. dekameters = 2.47

1 sq. kilometer = 100 sq. hectometers = .386 sq. mile

Cubic Measure

1 cu. centimeter = 1000 cu. millimeters = .06 cu. inch
 1 cu. decimeter = 1000 cu. centimeters = 61.02 cu. inches
 1 cu. meter = 1000 cu. decimeters = 35.31 cu. feet

Approximate Conversion Factors

<i>To change</i>	<i>To</i>	<i>Multiply by</i>	<i>To change</i>	<i>To</i>	<i>Multiply by</i>
inches	centimeters	2.540	ounce-inches	Newton-meters	.007062
feet	meters	.305	centimeters	inches	.394
yards	meters	.914	meters	feet	3.280
miles	kilometers	1.609	meters	yards	1.094
square inches	square centimeters	6.451	kilometers	miles	.621
square feet	square meters	.093	square centimeters	square inches	.155
square yards	square meters	.836	square meters	square feet	10.764
square miles	square kilometers	2.590	square meters	square yards	1.196
acres	square hectometers	.405	square kilometers	square miles	.386
cubic feet	cubic meters	.028	square hectometers	acres	2.471
cubic yards	cubic meters	.765	cubic meters	cubic feet	35.315
fluid ounces	milliliters	29,573	cubic meters	cubic yards	1.308
pints	liters	.473	milliliters	fluid ounces	.034
quarts	liters	.946	liters	pints	2.113
gallons	liters	3.785	liters	quarts	1.057
ounces	grams	28.349	liters	gallons	.264
pounds	kilograms	.454	grams	ounces	.035
short tons	metric tons	.907	kilograms	pounds	2.205
pound-feet	Newton-meters	1.356	metric tons	short tons	1.102
pound-inches	Newton-meters	.11296			

Temperature (Exact)

°F	Fahrenheit	5/9 (after	Celsius	°C
	temperature	subtracting 32)	temperature	

